

# gear

TECHNOLOGY®

MAR/APR  
2014

## HEAT TREATING

PPD Technology  
Eldec Ramps Up Reproducibility  
ECM Furnace Powers PM Productivity

## GRINDING

Testing the New, Advanced Grinding Wheels  
Grinding Technology Special Section



### TECHNICAL

PRESS QUENCHING  
PRECISION COMPONENTS

GEARS GRIND BY  
DRESSABLE CBN TOOLS

DOUBLE-FLANK TESTING FOR  
MANUFACTURING CONTROL  
OF GEARING

### ADDENDUM

BORN TO BLOG



# Samputensili G 250 generating and profile grinding machine

The Samputensili G 250 gear grinding machine has been especially developed for very low cycle times and for top-quality and efficient mass production of gears with outside diameters up to 250 mm and shafts with lengths up to 550 mm.

The machine is based on the dual work spindle concept, which eliminates non-productive times almost completely. By means of this feature, the loading/unloading process of a workpiece is carried out in masked time, while simultaneously the manufacturing process proceeds on another workpiece. Simple design concepts in terms of tooling and dressing technology, fast automation and amazing user friendliness are the strengths behind this innovative machine.



**SAMPUTENSILI**

**BOURN  
& KOCH**  
INC.

Phone: 847-649-1450 • [sales@star-su.com](mailto:sales@star-su.com)

5200 Prairie Stone Pkwy. • Ste. 100 • Hoffman Estates • IL 60192



The G 250 / G 450 can be easily equipped with various automation solutions



[www.star-su.com/G250geargrinding](http://www.star-su.com/G250geargrinding)



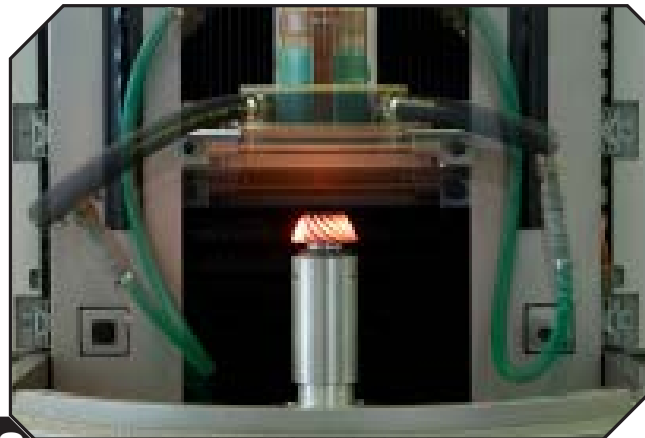

## features

- 22 Tooth Grind Wheel Testing Using a New Abrasive Grain Technology**  
Brad Foote tests out Cubitron II wheels from 3M.
- 26 The Competitive Advantage**  
Grinding/abrasives technology continues to impress in gear market.
- 38 Pulsed Plasma Diffusion**  
Wear Protection Treatment Process for Large Parts Opens New Horizons.
- 42 Hardening Technology Focuses on Dimensional Accuracy**  
Shorter model life-cycles, increasing demands continue to drive upgrades in high-tech industries like car and aircraft manufacture.

## technical

- 46 New Furnace Improves Manufacture Efficiency of PM Components**  
The concept of the multi-purpose, batch vacuum furnace is presented, the aim being to use this technology to manufacture high-load transmission gears with PM materials.
- 50 Press Quenching and Effects of Prior Thermal History on Distortion during Heat Treatment**  
How press quenching can minimize distortion of precision components during heat treatment due to effects of free or unconstrained oil quenching.
- 54 Technological Potential and Performance of Gears Ground by Dressable CBN Tools**  
This report examines the advantages of dressable CBN tools in generating gear grinding.
- 60 Practical Considerations for the Use of Double-Flank Testing for the Manufacturing Control of Gearing – Part II**  
Best use of double flank testing for the manufacturing control of spur, helical, and crossed-axis helical gearing.

# our machines are making history



*Gears for the Curiosity Rover  
were ground using the KAPP VUS 55P.*

**Gears good enough for NASA.**

**December 2008** *(date for illustrative purposes only)*

An Illinois manufacturer produces critical gears for Mars Rover "Curiosity" on their KAPP VUS 55P.

**November 2011**

Curiosity launches into space and on the sixth of August, 2012 lands successfully on Mars.

**December 2012**

Curiosity's mission is extended indefinitely.

**December 9, 2013**

Evidence reported from the Curiosity shows Gale Crater contained an ancient freshwater lake which could have been a hospitable environment for microbial life.

**February 19, 2014**

In planning Curiosity's route toward the slopes of Mount Sharp, images piqued interest in the striations on the ground formed by rows of rocks.

See photo at([www.photojournal.jpl.nasa.gov/catalog/PIA17947](http://www.photojournal.jpl.nasa.gov/catalog/PIA17947))

KAPP Technologies  
2870 Wilderness Place Boulder, CO 80301  
Phone: (303) 447-1130 Fax: (303) 447-1131

  
**KAPP NILES**



[www.kapp-niles.com](http://www.kapp-niles.com) [info-usa@kapp-niles.com](mailto:info-usa@kapp-niles.com)

Michigan | Wisconsin | China | England | India



# WE'VE CREATED A MONSTER.

Applied Process Inc. makes bigger parts, better.

Only Applied Process has the furnace – and the finesse – to produce austempered iron and steel parts that weigh in excess of 10 tons. Parts that are stronger, lighter, quieter, more wear resistant. Parts that contribute to more energy efficient operations in countless applications, from wind energy to forestry to rail transportation. Parts that increase performance while decreasing overall cost of production. We call them Monster Parts. Contact us to learn more.



# gear

TECHNOLOGY Vol. 31, No. 2

## departments

- 06 GT Extras**  
This and that from here and there in the gear world
- 08 Publisher's Page**  
Transformative Technologies
- 10 Voices**  
AGMA's Charlie Fischer Says Goodbye
- 14 Product News**  
The latest hardware, software, much more
- 70 Industry News**  
Announcements; who's up, who's down; what's new
- 76 Events/Calendar**  
The Gear Industry's dance card
- 78 Advertiser Index**  
Contact information for advertisers in this issue
- 79 Classifieds**  
Our products and services marketplace
- 80 Addendum**  
Born To Blog

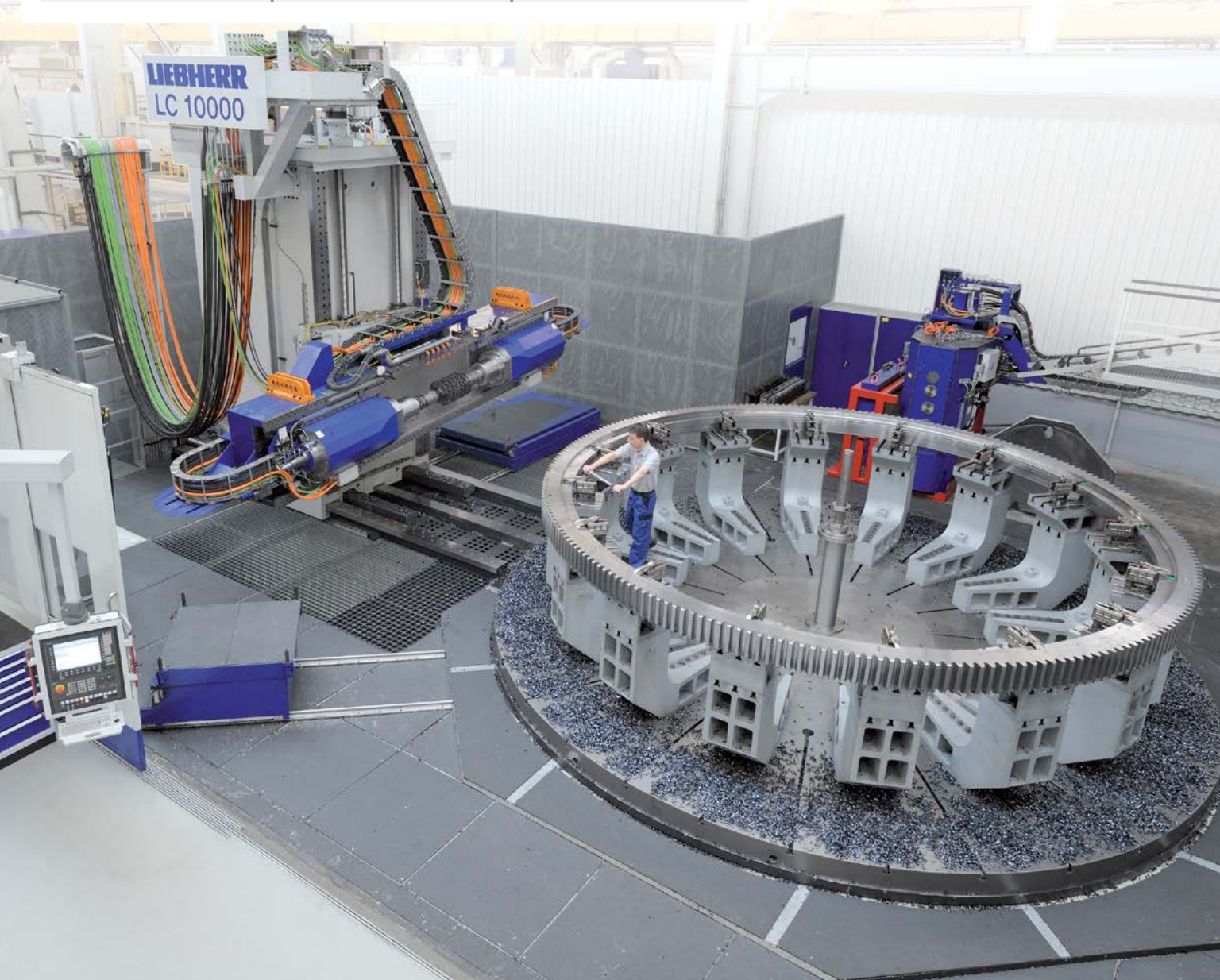

Photo courtesy of Eldec, a member of the EMAG Group

# The Bigger One.

**Gear hobbing machines from Liebherr up to 16.000 mm.**

	LC 10000	LC 16000
Module	60/100 mm	60/100 mm
Workpiece diameter	10.000 mm	16.0000 mm
Table diameter	7.000 mm	11.000 mm
Hob diameter	650 mm	650 mm
Hob Torque	10.000 Nm up to 150 1/min	10.000 Nm up to 150 1/min



Liebherr Gear Technology, Inc.  
1465 Woodland Drive  
Saline, Michigan 48176-1259  
Phone: +1 734 429 72 25  
E-mail: [info.lgt@liebherr.com](mailto:info.lgt@liebherr.com)  
[www.liebherr.com](http://www.liebherr.com)

# LIEBHERR

The Group

THE GEAR INDUSTRY'S INFORMATION SOURCE

www.geartechnology.com

GT VIDEOS

The GT website currently features a video on R&P Metrology's RPC 1000-1600 line that provides fast form roundness and profile measurements. The integrated, high accuracy rotary table allows for full four-axis generative gear inspection as well. For more information, visit [www.kapp-usa.com](http://www.kapp-usa.com).



**LinkedIn:** Celanese Corporation recently announced a range of detectable polymer technologies that can help original equipment manufacturers (OEMs) and suppliers ensure products contain components and parts that meet their material specifications. "Celanese is working with customers to help them meet their security and safety needs as they relate to protecting against counterfeiting," said Stefan Kutta, global director, Celanese Transportation industry. "These technologies are especially important today in light of several recalls due to inferior and counterfeit materials."



**Twitter:** Check out the latest links to Charles D. Schultz's Gear Technology Blog as well as product and industry news updates from companies like Koepfer, PTG Holroyd, Mitsubishi Heavy Industries, Brad Foote, Sunnen, KISSsoft and Ingersoll.

**Ask the Expert:** Do you have a question about gear design, manufacturing, heat treating, inspection or assembly? Submit your questions to our panel of experts at: [www.geartechnology.com/asktheexpert.php](http://www.geartechnology.com/asktheexpert.php)

**Gearboxfailure.com** is a resource for designers, technicians, operators, and owners of geared machinery. The site provides information on gear and bearing failure modes, how to identify the failure mode, how to prevent additional failures, and perhaps most importantly, what can be done to prevent failures from occurring in the first place. The website was created by **Rob Budny** with content contributed by Bob Errichello.



**Back to Basics:** Looking for good articles on gear fundamentals? Look no further than the Gear Technology Articles Archive. Just go to the home page and type "basics" in the search box.

Stay Connected



Follow us on Twitter  
[twitter.com/#!/Gear\\_Technology](https://twitter.com/#!/Gear_Technology)



Connect with us on LinkedIn  
[www.linkedin.com/groups/Gear-Technology-Magazine-3893880](http://www.linkedin.com/groups/Gear-Technology-Magazine-3893880)



Subscribe Online  
[www.geartechnology.com/subscribe.htm](http://www.geartechnology.com/subscribe.htm)

gear TECHNOLOGY

RANDALL PUBLICATIONS LLC  
1840 JARVIS AVENUE  
ELK GROVE VILLAGE, IL 60007

(847) 437-6604  
FAX: (847) 437-6618

EDITORIAL

**Publisher & Editor-in-Chief**  
Michael Goldstein  
[publisher@geartechnology.com](mailto:publisher@geartechnology.com)

**Associate Publisher & Managing Editor**  
Randy Stott  
[wrs@geartechnology.com](mailto:wrs@geartechnology.com)

**Senior Editor**  
Jack McGuinn  
[jmcguinn@geartechnology.com](mailto:jmcguinn@geartechnology.com)

**Senior Editor**  
Matthew Jaster  
[mjaster@geartechnology.com](mailto:mjaster@geartechnology.com)

**Editorial Consultant**  
Paul R. Goldstein

**Technical Editors**  
William (Bill) Bradley  
Robert Errichello  
Octave Labath, P.E.  
Joseph Mihelick  
Charles D. Schultz, P.E.  
Robert E. Smith

DESIGN

**Art Director**  
David Ropinski  
[dropski@geartechnology.com](mailto:dropski@geartechnology.com)

ADVERTISING

**Associate Publisher & Advertising Sales Manager**  
Dave Friedman  
[dave@geartechnology.com](mailto:dave@geartechnology.com)

**Materials Coordinator**  
Dorothy Fiandaca  
[dee@randallpublications.com](mailto:dee@randallpublications.com)

CIRCULATION

**Circulation Manager**  
Carol Tratar  
[subscribe@geartechnology.com](mailto:subscribe@geartechnology.com)

RANDALL STAFF

**President**  
Michael Goldstein

**Accounting**  
Luann Harrold





# Hunting For High Quality Gears? Forest City Gear Leads the Way

US Navy MH-60S Seahawk helicopters patrolling for mines out ahead of surface vessels use a powerful and precise Carriage Stream Tow and Recovery System (CSTRS) to quickly raise and lower mine-hunting and destruction equipment. Very high-precision gears from Forest City Gear help to ensure that the mission goes as planned. In this and many other aerospace and defense applications, Forest City Gear is helping customers meet their gear challenges – no matter how difficult to detect.

Don't let gear challenges go undetected.  
Visit [www.forestcitygear.com](http://www.forestcitygear.com).



11715 Main Street, Roscoe, IL 61073  
815-623-2168



# The Next Transformation



**Publisher & Editor-in-Chief**  
Michael Goldstein

**Every so often manufacturing is jolted out of its inertia by a transformative technology – one that fundamentally changes not only the way products are made, but also the economics of the business.**

What used to be too expensive is now affordable. What used to require multiple machines can now be accomplished with just one. The gear industry, like all manufacturing industries, has seen its share of transformations.

A hundred years ago, factories were just beginning to shift from steam-powered line shafts to individual machines powered by electric motors. Nowhere was this change more evident than in the development of the assembly line. Machine tools no longer had to be placed near a belt-driven line shaft. Instead, they could be arranged logically according to work flow. Henry Ford first started mass producing automobiles this way in 1913, but he couldn't have done it in factories powered by line shafts.

Of course, entrenched technologies are not often replaced overnight, and it wasn't until about 1950 that the line shaft was gone completely from American factories.

The development of numerical controls – and CNC machine tools – was another such transformative technology, which took place from the 50s through the 80s. But as with earlier technologies, transformation took time. It wasn't until the mid-1980s that CNC-controlled gear machines were the norm rather than the exception.

In our very first issue, published in May/June 1984, we ran an article about a transformative technology that was sure to take the industry by storm: cutting tools coated with titanium nitride. The article compared test runs between parts cut with regular, high-speed steel hobs and those cut with TiN-coated hobs. The results showed that even though the coated hobs were twice as expensive as non-coated hobs, the increased cost was justified by the increased productivity they allowed. In fact, on a cost-per-part basis, savings of as much as 40% could be achieved because the coated hobs could cut more parts per hob and at faster feeds and speeds. Today, most all types of tools are coated. Even inexpensive tools found in a hardware store have coatings.

In that same issue, we published an article about another transformative technology: CBN grinding. In that article, author Dennis Gimpert (then of American Pfauter) said, "The use of Borazon CBN form grinding represents one of the most significant process developments for soft and hard machining in the last 50 years." That article dealt with electroplated wheels,

whose productivity and process advantages at that time were enormous.

But the story of CBN and transformative technology didn't end there. In fact, I believe we may be on the cusp of yet another transformative innovation. In this issue, we feature an article about a much more recent study of grinding productivity. It talks about a new kind of CBN wheels – dressable wheels, this time – with an engineered grain structure that makes them far more productive than previous generations. Instead of abrasively rubbing off the material, the individual grains mill the metal, throwing off heat with the chips. The article is written by Jeremy Erdmann, an engineer at Brad Foote, and it deals with the Cubitron II wheels manufactured by 3M.

Ordinarily we approach the proprietary claims of individual manufacturers with a healthy measure of skepticism, so we can't just come out and endorse a product. But the fact that Brad Foote was willing to share their research certainly got our attention. Considering that many of you compete with Brad Foote, it should get your attention, too. The article can be found on page 22.

No one can say for sure whether this technology will have a transformative effect on our industry. But I've talked to people familiar with it, and it's been suggested that the kind of productivity gains and cost savings achieved by Brad Foote in this study will likely be replicated at other companies. That means fewer machines will be needed to produce the same kinds of parts. It might mean that parts that used to be cut can now be economically ground from solid. It's possible this could change the way you make gears.

If that's not transformative, I don't know what is.

## Vacuum Furnace Innovations



**aldHolcroft**  
**Vacuum Carburizing Symposium**

May 6<sup>th</sup> and 7<sup>th</sup>, 2014

Location: Ford Motor Company  
Conference & Event Center  
Dearborn, Michigan

Register online at:  
[www.ALD-Holcroft.com](http://www.ALD-Holcroft.com)

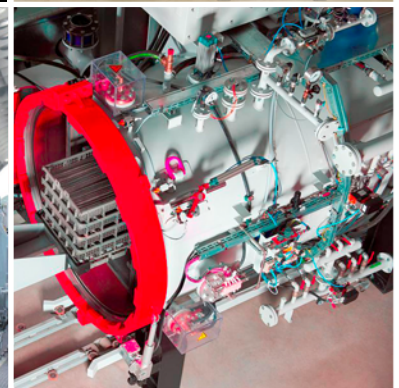
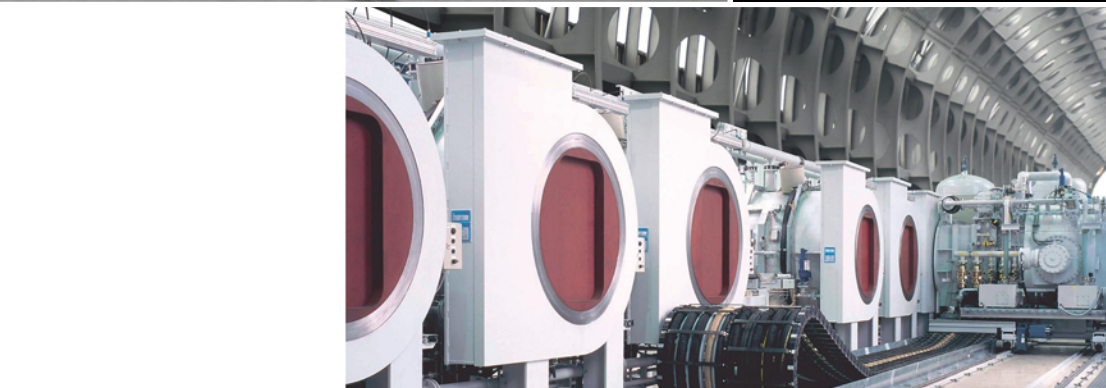

Innovative vacuum furnace technologies available for every production requirement.

**ModulTherm**<sup>®</sup>..... high volume production designed for incremental growth.

**SyncroTherm**<sup>®</sup>...high profits by synchronizing with machining centers.

**DualTherm**<sup>®</sup>..... high performance via separate heating and quenching chambers.

**MonoTherm**<sup>®</sup>..... high flexibility with a variety of processes and configurations.

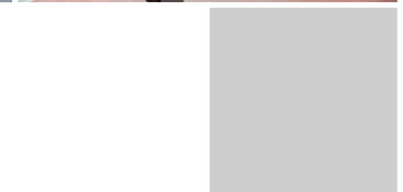

**ALD-Holcroft Vacuum Technologies**

49630 Pontiac Trail

Wixom, MI 48393-2009 USA

Ph: 248.668.4130

Fx: 248.624.3710

E-mail: [sales@ald-holcroft.com](mailto:sales@ald-holcroft.com)

[www.ALD-Holcroft.com](http://www.ALD-Holcroft.com)

# AGMA Losing One of the Good Guys

## Charlie Fischer, VP Technical Division, retiring end of April

Joe T. Franklin, Jr., AGMA President

To say that Charlie Fischer has cutting oil in his blood is not going too far! His father made a career at Philadelphia Gear and Charlie followed him after high school as a co-op student to Drexel University.

Following college, Charlie spent five years at York Division of Borg Warner Corporation, and then decided to return “home” to Philadelphia Gear in 1975.

In Charlie’s own words, “My first assignment was with the Philadelphia Mixers Division where I served as manager of engineering, overseeing projects we took on in water treatment applications.

“From here I moved to reducer engineering where I had my first opportunity to work with Bill Bradley in managing workflow and special projects related to improving efficiency. I spent a few years gaining exposure to our field service organization, working with our service technicians and solving customer issues.

“My final assignment was ‘out in the shop’ when I took on the responsibilities of heading up the assembly and production test facilities.”

He left Philadelphia Gear in 1994 when he joined Bill Bradley in AGMA’s Technical Division.

In addition to his bachelor of science in mechanical engineering from Drexel University, Charlie has a master of administrative science from Johns Hopkins University. Coupled with his broad experience in the gearing industry, Charlie was ideally suited to be part of the team at AGMA.

Promoted to vice president of the Technical Division in 2007, Charlie has used the past seven years to cement AGMA’s tech-

“Charlie has traveled countless miles and weekends, frequently with the leading experts in the industry, to do the work so important to international commerce.”

nical activities as one of the core benefits of AGMA membership. Moreover, his peers in the international committee on gearing, ISO’s TC 60 have elected him, repeatedly, to be the chairman – the Secretariat in the language of ISO – of the international group responsible for developing and maintaining the set of ISO standards for our industry.

Charlie has traveled countless miles and weekends, frequently with the leading experts in the industry, to do the work so important to international commerce.

In his final report to the board committee that oversees AGMA’s technical

activities, Charlie wrote, “When I compose the Technical Division report for each meeting of the AGMA board of directors I many times say:

‘AGMA Technical Committees continue to work diligently fulfilling their responsibility to serve as Technical Advisory Groups (TAG) to devote the time to actively research the required subject matters and prepare our delegates to defend the resultant U.S. positions.’”

I firmly believe this statement. I have had the pleasure of sitting in with these international committees when they have meetings to discuss ISO matters, and they enthusiastically execute these duties. Having to deal with what may be called ‘non-AGMA’ approaches to design and application, they learn together as they ‘study the art of gearing’ from a different approach. This all manifests itself in our presence at the table with the other international delegations where our delegates are respected because they know they are representing the U.S. position.”

Charlie is leaving a vibrant technical organization that he nurtured and led with his quiet resolve that AGMA will be second to no one and that we will always stand ready to support the best solution to the benefit of the members and the industry.

Always the professional, Charlie has built leadership in his department so it will be in good hands following his retirement. Amir Aboutaleb and Justin Sikorski are experienced



# What's in a name?

The Bard was onto something there. Since our name change from American Wera to German Machine Tools of America, GMTA has continued to bring a wide variety of high-quality German machine tools and related equipment to the North American market.

These include gear cutting and honing machines, surface grinding and deburring machines, multi-spindle lathes, multi-purpose vertical turning centers and more.

GMTA serves manufacturers of all sizes, from the specialty gear shop to the largest OEMs in the world. Standing behind every machine we sell is the GMTA team of application engineers, sales and service technicians, plus a fully stocked inventory of parts and our newly expanded demo center in the Detroit area as well as our Queretaro, Mexico office.

Today, our machines are found throughout the automotive, off-highway, heavy equipment, medical, energy and other high-production as well as specialty gear and spline markets.

Whether your product is a rose or something a lot less delicate, bring us your machining challenges. After you encounter GMTA quality, you'll call us your quality machine tool partner.



**Profilor**  
Gear Machines,  
Featuring Our  
Patented Scudding®  
Technology  
<http://bit.ly/gmtascudding>



**WMZ**  
Turning Centers  
for Big Line Shaft  
Work and More  
<http://bit.ly/wmzvids>



**Praewema**  
Honing Machines  
<http://bit.ly/prawemavids>



**Pittler**  
VTLs and Multi-  
Spindle Machines  
<http://bit.ly/pittlervids>



Scan the code and see each machine line in action!



CALL 734-973-7800 FOR MORE INFORMATION



“Charlie is leaving a vibrant technical organization that he nurtured and led with his quiet resolve that AGMA will be second to no one and that we will always stand ready to support the best solution to the benefit of the members and the industry.”

The Solution



**ALD Thermal Treatment, Inc.**

Providing the finest metallurgical services in a wide variety of markets through Vacuum Treatments and specialized gas quenches.

**LEADERS IN THE CONTROL OF DISTORTION**

**Vacuum Carburizing with High Pressure Gas Quenching  
Plasma Carburizing • Vacuum High-Temperature -  
Solution Nitriding • Vacuum Hardening • Vacuum Brazing  
Annealing • Normalizing • Cryogenic Treatments  
Measurement and Testing**

**GLOBAL SERVICE CENTERS**

- Limbach - Oberfrohna  
Germany
- Port Huron, Michigan  
USA
- Ramos Arizpe, Coahuila  
Mexico

[www.aldtt.net](http://www.aldtt.net)  
[www.ald-vt.de](http://www.ald-vt.de)

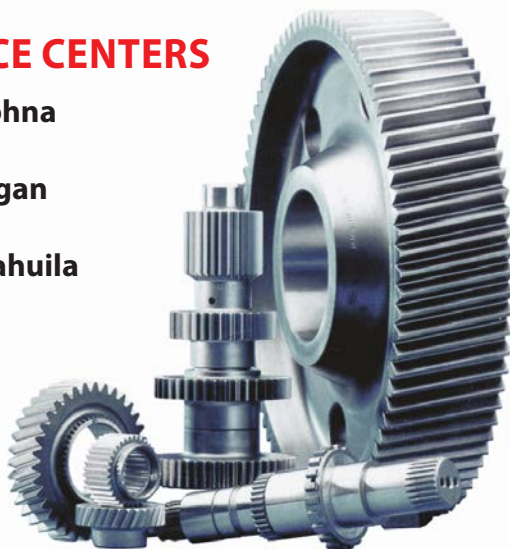

Photo: Buderus Edelstahl GmbH

Michael Pode 803-546-6686 or [mpode@aldtt.net](mailto:mpode@aldtt.net)  
Salvador Almaguer (52) 1-844-880-4701

mechanical engineers. Amir will succeed Charlie later this spring.

Many in the industry are not aware that Charlie is a passionate baseball fan, player and coach. In this upcoming season, he will have the freedom to help his grandchildren sharpen their skills on the field and enjoy their company in the stands as the Washington Nationals meet up with the Philadelphia Phillies.

*(Gear Technology would also like to extend its congratulations to Charlie on the conclusion of a brilliant career in the gear industry, and the beginning of a new chapter honing his grandchildren's skills on the base paths, at the plate, and in the field. And may they never, ever, have any "trouble with the curve."—The Editors.)*



**Joe T. Franklin, Jr.** has been AGMA President since 1994.



**CORRECTIONS:** In an exquisite example of the legendary Democratic House Speaker Tip O'Neill's adage that "All politics is local," we note that the Jan/Feb *Gear Technology* article, "Learn to Work, Work to Earn," by Senior Editor Jack McGuinn, incorrectly referred to former Washington State Governor Chris Gregoire as "he." "He," in fact, is a "she."

In the same article, a quote was incorrectly attributed to Laura Hopkins of the Washington state-based Aerospace Joint Apprenticeship Committee. On page 27, third complete paragraph, her quote should read: "**Infrastructure:** the United States' entire education system and funding structure are set up to support students pursuing the four-year college degree; this type of degree has been established as a pathway to success. **A lack of awareness:** no marketing of apprenticeship programs to employers, candidates, parents, teachers, counselors, etc. **The history of manufacturing:** outsourcing manufacturing jobs to other countries."

*Gear Technology* regrets the error.

# Gear Up Your Quality Control

Robot systems for quality control of surface treatment such as grinding and shot peening by Barkhausen Noise and X-ray stress measurements.

## RoboScan system

- automated inspection
- all surfaces with one set-up
- safe, fast and easy measuring, also on large and complicated parts
- instant feedback
- quantitative results for production control
- environmentally friendly



For residual stress testing  
by X-ray diffraction

## Xstress Robot

- reaches hard-to-reach areas
- handles complicated and large parts easily
- provides maximum flexibility and easy positioning
- is fast and precise



stresstech group

[www.stresstechgroup.com](http://www.stresstechgroup.com)



# Quick-Change Spline Rolling Racks

## OFFER NUMEROUS BENEFITS

U.S. Gear Tools Inc. of Swannanoa, NC has developed the R/C Rack System, a quick-change tooling alternative for spline rolling machines. The system saves time, simplifies logistics and has the potential to significantly increase tool life, says Mike Callesen, director of spline rolling products.

The R/C Rack System consists of two pieces: a durable carriage that is installed into a standard spline rolling machine, and a replaceable, one-use rack insert. The two pieces align with a simple cam-lock system that requires only a standard hex-wrench to turn each of five actuators.

Installing the carriage is similar to installing a standard spline rolling rack, Callesen says, except that the R/C carriage is just over half the weight of a standard rack, making it much easier to manage. But the real advantage of the R/C system, he says, is the quick changeover.

A typical tool change with old-style tooling was measured in hours, Callesen says, whereas the R/C system requires less than 10 minutes. "Once you've got the carriage set in the machine and you've run good parts, changing the insert is a piece of cake."

Another important benefit of the quick-change system is greatly simplified logistics, Callesen says. When a standard rack tool's performance diminishes, it can be restored by regrinding as many as five times. But this means the machine has to



be stopped and the tool removed, packaged up and shipped back to the tooling supplier—a time-consuming and expensive process. Also, it requires the spline manufacturer to keep at least three spares of each type on hand and manage the inventory, knowing which racks are in machines, which are in inventory and which are out for regrinding. In an automotive scale operation—possibly with hundreds of rack tools—tool inventory management is no small task.

The R/C System's inserts, however, are designed to be discarded after they reach the end of their useful life. The carriage stays in the machine and a new insert is installed in just minutes. Although Callesen still recommends that manufacturers order their spline rolling racks in sets of three, they only have to keep track of what's installed in a machine or on the shelf. They no longer have to

worry about what's being resharpened or in transit.

Also, the R/C rack inserts weigh significantly less than a full spline rolling rack, so they can generally be shipped via standard FedEx or UPS. Also overseas customers don't have to worry about how they'll get their used racks resharpened and the difficulties of shipping pieces back and forth across borders. New inserts can easily be shipped overseas.

Although the R/C Rack System was first introduced at IMTS 2012, U.S. Gear Tools has spent the past two years refining the system. They have worked very closely in conjunction with a major Tier One automotive supplier and produced more than a quarter million parts using the tools, Callesen says. This testing process has allowed U.S. Gear Tools to make sure the tool performed as expected and that its installation and use were as user-friendly as possible.

Most importantly, however, the testing and development also revealed that the new design seems to provide a significant boost in tool life over conventional tools. In fact, for this automotive application, tool life was approximately double what the manufacturer previously experienced using standard spline rolling racks.

Of course, Callesen is quick to point out that not every application should expect double the tool life. However, because of the volume of parts run, the company is confident that most applications will see appreciable tool life benefits. "The design of the tool enhances







the tool life,” Callesen says, explaining that instead of one rigid body, as in a traditional spline rolling rack, the two-piece design of the R/C system allows the tool the tiniest bit of flexibility. This flexibility is the secret to reduced tool wear, but it has absolutely no effect on the produced parts’ quality, Callesen says.

Officially, the tools went on sale in the beginning of 2014. Racks are currently available only in 24” lengths, which is the predominant size required worldwide for automotive splines. According to Callesen, the company has completed its design for 13” “thread rack” tools, and these should be available by summer, with 48” racks by the end of 2014 and 36” racks in 2015. All tools are designed to fit in a standard spline rolling machine with no modifications required.

Although the R/C Rack System tools cost more than standard rack tools, the value they offer is well worth the difference, Callesen says. When compared with traditional tools, which can be resharpened and re-used several times, the cost of the R/C tools is about 30% higher. However, this considers the direct tooling costs only, Callesen says, and ignores the indirect costs of machine downtime, tool inventory management and shipping tooling back and forth for regrinding. Considering all of that, the total cost of ownership for the R/C Rack System can be significantly less than for standard tooling. And when you add in the promise of significantly increased tool life, the value of the R/C system becomes much more readily apparent.

The tools have been well received so far, Callesen says. Many customers are

enthusiastic about the concept and are interested in learning more. U.S. Gear Tools is encouraging any spline manufacturers to give the new tooling a test on at least one of their lines. The company is confident that the results will prove themselves.

**For more information:**

U.S. Gear Tools, Inc.  
121 Lytle Cove Road  
Swannanoa, NC 28778  
(828) 686-5486  
Fax: (828) 686-5977  
sales@usgeartools.com  
www.usgeartools.com

# CUSTOM BEVEL GEAR MANUFACTURING

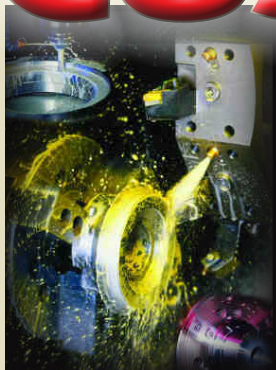

## REVERSE ENGINEERING BREAKDOWN SERVICES

- IN-HOUSE STEEL MATERIAL WAREHOUSE
- STRAIGHT BEVEL GEARS: 80" PD
- SPIRAL BEVEL GEARS: 66" PD
- FULL HEAT TREATING SERVICES
- SPURS, HELICALS, SPLINE SHAFTS
- GEARBOX REPAIR/REBUILDS
- EDM WIRE BURNING



TOLL FREE: **800 • 238 • 0651**  
inquiry@brgear.com • www.brgear.com



**Machine and Gear Corporation**

# OPEN DIE FORGINGS SEAMLESS ROLLED RINGS



**ALL PARTS ROUGH  
MACHINED  
100% UT TESTED**

**108" MAX O.D.  
6" MIN O.D.**

**UP TO 55,000 LBS  
FAST QUOTES  
48 HOURS OR LESS**

**ISO9001:2008 AS9100/2009C**

**All Metals &  
Forge Group**

**STEELFORGE.COM**



**800.600.9290  
973.276.5000**

## EMAG/Koepfer COLLABORATE ON HOBBING MACHINE

Drivers are already used to the sixth gear – and the development continues. There are plans afoot for an automatic gearbox for a 9-gear transmission system. The reason is obvious, since it allows the car to be driven at optimal speeds for longer intervals and that saves fuel. Together with the continuing pressure to optimize, high volume gear production must become faster and cheaper. The EMAG Group has demonstrated their solution: the VLC 200 H Vertical Hobbing Machine that adds a new dimension to productivity levels.

The VLC 200 H vertical hobber is the first Koepfer machine based on the new modular standards of EMAG, bearing the name of the new standard machine platform that represents a new generation of machine tools for use in a range of greatly varying applications. This “modular approach” is of great advantage when it comes to establishing a highly efficient production system for the transmission industry, as it allows for the individual processes used in the soft machining of a gear, from turning of the raw part to hobbing and deburring, to be combined with perfection and without any great outlay for automation. “The machines are easy to interlink, as they are perfectly coordinated and work at the same transfer height,” explains Jörg Lohmann of Koepfer.

The machine features high-performance drives offering top main spindle and hobbing speeds. Gears of a maximum diameter of 200 mm and module 4 can be dry-milled at greatly shortened cycle times. Removal of the hot chips generated by the process is of no concern on vertical machines, as they fall unhindered into the chip conveyor below. The typical EMAG pick-up design principle also minimizes idle times. The main spindle removes the raw-part from the conveyor belt, transfers it to the tailstock – where it is firmly supported during machining by a tailstock flange – and removes it from the machining area after



completion of the hobbing cycle. This integrated automation concept with short travels not only makes for efficient speeds, but also guarantees a high degree of machine availability.

The VLC 200 H includes a vibration-resistant polymer concrete Mineralit machine base. An optional measuring probe can be integrated into the machining area and used for either positioning tasks or the measuring of finish-machined components. “It even allows us to carry out adjustments in the machining process. In fact, the whole machine provides added value with its integrated production process quality control,” Lohmann states.

Designed on the basis of a modular platform, production planners have a choice where this automated high-efficiency package is to be integrat-



ed into a manufacturing system.. They can choose directional component flow, recirculating automation or the “chaku-chaku” principle. A processing concept, meticulously planned by EMAG experts, ensures the lowest cycle times: after turning of the raw parts on an EMAG VL 2 the gear cutting process is carried out on the VLC 200 H, with the final deburring and single-sided chamfering process following on the VLC 100 D. All these machines are designed on the “modular standard” basis from EMAG. The gearing is generated in a single cut and followed only by chamfering, in comparison to alternative production solutions that rely on a second cut after chamfering. Cycle times for the machining of gears will drop dramatically with modular EMAG solutions and Koepfer technology.

Lohmann considers the market opportunities for the VLC 200 H from Koepfer as positive: “When it comes to optimizing large-volume gear production or developing processes, we offer a highly efficient solution with integrated automation that can be configured a number of different ways. It should signal a new, interesting approach to production planners.”

**For more information:**  
 EMAG  
 Phone: (248) 477-7440  
[www.emag.com](http://www.emag.com)  
 Koepfer  
 Phone: (847) 931-4121  
[www.koepferamerica.com](http://www.koepferamerica.com)



**Leistritz**

**OVERACHIEVER**

**Leistritz keyseaters outperform all others for capability and reliability!**

By combining proven German engineering with traditional American customer support, Leistritz customers remain fully satisfied for many years throughout the long service life of these machines. So whether you're cutting a single keyway in a straight bore or a helical spline in a tapered cylinder, give us a call to discuss how our workholding and cutting tool solutions can help you improve quality.

**201 934-8262      [www.leistritzcorp.com](http://www.leistritzcorp.com)**

Leistritz Corporation 165 Chestnut Street, Allendale, NJ 07401

# McINNES ROLLED RINGS

## WHEN WEEKS ARE JUST TOO LONG ...

**WE SHIP IN AS FEW AS 5 DAYS**

By combining the latest in ring rolling technology with experienced people, McInnes delivers the best value in carbon, alloy and stainless steel rolled rings.

## Sumitomo

### RELEASES WGX WAVE MILL SERIES

Sumitomo Electric Carbide Inc.'s new WGX Wave Mill Series, used for all face milling applications, features excellent surface finish and eliminates burrs due to a unique insert chip-breaker design. The WGX body and insert combination yields improved run-out accuracy. Additional WGX benefits include lower cutting force due to its high rake angle and optimized edge treatment for long tool life with new Super ZX and Super FF coatings. In addition to the WGX Milling Series, Sumitomo Electric Carbide Inc. announces the



release of ACM200 and ACM300 insert grades for exotic and stainless steel material milling. The ACM200, which is

## Gleason

### INTRODUCES 300GMS AT CONTROL 2014

Gleason will introduce its latest Analytical Gear Inspection System, the 300GMS at Control '14, taking place May 6-9 in Stuttgart. The 300GMS enables faster complete inspection of automotive, aerospace and other smaller gears, as well as gear cutting tools and non-gear parts including a new surface finish inspection solution. Fully integrated wiring of the surface finish hardware reduces the challenges of external cabling associated with similar products. Probe integration of the surface finish function eliminates the variation seen on manual units performing a similar task.

The 300GMS is equipped with an ergonomic operator workstation and an optional Advanced Operator Interface for remote diagnostics and control - both making a significant contribution to increasing operator efficiency at every stage of the inspection process. The Advanced Operator Interface provides the operator with a number of powerful tools, including environmental monitoring to record temperature and humidity as well as video telephony, note pad and voice mail mes-

saging capability, Gleason Connect for enhanced remote diagnostic support, creation of standard work instructions, online training tools, multi-lingual communication and more.

Further highlights of the 300GMS are:

- Gear inspection for module 0.2 and higher
- 3-D-graphical tooth contact analysis
- Probe changer with up to 9 change positions
- Easy programming by means of QR code scanning
- Intuitive operator interface
- Ergonomic operating panel adjusts to allow machine operation in standing or seated position.
- Integrated drawers for probes, extensions, calibration ball and artifacts
- Small footprint - only 1.73 m<sup>2</sup>

Attendees can also experience the



**CARBON · ALLOY  
STAINLESS STEEL  
RINGS · 4" - 144" OD**

[www.McInnesRolledRings.com](http://www.McInnesRolledRings.com)

**1.800.569.1420**

a CVD grade, offers excellent wear and heat resistance and is suitable for hardened material milling. The ACM300, which is a PVD grade, features highly balanced wear and fracture resistance and is the first recommendation for stainless steel milling. The progressive WGX Series further demonstrates Sumitomo Electric Carbide Inc.'s commitment to cutting-edge innovation in face milling applications.

**For more information:**  
Sumitomo Electric Carbide  
Phone: (800) 950-5202  
[www.sumicarbide.com](http://www.sumicarbide.com)

1000GMS Analytical Gear Inspection System as well – it will be presented at the Gleason booth (#3308 in Hall 3).

**For more information:**  
Gleason Corporation  
Phone: (585) 473-1000  
[www.gleason.com](http://www.gleason.com)



 WINTERTHUR
  WENDT
  SlipNaxos

Now part of 3M





# What will Your Reaction be?

## Introducing 3M™ Cubitron™ II Conventional Wheels for Gear Grinding

### Re-inventing the art & science of gear grinding

New Cubitron II wheels will take your grinding process to the next level of productivity. This 3M technology will dramatically increase throughput, improve productivity and minimize burn and burnishing.

- Higher removal rate
- Runs cool – virtually eliminates burning & burnishing
- Lasts up to 2 to 4× longer – with less dressing – than wheels containing traditional grain
- Available in Single Rib, Threaded/Worm and Spiral Bevel/Curvic configurations



**What's the secret?**

3M™ Cubitron™ II Gear Grinding Wheels are powered by precision-shaped grain, pioneered by 3M. As the uniform triangular grains wear, they break to form sharp points that “slice” through metal – to stay cooler, cut faster and last longer! Learn more at: [www.3M.com/cubitron2/GearGrinding](http://www.3M.com/cubitron2/GearGrinding)

**Superior Strength Expected Precision**

© 3M 2013. 3M and Cubitron are trademarks of 3M Company. Used under license by 3M subsidiaries and affiliates.



# PTG/Holroyd

## PRODUCES LARGE HELICAL PROFILE MILLING MACHINE

Holroyd manufactured one of the world's biggest high precision screw rotors for a major gas compression project in the Far East using its EX Series model. The process necessitated the manufacture of 816 mm diameter rotors as matched pairs, with a finished dimensional tolerance between the male and female forms maintained to tens of

microns across the intermeshing profile surfaces.

On behalf of a major Chinese compressor manufacturer, the company then produced one of the largest helical profile milling machines ever constructed. The machine in question, an 8EX model, is now in daily use, dry pre-machining



<p><b>CHALLENGE:</b> Improving cycle times, throughput and tool life</p>		
	<p><b>SOLUTION:</b> <b>DURATOMIC® INSERT GRADES</b></p> <ul style="list-style-type: none"> <li>• Manipulation of oxygen and aluminum atoms creates an optimal insert coating</li> <li>• Optimal balance of hardness and toughness allows more aggressive cutting data</li> <li>• Minimization of friction and heat to improve surface quality and insert wear</li> </ul>	

then finishing outside screw compressors for the gas processing industry.

What made this particular project so remarkable, however, was the sheer scale of the technology involved. Weighing in at an incredible eight tonnes plus, each of the stainless steel rotors produced required a machine capable of handling diameters of up to 850 mm and material lengths of up to 4.5 m. Not surprisingly, the project presented a number of major challenges for which Holroyd called on its well-known and considerable ability to develop ingenious engineering solutions

### High efficiency production

Always aiming to raise the benchmark for precision, Holroyd appreciates only too well that a key aspect of high efficiency rotor production is the accurate pre-machining of the rotor profile form. Whilst generally referred to as the 'rough milling operation', this process is actually the precise milling of the rotor profile in preparation for subsequent finishing. This is because any inaccuracies in this process can easily affect the accuracy of the finishing stage.



## OPTIMIZE YOUR TURNING AT THE ATOMIC LEVEL

SECO TOOLS.COM/US



SCAN FOR A FREE DURATOMIC SAMPLE INSERT!



# Ajax Tocco

## OFFERS ADVANCEMENTS IN GEAR HARDENING

### Speed in reserve

The product of various evolutions since the models of the 1970s, today's Holroyd EX Series milling machines are designed with the ability to maximize the high surface speeds demanded by the very latest cutting technologies. Indeed, understanding that efficiency, performance and longevity are key in machine development and build, all Holroyd EX Series models are built with considerable levels of speed in reserve to embrace further developments in cutting tools.

Surface speeds in excess of 200 m/min, for example, are often used when cutting the rotor profile forms in a single pass to leave only the allowance of 0.3 mm stock for the finishing operation.

### For more information:

PTG Holroyd  
Phone: +(44) 1706 507 990  
[www.holroyd.com](http://www.holroyd.com)

Recognizing the demand for greater equipment simplicity has motivated Ajax Tocco Magnethermic Corp. to develop and refine a customer-driven, innovative system based on the use of a specifically precise, selected-single programmed frequency. This frequency is used to produce the required diametrical pitch, gear tooth profile-hardened pattern.

### For more information:

Ajax Tocco Magnethermic Corp.  
Phone: (800) 547-1527  
[www.ajaxtocco.com](http://www.ajaxtocco.com)



Advanced fully flexible gear heat treat system with integrated computational capability to make stronger gears.

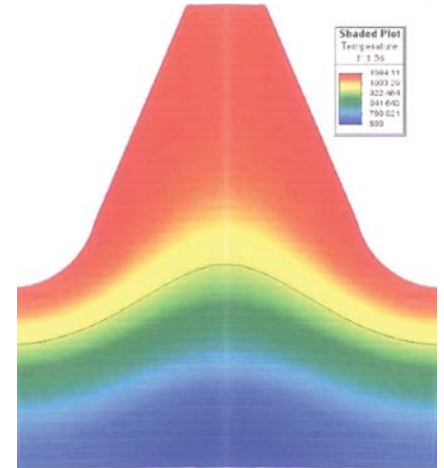

Computer-modeled hardness profile.

## All The Gear Cutting Tools You Will Ever Need Are Right Here

### DTR is one of the world's largest producers.

#### DTR. Your best choice for high quality gear cutting tools.

DTR is a world class supplier of the finest high performance long-life gear manufacturing tools, for small and large gear cutting applications. Established in 1976, we are one of the world's largest producers of cutting tools, shipping to over 20 countries.

DTR offers a full line of gear cutting tools including:

- Hobs
- Carbide Hobs
- Shaper Cutters
- Milling Cutters
- Chamfering and Deburring Tools
- Broaches
- Master Gears

We can produce virtually any tool you need for auto, aerospace, wind, mining, construction and other industrial gears.

Every tool is precision-made utilizing high speed steel, premium powder metal or carbide and the latest in coatings, to achieve superior cutting and long life. DTR uses top of the line equipment including Reischauer CNC grinders and Klingelnberg CNC sharpeners and inspection equipment.

Learn more about our outstanding quality tools at [www.dragon.co.kr](http://www.dragon.co.kr).

Call us at 847-375-8892 for your local sales representative or  
Email [alex@dragon.co.kr](mailto:alex@dragon.co.kr) for a quotation.



# DTR

PERFECTION MOVES US

(formerly Dragon Precision Tools)

[WWW.DRAGON.CO.KR](http://WWW.DRAGON.CO.KR)

**DTR has sales territories available. Call for more information.**

**U.S. Office Location (Chicago)**  
Email inquiries to: [alex@dragon.co.kr](mailto:alex@dragon.co.kr)

1865A Hicks Road, Rolling Meadows, IL 60008

PHONE: 847-375-8892 Fax: 224-220-1311

Headquarters

36B-11L, Namdong Industrial Complex, Namdong-Gu, Incheon, Korea

PHONE: +82.32.814.1540

FAX: +82.32.814.5381

# Brad Foote and 3M

## Collaborate on Testing of Ground Parts

Jeremy Erdmann, Brad Foote Gearing

### Efficiency improvements, cost savings and better quality production are goals that any gearing company strives to achieve.

However, it can be difficult and time-consuming to find routes to meet these goals. Nonetheless, the potential benefits are enticing enough to justify investment in testing and redesigning materials and technologies in order to ensure a competitive advantage. This article will describe the testing carried out by Brad Foote Gearing in its search for a better abrasive wheel.

Brad Foote Gearing makes fully integrated precision gearing solutions, from design and engineering to specialty weldment and testing. With a long background in tight-tolerance gearing for wind turbines, the company is now expanding into broader energy and infrastructure markets. The company applies precision down to the fraction of a millimeter or micrometer to meet the tightest tolerances and the highest industry standards, which of course places significant demands on its abrasive materials.

### The Challenge for a New Wheel

Brad Foote recently conducted testing on abrasive wheels for the production of low speed pinions and bull gears used in wind turbines. These two jobs were selected due to the fact that they are on the high end of difficulty for the parts that are ground at Brad Foote. The high quality standards for these parts, as well as the materials used and modifications required, mean that these jobs are difficult to mass-produce quickly. In the competitive gearing market, any innovation that reduces cycle time has the potential to help increase profitability,

so this testing was performed with an eye toward uncovering opportunities for improved efficiency. Furthermore, any potential to improve the quality of the gear being produced was of course welcome as a way to demonstrate added value to the customer.

The parts being produced in the test were made of CrNiMo material, which cracks very easily in grinding, similarly to glass. Additionally, the specifications for the parts are extremely tight. Therefore the tooling and grinding strategies used for these parts are critical. The existing two wheels that had been in longtime use for the pinion and bull gear will be hereafter referred to as wheel A (a finer wheel used for both parts) and wheel B (a coarse wheel that was used for the bull gear prior to finishing with wheel A).

Although wheels A and B were part of well established procedures, Brad Foote conducted testing to attempt to find a wheel solution that could achieve a number of different goals, chiefly reducing cycle time and tool usage. Achieving these goals had a strong potential to create cost savings, even if the abrasive cost per part was higher than the existing wheels.

### Alternative Abrasive Technology

The challenger product that Brad Foote selected for full scale testing was a 3M Cubitron II Vitrified Wheel, which the manufacturer claimed could achieve significant improvements in productivity and tool usage. The wheel is capable of these improvements due in part to the grain technology it uses, which is quite different from any other conventional grinding wheel. Most conventional



Brad Foote converted its processes for the pinion and bull gear to utilize the Cubitron II wheel. The company has also begun implementation of the wheels for additional grinding applications in the mining industry.

bonded wheels currently on the market use grains that are irregular in shape, which “plow” through metal, resulting in friction. This friction generates heat, dulls the grain, and adds time to the cutting process. However, the Cubitron II wheels utilize technology from 3M’s microreplication platform to create “precision-shaped grains.” The resulting grains are tiny, triangle-shaped structures that continuously fracture during grinding to form new edges and points, allowing the material to self-sharpen. Instead of the plowing action seen with conventional abrasives, precision-shaped grains “slice” through metal. Not only does this reduce damage and discoloration of parts due to heat, but it also allows the wheels to cut cleaner and fast-

**Table 1 Low Speed Pinion Grinding Results**

Low Speed Pinion Grinding Results		
	Wheel A	3M Cubitron II Wheel
RH Cycle Time	107 minutes	46 minutes
LH Cycle Time	107 minutes	46 minutes
Total Cycle Time Per Complete Piece	3.34 hours	1.32 hours
G ratio		~2X wheel A

**Table 2 Comparison for Equal-Sized Batches of Ground Parts (Low Speed Pinion)**

Comparison For Equal-Sized Batches of Ground Parts*: Low Speed Pinion		
	Wheel A	3M Cubitron II Wheel
Abrasive Cost	\$7,574	\$10,787
Machine Cycle Time	297 hr, 36 min	128 hr, 8 min
Machine Cost (@ \$50/hr)*	\$14,880	\$6,407
Total Cost of Operation	\$22,454	\$17,194
Savings		\$5,260 per batch

\*For comparison purposes only. Actual machining costs proprietary to Brad Foote.



er than conventional wheels, and to last longer.

### Low Speed Pinion Production

The existing production process for the low speed pinion utilized wheel A for tooth grinding, with the wheel able to perform both roughing in and finishing, although it required frequent dressing. Each hand required a separate program for grinding, with the cycle time per hand running at 107 minutes. To produce a complete part using wheel A, total cycle time was just over 3.5 hours. Wheel A also had a lifespan of just 2.5 parts per wheel. The long cycle time for this part made it a challenge to meet the customer's high production demands, and also monopolized a machine, which was dedicated to this job alone. In addition to reducing cycle time and tool usage, testing for this part was designed to find a product that could maximize machine capacity. When the Cubitron II wheel was used for the same task, it reduced the cycle time per one complete part to 1.5 hours. In addition, the wheel ground 5 complete parts before needing a tool change, and improved the flank finish and general appearance at nital etch inspection. It was evident that the Cubitron II wheel was able to remove more stock with less dressing, without glazing the wheel.

As seen in the comparison tables, while the total abrasive cost of the Cubitron II wheels was higher, the machine cycle time required to produce the same number of parts was less than half that of wheel A, reducing the total cost of the operation by almost 25 percent. Because



The photo shown here is not the bull gear being discussed, but is included as an example of what happens to this type of material with the incorrect tooling or grinding strategy (all photos courtesy of Brad Foote).

fewer wheels are needed to produce the same number of parts, the Cubitron II wheels also save storage space. The additional machine capacity enabled by the Cubitron II wheels allows the company to pursue additional business instead of having the machine tied up year-round solely for production of the pinion.

### Bull Gear Production

Brad Foote's existing process to grind a bull gear, a double helical gear, involves two separate processes for each hand, with two different grades of wheels

required. Wheel B, the roughing wheel, was not able to meet the flank finish requirement, and thus wheel A was used for finishing. Wheel A was not suitable for roughing, as its grit was too fine and would burn the material. The roughing cycle per hand averaged 8 hours, with two wheels used in the roughing stage. Wheel A was then interchanged to achieve the desired flank finish, for which it barely met the required standard. Two wheels were also required in the finishing cycle, a very long-running cycle with many challenges.

## Now is the Time!

### BRING YOUR HEAT TREATING IN-HOUSE!



Low Pressure Vacuum Carburizing • Neutral Hardening • Oil Quenching  
20 bar High Pressure Gas Quenching • Carbonitriding • Annealing

#### ECM Technologies' systems can offer:

- No Flames
- Precise Quality Control
- Automated Loading/Unloading
- 35ft x 30ft Floorspace
- Just in Time Heat Treating



**ECM USA Inc**  
VACUUM FURNACES

GLOBAL MANUFACTURER OF INDUSTRIAL FURNACES

8920 58th Place, Ste 100 Kenosha, WI 53144-7822 T. 262.605.4810 WWW.ECM-USA.COM

The photo shown is not the bull gear being discussed here, but is included as an example of what happens to this type of material with the incorrect tooling or grinding strategy. As previously stated, the material has the potential to crack like glass. Due to the limitations of wheels A and B, which affect how quickly and aggressively the wheels can grind, the bull gears are ground very slowly with extreme caution. The challenges in grinding the bull gear were therefore even greater than for the pinion. Like the pinion testing, the goals for a new wheel for the bull gear included reduction of cycle time and tool usage, but with the additional goals of eliminating the two-wheel process and improving the quality of the gear.

Testing showed that the Cubitron II wheel met all of these goals. One single Cubitron II wheel grinds both the rough and finish processes, versus the four wheels required by the old method. The wheel dresses less often, avoiding wear on the tool so that both hands can be ground with one wheel. Cycle time is reduced by more than 50 percent, to 5.66 hours per hand. (Testing is ongoing, with additional cycle time improvements possible.) While with wheels B and A, there was a struggle to keep the flank finish under the maximum allowable, with the Cubitron II wheel the flank finish after grind falls .30 microns below maximum. These capabilities allow operators to rapidly produce parts to quality specifications.

The comparison tables for the bull gear present an even more compelling case than those for the pinion. Because only one Cubitron II wheel is needed to perform the same work of four of the old wheels, an abrasive cost savings of more than \$8,500 can be realized per batch of parts. In addition to this, the cycle time is again less than half that of the original process. Adding the abrasive and machine savings, the total cost of this

**Table 3 Bull Gear Grinding**

Bull Gear Grinding			
	Wheel B- Rough Grind	Wheel A- Finish Grind	3M Cubitron II Wheel
RH Cycle Time	8 hours	4 hours	5.66 hours
LH Cycle Time	8 hours	4 hours	5.66 hours
Total Cycle Time for Completion	24 hours		11.3 hours*

operation was reduced by nearly 50 percent with additional time savings possible with more optimization.

### Persuasive Results

This testing was performed in late 2012 and early 2013, and based on its conclusive results, Brad Foote converted its processes for the pinion and bull gear to utilize the Cubitron II wheel. The company has also begun implementation of the wheels for additional grinding applications in the mining industry.

Several other wheels were also considered in the early stages of this trial, but none of the products was able to match the performance of the Cubitron II wheel. In particular, the Cubitron II wheels' ability to achieve the surface finish on the flanks was particularly hard for other wheels to match. Furthermore, none of the parts burned or cracked during testing with the Cubitron II wheel, even when testing conditions were set to push the wheel to its maximum. This was a notable achievement for working with such a challenging material.

### The Value of Free Machine Time

This testing is an excellent demonstration of the capabilities of the Cubitron II product line. When an abrasive can slice through metal instead of just plowing through it, it works faster and longer, and with less heat generation. The cumulative benefits of these attributes are shown in the tables of this article—dramatic reductions in cycle times, and more parts created with fewer wheels.

The value of the machine time regained from use of the Cubitron II wheels is perhaps one of the most

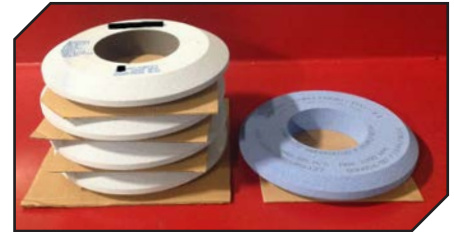

Cubitron II wheels utilize technology from 3M's microreplication platform to create "precision-shaped grains." The resulting grains are tiny, triangle-shaped structures that continuously fracture during grinding to form new edges and points allowing the material to self-sharpen. Instead of the plowing action seen with conventional abrasives, precision-shaped grains "slice" through metal.

important aspects to consider, and also one that is hard to precisely calculate. But it is clear that when machine time is freed up, the company can take in new projects for which it simply did not have the capacity before. Projected over the course of many months, the advantages of Cubitron II wheels are not only lower total wheel costs, but dramatically increased production capacity. In addition, the company gains the ability to turn out parts more quickly and reliably, helping ensure that products consistently reach the customer on time. With benefits in efficiency, cost and part quality, Cubitron II wheels have conclusively proven their worth at Brad Foote. ⚙️

#### For more information:

Brad Foote Gear Works, Inc.  
Phone: (708) 298-1100  
info@bwen.com  
www.bwen.com

3M

Phone: (888) 364-3577  
www.3M.com/PrecisionGTA

Special thanks to Dan Carleton of Gear Gear, Inc. and Chad Wesner of 3M for helping bring this article to fruition.

**Table 4 Comparison for Equal-Sized Batches of Ground Parts (Bull Gear)**

Comparison For Equal-Sized Batches of Ground Parts*: Bull Gear			
	Wheel B	Wheel A	3M Cubitron II Wheel
Total Cost of Wheels	\$14,702	\$14,702	\$20,940
Machine Cycle Time	825 hours		337 hours
Abrasive Cost	\$29,504		\$20,940
Machining Cost (@\$50/hr)*	\$41,250		\$16,850
Total Cost of Operation	\$70,754		\$37,790
Total Saving			\$32,964

\*For comparison purposes only. Actual machining costs proprietary to Brad Foote.

**Table 5 11-Month Results for Low Speed Pinions and Bull Gears**

11-Month Results for Low Speed Pinions and Bull Gears		
	Wheels A and B	3M Cubitron II Wheel
Total Operating Hours**	1122.6	465.13
Total Cost of Wheels	\$36,978	\$31,727
Machine Costs	\$56,130	\$23,257
Total Costs	\$93,108	\$54,984
Total Savings		\$38,124 / 41% cost reduction

\*\*Does not include re-work or 1st piece article.

# Choose the best solutions



## Diverse, Flexible Production

When it comes to diverse components that are integrated into critical functions, you need the flexibility to be able to carburize, nitride and harden a wide range of parts with different materials, case depths, hardenability and geometries. Add to that the challenge of meeting strict industry specifications and you'll need a partner like Ipsen to help you find the solutions you need to deliver high-quality, repeatable results.

### Batch Furnaces

When your heat treating production mix has several recipes, Ipsen Atmosphere Batch furnaces deliver flexibility with production lines that run different processes simultaneously and can expand as production demands increase. Ipsen equipment delivers flexibility and lower costs with efficient burners and optional automation.

### Vacuum Furnaces

Ipsen delivers proven vacuum technology that allows you to achieve maximum flexibility by executing processes like brazing for coolers and heat exchangers, hardening or annealing for automotive parts and tools, as well as many other processes, depending on your specific needs.



Batch

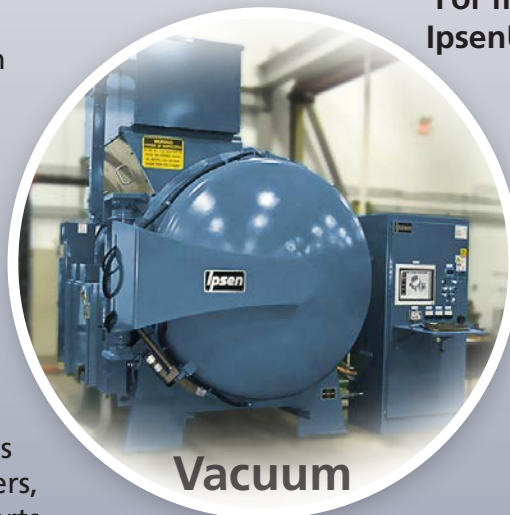

Vacuum

For more information, visit [IpsenUSA.com/Atmosphere](http://IpsenUSA.com/Atmosphere).



Hard Work Wins



# In Search of a Competitive Advantage

## Grinding/Abrasive Technology Continues to Impress in 2014

Matthew Jaster, Senior Editor

The grinding/abrasives market is rapidly changing, thanks to new technology, more flexibility and an attempt to lower customer costs. Productivity is at an all-time high in this market, and it's only going to improve with further R&D. By the time IMTS 2014 rolls around this September, the gear market will have lots of new toys and gadgets to offer potential customers. If you haven't upgraded any grinding/abrasives equipment in the last five years, now might be a good time to consider the investment.

## Kapp Technologies

**BILL MILLER DISCUSSES  
LATEST GRINDING  
TECHNOLOGY**

Kapp and Niles offer the industry's widest range of machines and tools for profile and threaded wheel gear grinding, says Bill Miller, vice president sales at Kapp Technologies.

In the heavy duty truck transmission market, the focus is on flexibility. Automation with robotics is becoming more prevalent, according to Miller. "As non-grinding time becomes a more significant proportion of total production time, automatic loading is essential for high-output. Our KX 260 and KX 500 machines are designed so that customers can easily integrate robots on site.

The automotive industry requires all grinding machines be able to grind a variety of gears, to reach maximum efficiency and flexibility. Our compact KX 100 Dynamic offers this efficiency with its automated work arbor change and semi-automatic wheel change. A full change-over, including inspection, is accomplished in only 20 minutes."

Customers that rebuild gearboxes continue to look for design improvements in order to differentiate their service, according to Miller. "Integrated software simulates modifications, and high-speed measurement verifies the grindability of a part prior to grinding. These are two improvements which significantly add to the quality of the rebuild. Tools are also available for super-finishing as a post process in the grinding machine."

The aerospace market is also benefiting, as they replace 30-year-old Kapp grinders with the latest models. For expanded options, CBN tooling compatibility is offered not only on Kapp V-Series machines but also on Niles ZE Series and ZP Series machines. And modern software shortens the learning curve dramatically for all grinding processes, while still enabling customers to program special grinding cycles."

He adds that all market segments continue the trend towards dressable tools when economics are favorable. "Kapp diamond dressing tools allow our customers to count on us for turn-key support. We're extending the lifetime of the tools and lowering the costs for our customers. This is key to our business," Miller says.

Finally, "multifunctional machines" continue to gain attention. These machines are designed either as a single unit, where datum surfaces and diameters are finished in sequence with the gear teeth in one clamping, or as multiple machines tightly integrated to function as one. The incentive to invest in this technology, however, is still tempered by uncertainty in the market.

Miller believes that increased competition in this area helps. "Multifunctional machines are a higher price and in order to prove to the market their multiple

benefits, technical expertise on both ends is critical," Miller says. "We're going to gain some traction in this area during the next growth period as more and more customers begin to see the advantages of these machines. A lot of our competition is following us on these developments, which can only make the market more attractive."

### For more information:

Kapp Technologies  
Phone: (303) 447-1130  
[www.kapp-niles.com](http://www.kapp-niles.com)

## Drake Manufacturing

**INTRODUCES JOB SHOP  
THREAD, WORM AND GEAR  
MACHINE**

Drake Manufacturing Services Co. recently introduced its latest machine solution designed for a multifunctional machining platform. With its internal thread, external thread, and profile gear grinding capability, Drake's Ultimate Job Shop Thread, Worm & Gear Machine (Model GS:JS) offers the versatility required in a job shop environment for half the cost of three separate machines. This universal, 4-axis CNC machine was developed for grinding internal and external threads, as well as profile grinding gears.

Features include a cast polymer base for thermal stability and dynamic stiffness, linear motors on linear ways for high acceleration and contouring capability, fewer mechanical parts, and low-maintenance operation, a high accuracy workhead—0.002° index accuracy, power helix for quick changeovers and ±90° helix/lead angles and Drake Part Smart menus for changeovers in as little





as 15 minutes with simple entry of new part parameters.

Stig Mowatt-Larssen, Drake's R&D Manager, stated, "This machine is ideal for production of small batches in a cost-efficient manner. Our product development team fine-tuned this machine with a gear & thread job shop in Japan, grinding everything from fine pitch pinions against a shoulder with a 25 mm diameter wheel to ball nuts to lead screws. The JIS Class 0 pinions measured great, and the customer appreciated no wheel run-out into the adjacent bearing journal."

"We worked with this high-quality prototype shop to upgrade our *Gear Smart* software to include simpler form modification menus and the ability to

more simply 'dial-in' the tooth form for a first-good-part that is so important for job shops" said Rick Sanders, systems engineering manager and chief software architect. The 390 mm diameter by 1 meter length machine was delivered to a short-run custom gage and prototype job shop in central Japan.

**For more information:**  
Drake Manufacturing Services Co.  
Phone: (330) 847-7291  
[www.drakemfg.com](http://www.drakemfg.com)

## Norton Abrasives

### NEW ABRASIVES BOND TECHNOLOGY BENEFITS GEAR GRINDING

Norton Abrasives has developed and launched Norton Vitrium3, the next generation of bonded abrasives products, engineered for maximum performance and cost savings in precision grinding. An entirely new abrasives platform, Norton Vitrium3 features a patent-pend-

ing bond technology developed by the Saint-Gobain Abrasives R&D team. This bond features an exclusive chemistry that promotes excellent grain adhesion, resulting in improved product versatility across a wide range of applications. Substantial performance improvements with Norton Vitrium3 are now attainable in all Norton abrasive grains, from proprietary Norton Quantum ceramic alumina to conventional aluminum oxide.

Norton Vitrium3 has three major features and benefits over standard vitrified bonds including a stronger bond construction to meet higher wheel speeds, an improved holding power utilizing less bond-to-abrasive ratio for an improved cut rate and significantly less burn, while reducing power consumption and grinding forces on the part. An increased porosity eliminates burn or other part damage.

Products including gears, camshafts, crankshafts and bearings are using materials that are more difficult to grind. The primary products for all of these precision grinding applications are vitrified grinding wheels and segments.



## ZRIME — Pioneering China Gear Manufacturing



Located in Zhengzhou, the capital of Henan Province, Zhengzhou Research Institute of Mechanical Engineering (ZRIME) has undergone 50 years of development. The company was restructured from a former research institute under the Ministry of Mechanical Industry into a large-scale science & technology enterprise administrated by the central government of China. As one of the first high-tech enterprises in Henan Province and the pilot enterprise of scientific and technological renovation in Henan Province, ZRIME are authorized to grant the doctor's degree in field of machinery design and the master's degree in machinery design and engineering mechanics.

ZRIME are also authorized by the State for the planning and the administration of gear transmission technology in mechanical industry of China.

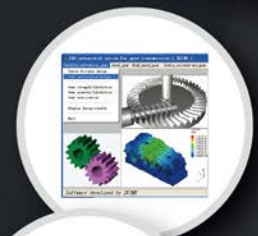

**ZHENGZHOU RESEARCH INSTITUTE OF MECHANICAL ENGINEERING**

NO. 81 Songshan South Road, Zhengzhou, Henan 450052, China | Tel: 86 371-67710564 | Fax: 86 371-67710565 | Web: [www.zrime.com.cn](http://www.zrime.com.cn) | Email: [cheny@zrime.com.cn](mailto:cheny@zrime.com.cn)

A substantial amount of work has been done over the last 20 years on the cutting tool portion of the wheel, the abrasive grain. In 1990, Norton Abrasives introduced the first ceramic alumina abrasive, Norton SG. This new grain offered much higher performance in all areas of precision grinding as a result of a combination of the hardness of each ceramic alumina grain and the new science of "controlled micro-fracturing."

The vitrified or glass bond is the material that holds or bonds the abrasive grain together. The heavier the bond-to-grain ratio, the harder or stronger the wheel is and the more pressure needed to break down the bond to release new abrasive grain for cutting. The correct balancing of bond-to-grain ratio is necessary to provide enough holding power for the grain to perform the required cutting steps and starts without burning or damaging the work. For some materials or in some wide contact areas, artificial media is introduced into the matrix, which burns out during firing to leave a large, porous structure, which promotes

better coolant flow, retards the dulling of the grain and reduces burn.

This bond platform features an exclusive chemistry that delivers an entirely new grain adhesion science, resulting in improved product versatility across a wide range of precision grinding applications. The chemistry of holding the abrasive grain in the bond matrix for the precise amount of time is referred to as "grain adhesion science." Norton Vitrium3 is a new product formulation that substantially increases the module of elasticity or strength of the bond. This allows for less bonding material to be used to provide the same holding power on the individual abrasive grain.

In a large gear grinding application example for the wind energy market, Vitrium3 enabled a 67% reduction in dress comp. per part and a 13% reduction in total cycle time. The Vitrium3 wheel was single rib, 16 x 2 x 5 inches

(Baseline Spec: 60-G, Vitrium3 Specs: 3TGP60-G12VS3GB). The application was "Involute Pinion - Grind Teeth" with a steel part diameter of 8 inches and width of 19 inches, 60 HRc. The wheel speed was 1,443 rpm with stock removal at .04 inch and a 32 Ra surface finish.

#### For more information:

Norton Abrasives  
Phil Plainte, Senior Applications Engineer  
Phone: (508) 795-2833

[www.nortonindustrial.com/vitrium3](http://www.nortonindustrial.com/vitrium3)



## Thermal Processing Equipment for the Production of Bearings and Gears.

### Designed, Manufactured and Serviced by AFC-Holcroft.

- One of the most diverse product lines in the heat treat equipment industry: **Pusher Furnaces, Continuous Belt Furnaces, Rotary Hearth Furnaces, Universal Batch Quench (UBQ) Furnaces** – all designed and optimized for the production of bearings and gears
- Customized solutions with full turnkey service including load/unload automation, press quenching, etc.
- Worldwide infrastructure in North America, Europe and Asia
- More than 90 years of experience and thousands of projects realized worldwide



For further information please visit [www.afc-holcroft.com](http://www.afc-holcroft.com)

AFC-Holcroft USA · Wixom, Michigan | AFC-Holcroft Europe · Boncourt, Switzerland | AFC-Holcroft Asia · Shanghai, China

# MTB-Burri

## OFFERS FLEXIBLE AND COST EFFECTIVE GRINDING SOLUTIONS

MTB-Burri is offering manufacturers flexible and cost effective solutions in the grinding world that were only available in Europe until now. With MTB's engineering expertise, service support, and operational facilities, Burri is being launched and embraced with high interest. Installations of Burri grinders and dressing machines have been in operation for 20 years and are in many prominent, well-known companies throughout the world. Industries include automotive, machine tools, agriculture and other market sectors. Only as recently as 2013 has the first grinder been installed in the United States.

Burri CNC Continuous Generating Gear Grinders are built on the mechanical basis of the Reishauer type AZO/AZA/RZ 301/RZ 361/RZ 362/RZS platforms. Operators, engineers and companies accustomed to Reishauer grinders will find that the Burri grinders utilize adaptable clamping mechanisms so all tooling can be interchanged, reducing additional investment in tooling. The machine is equipped with a B&R controls system, high performance Ethernet network, compact I/O system, modular drives with energy recovery system, digital absolute precise encoders, and CNC control on all axes, and an attached electrical cabinet.

The grinding support has hardened linear guides, a synchronous motor which is directly connected to the grinding spindle and adjustable from 0 to 3,500 rpm (corresponds to a cutting speed of 63 m/sec). It's also equipped with a completely new profiling slide with ball bearing spindle, linear ball guides and linear measuring system that allows the profiling cycle to occur in both directions (forwards/backwards). The wheel guard has integrated meshing probes and a transmitter for balancing the head. Its short cone grinding spindle is engineered for installation of the balancing head for a fully-automatic balancing system for handling grinding wheels with dimensions of 350 x 104 x 160 mm.

All original Reishauer components that were liable to become maintenance problems are eliminated, such as electric clutches, indexing plunger, lead screw of the dressing slide with all change gears, and other.

### For more information:

MTB-Burri  
Phone: (815) 636-7502  
[www.machinetoolbuilders.com](http://www.machinetoolbuilders.com)



WHEN YOU NEED IT RIGHT  
THE FIRST TIME

# The Broach MASTERS

Much  
More  
Than Just a  
Broach  
Company!

## & Universal Gear

The quality and precision of our Broaches, Shaper Cutters and Gears have won customers world-wide - from the smallest gear shop to NASA and the Mars Rover.

- Broach & Shaper Cutter manufacturing & repair
- Gear & Spline—prototype to production
- Master Gears & Gages
- Small & fine pitch

**Precision. Performance. Perfection.**  
The First time and every time.

**The Broach Masters, Inc.**

"DEDICATED TO EXCELLENCE"

1605 Industrial Drive  
Auburn, CA 95603  
Phone: (530) 885-1939  
Fax: (530) 885-8157  
Web: [www.broachmasters.com](http://www.broachmasters.com)  
Email: [info@broachmasters.com](mailto:info@broachmasters.com)

**U.G.C.**  
MADE IN U.S.A.



# Liebherr

## SINGLE TABLE GEAR GRINDING MACHINE DELIVERS QUALITY

With a one-table design and a new-design grinding head, the Liebherr LGG 180 and LGG 280 machines greatly reduce grinding times for twist-free profile and generating grinding. The machines are designed to deliver consistent high large-scale production quality in automotive applications, including conical gearing. According to a Liebherr spokesman, "With this series of space-saving machines, vehicle manufacturers can develop a complete production line, in which all gearing components for a passenger vehicle transmission can be ground: planetary and sun gears, bore-type gears, as well as drive and pinion shafts with lengths up to 500 mm."

The advantage to the one-table solution is higher quality throughout the entire production. There is one clamping fixture, one geometry. Every machined part is manufactured under the same conditions for the highest reproducibility. The one-table approach provides the

statistical capability and reliability in continuously producing controlled  $\mu$ -range finish quality for gear noise optimization.

The new grinding head allows for rotation speeds up to 10,000 rpm and has spindle power of 35 kW. With this performance data, the head enables high cutting speeds and high feed rates. The new grinding machine can exploit the considerable potential of the innovative 3M abrasive Cubitron II. Changing the grinding arbor with HSK-C 100 tool holder is a fast and simple process. Also available is a second grinding head for featuring a small worm diameter for collision-critical parts.

The machine will enable undulations to be applied specifically to gear wheel flanks for noise optimization purposes for the first time. The ability to produce sub- $\mu$  range waviness cost-effectively gives designers a whole new range of optimization options. The touch screen

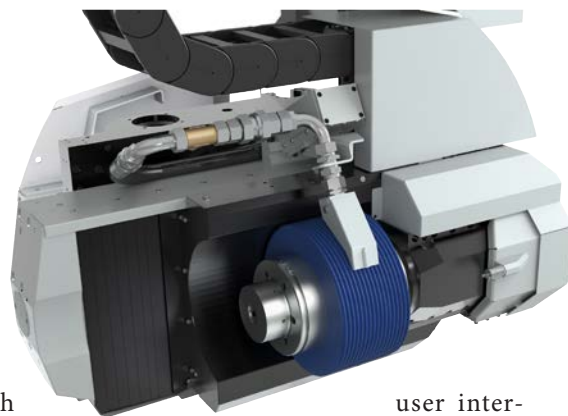

user interface on the machine control permits easier, intuitive programming and machine operation and incorporates an integrated webcam. The control also can incorporate substantial additional documentation, such as fixture layouts and tool mounting instructions. The LGG machines are easily coupled with Liebherr automation solutions to create a fully automated production line for the highest quality gears in the least possible cycle times.

**For more information:**  
Liebherr Gear Technology, Inc.  
Phone: (734) 429-7225  
[www.liebherr.com](http://www.liebherr.com)

**Quality Gears...**

**Start with Quality Heat Treating!**

1-855-WE-HEAT-IT  
[www.solaratm.com](http://www.solaratm.com)

**SOLAR**  
ATMOSPHERES  
Vacuum Heat Treat Services



# Gleason Corporation

## SINGLE-SOURCE CUSTOM OPTIONS

Manufacturers of large gears expect modern gear-grinding machines to be able to produce excellent quality gears with considerably increased productivity and maximum process reliability at low cost. With its Titan 1200G gear grinding machine, Gleason-Pfauter has succeeded in satisfying these discerning requirements. The Titan 1200G can be individually configured to suit customer requirements and provides maximum productivity, flexibility and quality. Use of a fully-automatic tool changer facilitates entirely new machining strategies for grinding gears. The Titan includes a fully automatic tool changer, combined profile grinding, Opti-Grind and Power-Grind. The possible machining strategies allow productivity and flexibility for the user, taking into account not just the desired workpiece geometry, but also many other production and customer-specific boundary conditions.

Gleason recently announced the availability of a profile grinding option for its 300TWG Threaded Wheel Grinding Machine. Gleason's 300TWG is for customers who demand the high levels of productivity and flexibility provided by the threaded wheel grinding process, especially for medium to large size batch production. Now with the addition of a profile grinding option, the machine is also well-suited to smaller batch and high-precision production, making the 300TWG a truly universal gear grinder. The combination of the two processes covers the full range of production possibilities. Dr. Antoine Tuerich, director of product management - Profile and Threaded Wheel Grinding Solutions remarked, "With the integration of the new dressable profile grinding option, the already successful 300TWG Threaded Wheel Grinding Machine becomes more flexible than ever before, allowing the configuration of this machine to meet nearly any customer requirement. Depending on the customer's application, it may be used either as a threaded wheel or a profile grinding machine. User-friendly, graphically supported software simplifies the process, yet offers a high degree of sophistication and control."

### For more information:

Gleason Corporation  
Phone: (585) 473-1000  
[www.gleason.com](http://www.gleason.com)



## When You Have Only One Shot At Rotary Accuracy, Make It Count!



### Manual Low-Profile Circle Divider

Basic A.G. Davis CIRCLE DIVIDER™ features standard indexing of 360° or 720° positions. Round or square face plates with diameters up to 48". Patented fail-safe lock. Automatic systems available. 36/72 position economy model also available.

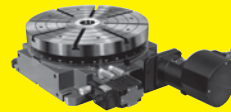

### Ball Bearing Rotary Table

Angular contact, double row, preloaded ball bearings provide the optimum combination of accuracy, stiffness and low friction. Digital readout-radial runout to .000005".

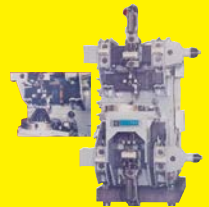

### 5-Axis CMM

The 5-axes computer controlled special coordinate measuring machine has four air bearing precision linear motions and an air bearing rotary table. Laser measurement incorporating a unique path layout and environmental monitoring compensates for pitch and sag. Air bearing electronic probes contact the part contour. The total system accuracy is .0000050" within the envelope of travel.



### Two-Axis Servo/Rate Rotary System

Vertical 16" faceplate dia. table and horizontal 9" dia. air bearing table with integral motor drive and precision encoder.



### Astro Guidance Test Platform

References the north star three axis (Ultradex) index system. System accuracy 0.3 arc second band, PC based control, IEEE-488 interface.



### Air Bearing Rotary Table

The ultimate precision rotary table for CMM and other high accuracy applications. Radial runout to .000001 T.I.R. Can be used vertical or horizontal. Servo or standard motor drives.



### Automatic NC Precision Trunnion

4th & 5th axis machining capabilities. Three available grades of angular accuracy on both the rotational axis and tilting axis: ± 3 arc second, ± 2 arc second, and ± 0.25 arc second. Face plate platens from 350 mm to 630 mm. Larger sizes available upon request.



### 50 inch Precision Centrifuge

- Accelerometer Testing
- Constant "G" within (+/- 0.01%)
- 32 Slipping Channels
- 0.2 to 200 "G" Range
- Outputs for rate sensing
- IEEE - 488 Interface

**Inspection  
Radial Milling  
Calibration  
Calibration Services  
Index Position  
Contouring  
Circle Division  
4th - & 5th Axis  
Machining**



Contact us direct or visit our website  
**A.G. Davis - AA Gage**

Telephone: 586-977-9000 • Fax: 586-977-9190  
[www.agdavis.com](http://www.agdavis.com) e-mail: [agdavis@agdavis.com](mailto:agdavis@agdavis.com)

# Mitsubishi Heavy Industries

## OFFERS NEW PROCESSING METHOD FOR GRINDING INTERNAL, EXTERNAL AND SHOULDER TYPE GEARS

In the field of gears used for automotive transmissions and reducers in robots, after-heat treatment gear grinding has been spreading for the achievement of gear units with lower noise and higher precision. Along with the further reduction of the weight and cost of gear units, there is a growing number of workpieces that are difficult to machine such as ring gears (internal gears) in planetary gear systems and multi-shoulder type gears widely used in the automatic transmissions of vehicles and power transfer systems for hybrid cars. One of the methods for grinding internal gears is a form grinding method that grinds tooth spaces one by one. However, this method is rarely used in volume production because its machining efficiency is low. Therefore MHI developed the ZI20A, the world's first internal gear grinder for use in volume production, in 2009. Through continuous process develop-

ment with Japanese automotive manufacturers and grinding wheel producers, MHI can now offer a robust and affordable process for grinding internal ring gears.

For grinding external gears, on the other hand, a continuous generation gear grinding method using a multi-threaded grinding wheel has been widely used. MHI also has the ZE series that employs such a method. This method achieves highly efficient grinding by meshing a multi-threaded grinding wheel with a diameter of 200 to 300 mm and the gear to be ground. When this method is used for grinding multi-shoulder type gears or shaft-integrated pinion gears

(workpieces that turn-up at the edges), however, it is difficult to grind the tooth flank because the grinding wheel and the workpiece interfere with each other.

Thus MHI has equipped the ZI20A gear grinder with an hourglass-shaped grinding wheel and a fixture for grind-

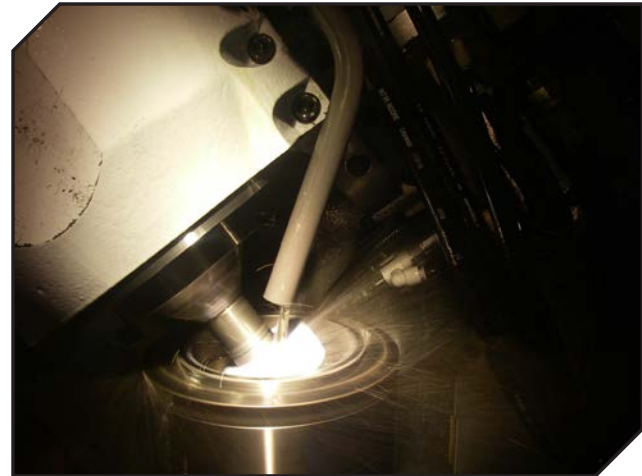

### HANS-JÜRGEN GEIGER

Maschinen-Vertrieb GmbH

Metzingen/Stuttgart



**High quality used machine tools  
from Germany since 1968.**

Please visit our showrooms:  
7000 sqm display area with more than  
600 machines in best condition.

**HANS-JÜRGEN GEIGER**

Maschinen-Vertrieb GmbH

James-Watt-Straße 12

D-72555 Metzingen (Germany)

Phone +49 (0) 7123 / 18040

Fax +49 (0) 7123 / 18384

E-Mail: [geiger@geiger-germany.com](mailto:geiger@geiger-germany.com)

[www.geiger-germany.com](http://www.geiger-germany.com)

MIKRON  
DMG | DISKUS  
TBT | HELLER  
ELB | NAGEL  
SCHAUDT  
KEHREN  
KARSTENS  
MIKROSA  
INDEX | ZEISS  
BOEHRINGER  
GILDEMEISTER  
SCHÜTTE  
AGIE | SCHULER

Gear cutting  
machines:

LORENZ | HURTH  
PFAUTER | KAPP  
KOEPPER | NILES  
LIEBHERR  
REISHAUER  
LINDNER  
KLINGELBERG  
GLEASON  
WMW



ing external gears to develop a method allowing for the highly precise and efficient grinding of gears that were difficult to machine in the past. The main technologies used in the developed machine to allow for grinding external gears are a grinding wheel spindle that achieves rigid and stable rotation at low to high rotation speeds, the employment of an hourglass-shaped threaded grinding wheel and highly precise on-machine dressing and a control method for the amount of tooth flank modification (crowning) by adding compensation to the grinding motion.

Because a cylindrical grinding wheel interferes with the workpiece at the both edges of the grinding wheel due to its crossed-axis angle, a barrel-shaped threaded grinding wheel is required. A barrel-shaped threaded grinding wheel and the internal gear to be ground (workpiece) mesh with each other performing a generating motion to grind the internal gear. For grinding external gears, on the other hand, an hourglass-shaped threaded grinding wheel and the external gear to be ground (workpiece) mesh with each other.

For both internal and external gear grinding, higher grinding speed is required to improve grindability (i.e., lower grinding resistance and higher grinding ratio). The grinding speed is dependent on synchronous rotation between the grinding wheel spindle and the workpiece and the sliding of the tooth flank due to crossed-axis angle. Therefore sliding velocity (grinding speed) can be enhanced by increasing the rotation speed of the grinding wheel spindle and the workpiece and enlarging the crossed-axis angle. The developed grinding method is achieved due to the development of a grinding wheel spindle and a work-holding table spindle that can synchronously rotate at higher speeds, the design of an hourglass-shaped threaded grinding wheel dependent on a crossed-axis angle and the creation of its dressing method.

MHI has developed a method allowing for the highly precise and efficient grinding of external gears that were dif-

ficult to machine using conventional gear grinding methods with a threaded grinding wheel. This was achieved simply by attaching a grinding wheel and a fixture for external gear grinding to the ZI20A gear grinder, which was initially exclusive to internal gear grinding. MHI has enabled the machine to perform external gear grinding and enhanced its

versatility. The company will continually meet the needs of customers by working on the further improvement of accuracy and efficiency of machining, as well as tool life.

**For more information:**  
 Mitsubishi Heavy Industries America  
 Phone: (248) 669-6136  
[www.mitsubishigearcenter.com](http://www.mitsubishigearcenter.com)



## PEOPLE AND TECHNOLOGY MAKE THE DIFFERENCE

At Presrite, our experience, innovation and expertise ensure that you get the best net and near-net forgings. Our new Tech Center has state-of-the-art design, engineering technology and die-making capabilities.

- Dedicated state-of-the-art facility
- Presses up to 6,000 tons of capacity
- .008-.060 stock allowance on gear blanks
- ISO 9001:2008
- TS 16949:2009



[www.presrite.com](http://www.presrite.com) • 216-441-5990



# Star SU

## ESTABLISHED CONCEPTS HIGHLIGHT THE G 250

Star SU LLC offers the Samputensili G 250 generating grinding machine based on the established concepts of the best-selling Samputensili S 250/400 G machine, which have been further enhanced and improved. The result is an innovative, compact and extremely flexible gear grinding machine. The Samputensili G 250 has been especially developed for very low cycle times



and for top-quality and efficient mass production of gears with outside diameters up to 250 mm and shafts with lengths up to 550 mm. Moreover, the machine features dual work spindles that eliminate non-productive times almost completely. Particular attention has been paid to the state-of-the-art solutions that allow a fast tool change, e.g. from hobbing to grinding, guaranteeing process versatility. The machine can equally use form and worm grinding wheels, both in ceramic and in CBN electroplated. Simple design concepts in terms of tooling and dressing technology, fast automation and amazing user-friendliness are the strengths behind this unique machine.

### For more information:

Star SU  
Phone: (847) 649-1450  
[www.star-su.com](http://www.star-su.com)

# Reishauer

## RZ 260 HANDLES HIGHER LOADS AND FORCES

Reishauer AG based the RZ 260 on its successful RZ 150 series. The machine was developed for the high demands of the continuous generating gear grinding process. The machine boasts the Reishauer Generating Module, LNS Low Noise Shifting technology and Twist Control Grinding technology that customers have come to expect from Reishauer machines. The RZ 260 can be fitted with one or two work spindles. A single spindle is efficient if investment and tooling costs must be minimized. When grinding gears with space limitations or small lot sizes the customer may consider the changeable profile grinding spindle that enables the use



# EXCEL GEAR, INC.

## GEARS 1"–60" - AGMA 15

The **EXCEL** promise;

*We'll excel where others fall short.*

- Complete gear design, manufacturing and reverse engineering services
- Gear hobbing & grinding from 1"–60" (To AGMA 15)
- Internal gear grinding from 10"–60"
- Gear shaping to 36" diameter (9" face width)
- Wind turbine gear boxes, high speed spindles, gimbal heads and gear boxes
- Competitive prices and quality gear design and manufacturing with delivery commitments you can count on!

**A TOTAL SERVICE COMPANY**  
ISO9001-2008 APPROVED

**Introducing Excel-Lent Gear Design Software**  
providing accurate gear design and analysis that can get anyone up and running fast—[www.excel-lentsoftware.com](http://www.excel-lentsoftware.com)

# 815-623-3414

[quotations@ExcelGear.com](mailto:quotations@ExcelGear.com)

[www.ExcelGear.com](http://www.ExcelGear.com)



## Performance Proven Heat Processing Equipment for the Gear Industry

Tip-Up Furnaces | Internal Quench Furnaces  
Tempers | Washers | Carbottom Furnaces  
Box Furnaces | Pusher Furnaces | Pit Furnaces

- Manufacturing thermal processing solutions for over 50 years.
- Extensive range of standard products for stand-alone or total systems.
- Engineered solutions to meet specific process or configuration needs.
- Reliable products focused on ease of operation and maintenance.
- Commitment is to satisfy companies by providing Performance.
- Proven Heat Processing Equipment Incorporating the Latest Product Enhancements.
- Contact BeaverMatic to find out more about how we can help your company succeed.

Get heat treating solutions through our simplified yet sophisticated furnace designs.



**IQF  
Furnace**



**Temper  
Furnace**



**Washer**



**Carbottom  
Furnace**



**Box  
Furnace**



**Tip-Up  
Furnace  
with a  
20,000 lb load**

of a small plated or dressable wheel to grind gears with the discontinuous profile method. Both versions of the RZ260 can be equipped with a fixed or CNC-controlled axis for swiveling the dressing tool. This offers a significant increase in flexibility.

**For more information:**

Reishauer Corporation  
Phone: (847) 888-3828  
[www.reishauer-us.com](http://www.reishauer-us.com)

## Klingelberg

### VIPER SERIES FOCUSES ON EFFICIENCY AND PRODUCTIVITY

The adaptable gear grinding machine Viper 500 is designed for component diameters up to 500 mm and is optimally suited for both the smallest and the largest batch sizes. It is available in three different configurations, depending on individual requirements: profile grinding, small grinding wheels and

multiple-wheel technology (Viper 500 K), and generation grinding (Viper 500 W). Particularly for users with frequent product changes, the flexible machine concept ensures an even more dynamic and efficient production process. The Viper 500 W configuration allows both profile grinding and continuous generation grinding on the same machine – with minimal retooling time. To change the grinding technology, just swap out the grinding wheel, the grinding wheel flank and the dressing wheel. On all three variants, the optional internal gear



grinding arm allows retooling from external to internal gearing in less than 15 minutes.

At the same time, the special machine axis arrangement provides the basis for maximum precision, continuous quality, and tremendous flexibility. Thanks to its innovative design, the machine is powerful, easy to clean, and extremely energy efficient. And last but not least, the proprietary GearPro software guarantees routine operation for the attendant, even when the applications are complex.

**For more information:**

Klingelberg  
Phone: (734) 470-6278  
[www.klingelberg.com](http://www.klingelberg.com)

# RESIDUAL STRESS MEASUREMENT

LABORATORY & FIELD SERVICES • XRD SYSTEMS • RETAINED AUSTENITE

## Reduce costs and improve quality.

Residual stress plays such a critical role in the fatigue life, cracking and distortion of components, that its characterization is more important than ever. In today's tough economic times, X-ray Diffraction (XRD) residual stress measurement can both improve quality and help lower component cost by reducing scrap rates, shortening design cycles and ensuring full component life.



Our comprehensive line of XRD residual stress measurement systems and full service laboratories have the accuracy, speed, technology and knowledge to keep your product perfect right from the start.

**LABORATORY SERVICES**



**FIELD SERVICES**



**PORTABLE XRD SYSTEMS**



**LABORATORY XRD SYSTEMS**

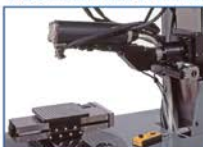

[www.protoxrd.com](http://www.protoxrd.com)

1 (800) 965-8378

USA  
Proto Manufacturing Inc  
313-965-2900  
[xrldlab@protoxrd.com](mailto:xrldlab@protoxrd.com)

Canada  
Proto Manufacturing Ltd  
519-737-6330  
[proto@protoxrd.com](mailto:proto@protoxrd.com)

Japan  
Proto Manufacturing KK  
047-402-2703  
[info@protoxrd.jp](mailto:info@protoxrd.jp)



**MITSUBISHI**  
HEAVY INDUSTRIES AMERICA, INC.

Our Technologies, Your Tomorrow

# A Crowning Achievement In Shaping Technology



ST40A  
**STseries**

**Programmable Lead Guide with NC Relieving Delivers  
Greater Accuracy, Productivity and Ease of Operation.**

Mitsubishi Heavy Industries is pleased to introduce the new and enhanced programmable lead guide ST40A machine. Built for precision and performance like the original, the new ST40A is now also equipped with a CNC relieving mechanism, capable of producing gears with taper up to 0.3 degrees and crowning up to 0.070mm. For more information visit [www.mitsubishigearcenter.com](http://www.mitsubishigearcenter.com) or contact sales at 248-669-6136.

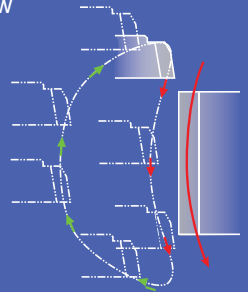

# PPD

## Wear Protection Treatment Process for Large Parts Opens New Horizons



Figure 1 Large steel gears for the shipping industry weighing multiple tons and 8.8 feet (3 meters) in diameter have been wear-protected with the PPD solution (all photos courtesy Oerlikon Balzers).

Environmentally friendly, highly efficient and lasting a product's lifetime. With characteristics like this, Pulsed-Plasma Diffusion (PPD) technology from Oerlikon Balzers has established itself as an industry standard for the treatment of large automotive press tooling. Now the technology specialists are targeting new applications with this advanced process, offering an alternative to traditional hard-chrome processes. Large rollers for the steel industry and large gears for shipping and wind turbines are being processed.

In the PPD vessel, parts with a weight of up to 40 metric tons and dimensions of 32.2 feet × 8.9 feet × 5 feet can be treated. With a single PPD treatment the large automotive tooling dies are wear-protected and ready for five years model life production. Typical production volumes of 300,000 vehicles per year and a total production volume of 1.5–3 million parts can be stamped with a single PPD treatment of the tool; and with the tools always ready for production, productivity improvements of up to 25%, compared to the traditional used and constantly re-treated hard chrome tools, are typically found. The PPD technology also protects the tools without the use of dangerous chemicals such as hexavalent chrome.

With advantages like this, leading automotive companies and suppliers worldwide rely on PPD technology to safeguard their production. But this is just the start. "We want to open new markets for PPD technology and introduce the benefits of this technology to other industrial branches," says Phil Read, head of sales and business development, PPD, at Oerlikon Balzers Schopfheim, Germany—worldwide development center for the technology.

The target is, however, not automotive tooling, but, for example, large steel rollers for the transportation of painted steel coils through the production lines. These rollers, typically made of 4140 material, are responsible for removing the entry burrs on the steel coils before painting. These rollers are subject to deep wear tracks from the burrs—leading to quality issues on the finished painted coil. For this reason the rollers are traditionally hard-chrome-plated. "PPD-treated roll-



Figure 2 In the PPD chamber, parts with a weight of up to 40 metric tons and dimensions of 32.2 ft. × 8.9 ft. × 5 ft. can be processed.



ers last 10 times longer and the results have been confirmed with customer trials,” Read ensures.

In addition, large industrial gears for shipping wind turbines (32CrMo12) weighing multiple tons and spanning meters in diameter are being PPD-treated. Here the PPD technology shows its advantages over traditional case-hardening technologies such as flame and induction hardening. Through the improved surface quality, reduced part deformation and, therefore, minimal rework of the part after treatment, the PPD technology allows a reduction in the production steps for steel, cast steel and cast iron parts.

PPD technology is available worldwide. PPD machines are installed in Germany (Schopfheim), United States (Pell City, Alabama), Korea (Busan), China (Suzhou) and Japan (Shizuoka).

### PPD: Diffusion process with integrated cleaning cycle

Powered by a combination of nitrogen, hydrogen and electricity, PPD technology uses a diffusion process to build a wear-protective, compound layer and a reinforcing, diffused hardness increase in the material. The process occurs in the PPD vacuum chamber—among the largest of its type in the world. Unlike typical nitriding, the required bake-out or cleaning of the parts before treatment—which typically oxidizes the part surface—is unnecessary, as this is integrated into the PPD process cycle. The part cleaning cycle is performed in the PPD chamber under vacuum. This process integration ensures safe temperature control of the part at all times and produces an extremely smooth surface treatment. After PPD treatment the surface can easily be re-worked, welded or heat-popped, providing a maintenance-friendly solution. ⚙️

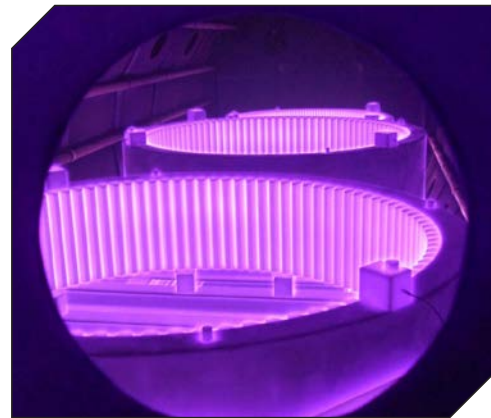

**Figure 3** A PPD treatment in a pulsed-plasma atmosphere not only protects large automotive forming tools, but also large, heavy-industrial parts such as these gears for wind turbines.

#### For more information:

Roman Gaida  
Business Development Manager, PPD  
Oerlikon Balzers Coating Germany GmbH  
Hohe-Flum-Straße 22  
DE - 79650 Schopfheim  
Germany  
Phone: +49 7622 399949  
Fax: +49 7622 399947  
Mobil: +49 171 8999844



## METROLOGY CENTER

### NEXT DIMENSION® Gear Measurement Systems



ND300



ND165

- Analytical Gear Inspection
  - DOB/DOP Gages
  - Double Flank Testers
  - Single Flank Testers
  - Gear Burnishing Machines
  - Gear Deburring Machines
  - Master Gears
  - Spline Gauges
  - REPOWERED Gear Inspection Machines
  - Metrology Services
- Contract Inspection

Windows7 64 Bit OS • Minimal Operator Training Required • Intuitive User Friendly Software

6555 St Route 202 Tipp City, OH 45371 PH: 937-667-4451 Fax: 937-667-9322 [www.peco-us.com](http://www.peco-us.com) Email: [info@peco-us.com](mailto:info@peco-us.com)

# Gleason

THE  
**TOTAL**

**POWER  
SKIVING™**

**THERE'S AN  
EXCITING  
NEW  
PROCESS  
IN YOUR  
FUTURE**

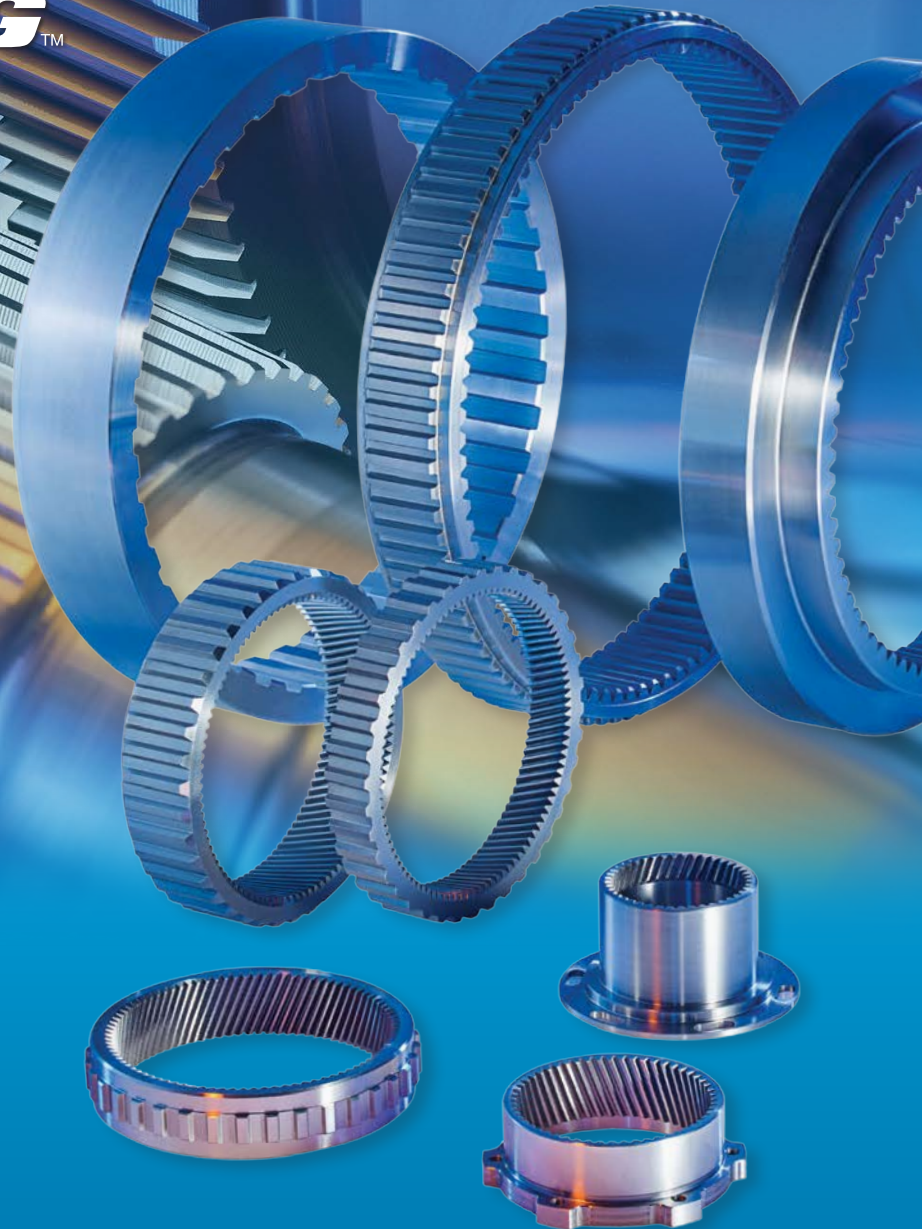

**SOLUTIONS FOR CYLINDRICAL AND BEVEL GEARS OF ALL TYPES AND**

✓ Bevel Gear Solutions,  
Up to 2,500 mm

✓ Cylindrical Gear Solutions,  
Up to 10,000 mm

✓ Metrology Solutions,  
All Types of Gears,  
Gear Tools

✓ Cutting Tools and  
Workholding Solutions,  
All Processes

**For worldwide sales locations and additional information, visit:**

# GEAR SOLUTIONS™

PROVIDER

Gleason Power Skiving marks the beginning of a new era – where new machines, tooling and process simulation software converge to finally make Power Skiving practical, affordable and highly productive. It's a complete system that's much faster than shaping, and delivers many competitive advantages compared to broaching, including increased flexibility.

Gleason Power Skiving.  
The solution has finally arrived.  
Learn more at:  
[www.gleason.com/PS](http://www.gleason.com/PS).



Production of cylindrical gears up to 600 mm in diameter, swing diameters to 750 mm and modules up to 6 mm.



Gleason's Power Skiving solution includes highly productive cutting tools and workholding solutions.



Innovative cutter measuring system helps ensure first-part size accuracy after every cutter change.

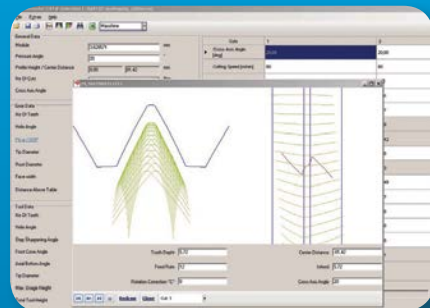

Before the first chip is removed, Gleason's process and application specialists know the results using powerful simulation software.

## SIZES, EVERY PROCESS

✓ Global Services, 250 Factory-Trained Personnel in 30 Countries Worldwide



THE  
**TOTAL GEAR**  
**SOLUTIONS**  
PROVIDER

**Gleason**

# Hardening Technology Focuses on Dimensional Accuracy

## Introduction

Shorter model life-cycles, increasing demands on quality, and technological innovations continue to drive developments in high-tech industries such as car or aircraft manufacture. Hardening best shows the effect this has on the production environment. As many key components go through this process at one stage, it is a process that not only has to be highly accurate, but also guarantee consistently high component quality. Committed to the requirement of reproducibility, the specialist at Eldec's modular hardening machines offer exceptional precision and economic processes.

Reproducibility is an indisputable requirement in car production, since an automobile as a product is reliant on the unvarying component quality of the drive shaft. The indispensable hardening process, where the components' microstructures undergo a change to considerably improve stability, must guarantee constant reproducibility.

**Where quality matters.** Eldec experts are very well aware of the fact that the interaction between key components such as inductors, generators and coolant systems, and a multitude of other components including indexing tables, spindle drive and control systems, is of utmost importance. Over the last three decades German-based Eldec has further developed their hardening technology, and in February of 2013 the company became a part of the EMAG Group. Precision and the integrity of the production process are important

to Eldec experts, as Dr. Christian Krause, head of application technology, explains. "We are frequently contacted by companies that require their components to be of exceptional quality, and we can guarantee that with our system technology."

At the center of it is the modular induction (MIND) hardening machine, offered in various sizes of MIND, MIND-M and MIND-S. Using modular technology, the machines are configured to suit individual workpiece dimensions, hardness profiles and production requirements. The modular system ensures that only well proven components are used, increasing machine stability and guaranteeing that the technology can be offered at an advantageous price-performance ratio.

"The engineering of the machine is, of course, greatly influenced by the workpieces to be hardened," explains Krause. "Requirements are discussed in detail with the customer. This is followed by the gradual assembly of the Eldec MIND system, selecting the required key components, i.e.: basic machine, energy source, inductor, coolant system and automation components, where required."

**High-efficiency, precision-dosing.** The

machine builder relies on their accumulated know-how and quality details for every component, resulting in a machine that considerably improves the economic viability of the process. For example:

The basic machine base is constructed of massive, high-prec-

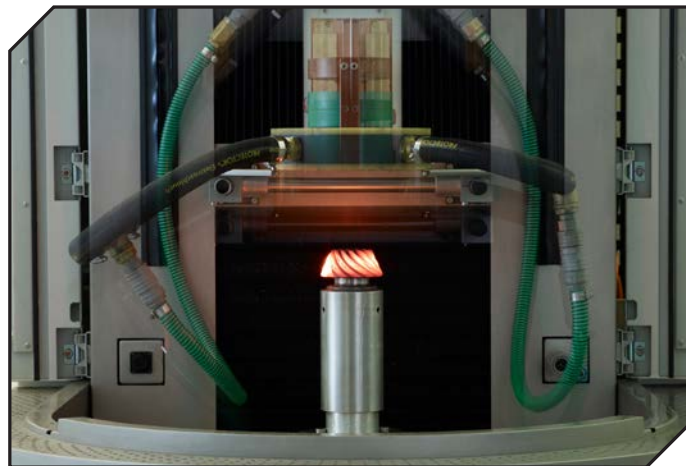

Figure 2 Processing a drive pinion – from hardening to chamfering – takes 14 seconds.

sion welded components and includes the main column for the Z-axis. The vibration-resistant construction ensures top machining accuracy. Depending on the clamping system used, Eldec machines can accommodate workpieces up to 1,200 mm diameter.

Available generators are microprocessor-controlled, single- or dual-frequency, with a capacity of 5 to 3,000 kW. They are highly efficient and allow the required energy to be adjusted with great precision. Their performance also adjusts itself automatically — and with equally great precision — to that of the inductor used.

The inductor/tools are manufactured according to customer specification, using 3D-CAD software. Made with the help of state-of-the-art machinery by an experienced staff, they are of micrometric accuracy.

Performance data of the MIND technology Eldec is capable of processing a driving pinion in as little as 14 seconds. The component is, through automation or manually, inserted into the indexing table of the machine and the hardening process takes between 100 milliseconds and a few complete seconds. After quenching, the hardened steel is gradually tempered and the machining cycle is completed with the subsequent cooling process. "Of decisive importance to us is not just the high speed of the process,



Figure 1 Manually loaded, semi-automatic or production line-integrated – the modular design of the MIND-system suits every production environment (All photos courtesy Eldec).



# YOUR ONE STOP GEAR SHOP

EXCEPTIONAL CAPABILITIES. EXCEPTIONAL QUALITY.

## MANUFACTURING

**Our latest machine capacity** allows us to cut bevel, spur and helical gears up to 4 meters in diameter. We can produce straight, skew and spiral bevel gearing using either the Gleason or Cyclopalloid system. We can cut spur or helical gear teeth in pitches up to 100 module (0.25 DP), and bevel teeth in pitches up to 50 module (0.5 DP).

## HEAT TREAT

**Overton Chicago Gear's state-of-the-art facilities** include a 30,000 square foot heat treatment facility capable of supporting all or your gearing requirements. We have the technology to produce gearing in thru-hardened condition up to 400 Bhn or case hardened to your specifications. We can carburize and press quench gearing up to 2.2 meters diameter.

## QUALITY

**Our modern, state-of-the-art, climate-controlled gear metrology laboratory** is capable of measuring to AGMA 2000, AGMA 2015, ISO 1328, and DIN 3960 gear accuracy tolerances. We are the experts in large diameter bevel and ring gears with quality up to DIN 5/6 (AGMA 12/13). We are ISO 9001:2008 registered.

## CHICAGO ADDISON LOMBARD

(630) 543-9570 | [www.oc-gear.com](http://www.oc-gear.com) | [sales@oc-gear.com](mailto:sales@oc-gear.com) | Founding member of AGMA



**OVERTON CHICAGO GEAR**  
An HDAM Company



REGISTERED TO ISO 9001

but also the precision of the hardening operation,” states Krause. “For instance, on Eldec machines the variation in effective hardening depth is no more than  $\pm 0.1$  mm, an extremely low value within hardening technology.”

**Benefitting from general trends.** With these trends, Eldec is benefitting in the automotive and aviation industries. The geometries of many components are becoming more complex and, at the same time, pieces tend to get smaller. The hardening process must keep pace with this development and guarantee the

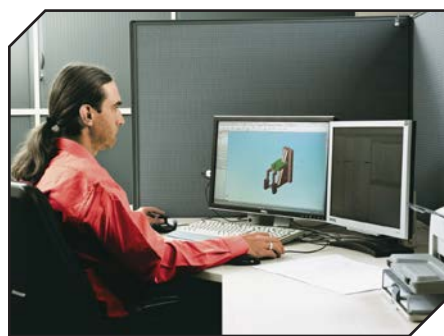

**Figure 3** The Eldec shape of the tool is designed with great precision using 3D CAD software by specialist in inductor design.

required quality, despite more demanding basic conditions, and the MIND series of machines is a very good start, Eldec offering more flexibility to the workflow by providing suitable automation. The machines are available ranging from manually loaded stand-alone solutions to fully integrated, in-line hardening cells for the soft- and hard-machining of components.

Particularly in the emerging Asian markets, large automobile manufacturers rely on Eldec machines when establishing new production facilities. “In China, for instance, the production quality of components has to be on par, in every respect, with those from Europe or the United States. We offer the hardening machine technology they need. It is a technology that impresses with its economic processes,” concludes Krause.

**Three advantages of MIND induction hardening machines.** 1) Precision: All machine components and the inductor are specially made to suit the component to be hardened. Eldec know-how guarantees production with dimensionally accurate processes. 2) Well-built: This modular design relies entirely on well

proven, sturdy components with optimal price-performance ratio. 3) Efficiency: Machine, generator performance, and automation options ensure fast processing and low component manufacturing costs.

Manually loaded, semi-automatic or production line-integrated – the modular design of the MIND-system suits every production environment.

The machining area is fixed with an indexing table, spindle drive, and tail-stock equipped to suit the workpiece (here a drive shaft). MIND machines are designed for workpieces between 250 and 1,500 mm diameter. ⚙️

#### For more information:

Sales Contacts  
Mark Davis, inside sales manager  
Eldec USA  
3355 Bald Mountain Road  
Auburn Hills, MI 48326  
Phone: (248) 630-7755  
mdavis@Eldec-usa.com  
www.Eldec-usa.com

Peter Loetzner, CEO  
EMAG LLC  
38800 Grand River Ave  
Farmington Hills, MI 48335  
Phone: (248) 477-7440  
info@usa.emag.com  
www.emag.com

# LUREN

PRECISION CO., LTD.

## ENGINEERED FOR PERFECTION



### EXCLUSIVE LUREN QUALITY

Providing our customers with excellent tool life, high quality and great performance, year after year: With over 25 years of gear cutting tool design and manufacturing experience, we have continuously studied and refined our manufacturing process to confidently offer 100% defect-free gear cutting tools.

### Luren offers

- hobs
- carbide hobs
- shaving cutters
- shaper cutters
- master gears



#### Headquarters

Luren Precision Co., Ltd.  
No 1-1, Li-Hsin 1st Rd., Hsinchu Science Park, Hsinchu 30078, Taiwan  
Phone: +886-3-578-6767 Fax: +886-3-578-4933  
Email: sales@luren.com.tw

#### Luren Precision Chicago Co., Ltd.

707 Remington Road, Suite 1, Schaumburg, IL 60173, USA  
Phone: 1-847-882 1388 Fax: 1-847-882 1933  
Email: Gerald\_kuo@luren.com.tw Darian@lurenchicago.com

**NORTON**

SAINT-GOBAIN

**VITRIUM** 

**REVOLUTIONARY BOND TECHNOLOGY**

NEW GENERATION,  
PATENT-PENDING BOND SCIENCE.



# RESHAPING THE WORLD OF PRECISION GRINDING

COOL CUTTING | PRECISE PROFILE | HIGH SPEED



GEAR



AEROSPACE



BEARING



AUTOMOTIVE



ENERGY

For more information, visit us [www.nortonindustrial.com/vitrium3](http://www.nortonindustrial.com/vitrium3)  
or email us at [contactnorton@saint-gobain.com](mailto:contactnorton@saint-gobain.com).

© Saint-Gobain Abrasives, Inc. 2013

# New ECM Furnace Improves Manufacture Efficiency of PM Components

Hubert Mulin, Jean-Jacques Since,  
Yves Giraud and Mats Larsson

The heat treatment processing of powder metal (PM) materials like Astaloy requires four steps—de-waxing, HT sintering, carburizing and surface hardening—which are usually achieved in dedicated, atmospheric furnaces for sintering and heat treat, respectively, leading to intermediate handling operations and repeated heating and cooling cycles. This paper presents the concept of the multi-purpose batch vacuum furnace, one that is able to realize all of these steps in one unique cycle. The multiple benefits brought by this technology are summarized here, the main goal being to use this technology to manufacture high-load transmission gears in PM materials.

## Introduction

Today, the usual way to manufacture PM parts like gears is divided into several steps. When the gear is shaped by die compaction, four heat treatment stages must be carried out in order to acquire all the required properties. These four stages are de-waxing, sintering, carburizing treatment, and quenching.

Most of the time, de-waxing and sintering are performed in continuous-belt or walking-beam furnaces. The first operation, de-waxing, is intended to remove the lubricants. This is a critical step because if removal of the lubricant is incomplete, defects like contamination, blistering, etc., might present. Belt or walking-beam furnaces are able to sinter directly after de-waxing in a single run, which presents an advantage compared to the use of two dedicated furnaces. After sintering, the carburizing treatment for tailored, case-hardened profile produces the final, required properties and is generally fol-

lowed by hardening, using oil quench or high-pressure gas quenching (HPGQ).

Typically, the conventional carburizing treatment is done in batch-type furnaces. This requires intermediate handling between sintering and carburizing, and post washing-and-drying operations after oil quenching.

This article presents the concept of a multi-purpose furnace that performs the mentioned successive steps in one continuous cycle. The discussion will focus on benefits of this furnace and associated cycles, and compare the traditional method of sintering and carburizing to this concept.

## Experimental Details

Trials have been carried out with a Höganäs AB industrial furnace (Fig. 1), designed and manufactured by ECM Technologies. The furnace comprises two chambers—one heating cell and one gas

quenching cell—separated by an intermediate leak-tight and insulated door.

The front chamber is used as an airlock to load and unload the charge and also as high-pressure gas quenching unit for hardening the parts.

The second chamber—or “heating cell”—is the furnace itself where parts are heated and carburized. It is always maintained under low pressure (1 to 20 mbar) with back-fill of protective atmosphere.

Each chamber is equipped with independent vacuum circuits and can be operated independently. The vacuum circuits are designed to maintain the correct partial pressure inside the heating chamber, and are equipped with a wax trap to collect the lubricant during the de-waxing cycle.

One internal device transfers the load back and forth between the two chambers; a service door facilitates the access to the heating chamber for periodic temperature mapping instrumentation or maintenance. Figure 2 displays the complete treatment cycle in the multipurpose furnace.

The de-waxing step is performed at around 650°C under low pressure. At this temperature the lubricant evaporates and is being pumped out by the vacuum circuit; it is entirely removed from the parts and collected in the wax trap. The temperature is then increased to reach the desired sintering temperature (up to 1,250°C). At this stage, metallic bonds between particles are formed. After sintering is completed, temperature is



Figure 1 Multi-purpose vacuum furnace installed in Höganäs pilot plant.



decreased to reach the desired carburizing temperature (900 to 1,000°C). Then follows the patented (Ref. 1) Infracarb process, where the low-pressure carburizing cycle with alternating injections of acetylene and nitrogen is carried out. The number of injections and cycle time is adjusted, depending on the desired case depth. After final diffusion, the load is transferred back to the front chamber, and is quenched with nitrogen gas (up to 20 bars). Metallurgical transformation occurs during the rapid cooling and enhances the mechanical properties of the parts.

For example, a 300 kg load containing small spur gears has been carburized at 965°C for 74 minutes, and the effective case depth at 550HV obtained is 0.6mm (Fig. 3).

## Discussion

For each step, the new concept is compared to the traditional way to manufacture PM parts.

**De-waxing.** When the parts reach a temperature above 400°C, lubricants used during die compaction evaporate. Typical lubricants, such as amide wax, are totally decomposed between 400 and 500°C.

In the pre-heating zone of belt-type furnaces, lubricant vapors are mixed with protective atmosphere and burnt as exhaust. With conventional belt furnaces, the de-waxing time and the sintering time are linked and defined by the belt's length and speed.

In a multi-purpose furnace, a partial pressure of nitrogen (1 to 20 mbar) preserves the parts from oxidation. The vaporized lubricant is condensed and collected in a trap in the vacuum circuit. The de-waxing time can be easily increased or decreased according to the load's weight. The trap reduces the rejects in the atmosphere and keeps the vacuum circuit clean. Vacuum is also well known to be an efficient way to de-wax the part. De-lubrication under vacuum is thus beneficial to the de-waxing rate.

**Sintering.** Many parameters are crucial during sintering, especially the time and temperature of sintering, the heating rate, and also the design of the fixtures, the arrangement of the parts on the trays, etc.

Sintering temperature (around 1,200°C) is about the maximum limit to be used in traditional furnaces, and reaching it impacts the lifetime of the

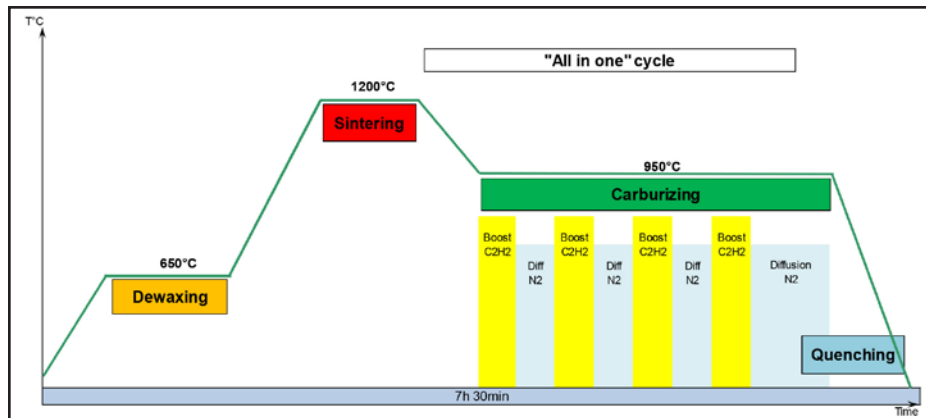

Figure 2 Complete treatment cycle for PM parts.

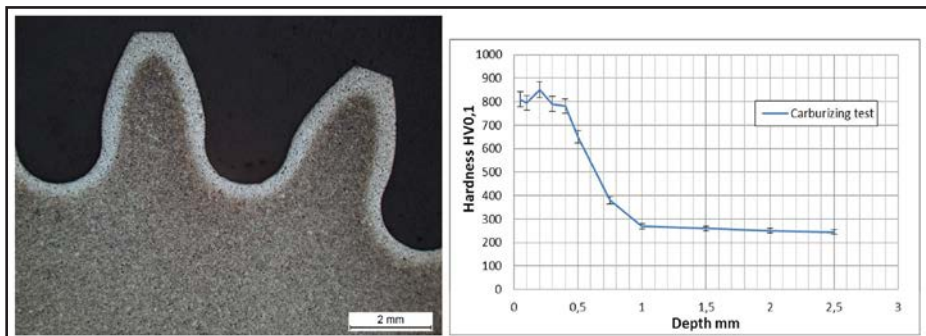

Figure 3 Part etched with nital 2% and hardness profile.

heating elements (radiant tube). In vacuum furnaces, the lack of oxygen permits the use of graphite rods as heating elements. Graphite rods are very stable mechanically (no bending with temperature), and the lifetime is not influenced by the working temperature.

PM compacts, especially chromium alloys, are prone to oxidation and so precise control of atmosphere quality is required. Due to the open pore system, PM compacts are more prone to oxidation than wrought steel. Residual oxidation can introduce defects during sintering. A continuous furnace uses a reducing gas like hydrogen to protect the parts, which is not necessary under vacuum. All the other parameters (heating rate, sintering time, etc.) can be easily adjusted to obtain the best sintering process.

**Carburizing.** The absence of handling between operations in the multipurpose furnace guarantees that the parts will not be affected by contamination or damaged between sintering and heat treatment.

Frequently, batch furnaces are used for carburizing PM parts. Carbon enrichment is controlled by O<sub>2</sub> sensors or CO/CO<sub>2</sub> ratio.

In the new furnace, the carburizing phase is completely controlled by

Infracarb, the patented LPC process with acetylene gas. The case depth and carbon profile are simulated and adapted for porous materials. Low-pressure carburizing processes can be achieved at any temperature up to 1,050°C. The carbon enrichment and diffusion time can be controlled separately to achieve the required microstructure.

The cycle is shortened and diffusion is faster than in an atmospheric carburizing furnace. Moreover, there is no internal oxidation of the parts. The amount of carburizing gas injected in the chamber is optimized to ensure that every part is correctly carburized. Injection is done by short bursts in order to minimize the formation of gas constituent, which leads to volatile organic components and atmospheric rejects are reduced.

**Quenching.** The high-pressure gas quench allows a range of appropriate cooling speeds (from 1 to 10°C/sec) to be reached; Figure 4 shows the principle of the gas quench chamber. Cold nitrogen gas is pushed down through the load, cooling it, and transfers the heat to the water when passing the heat exchanger. Gas quenching permits high flexibility and more repeatable results than oil quenching, because there is no boiling or

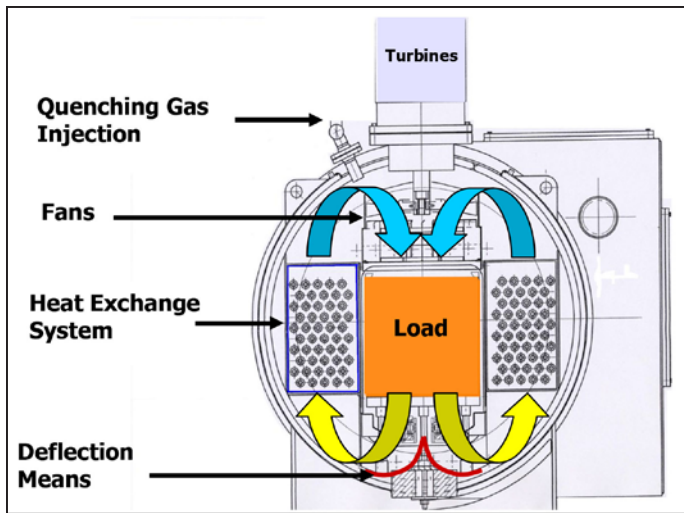

Figure 4 Principle of gas quench chamber.

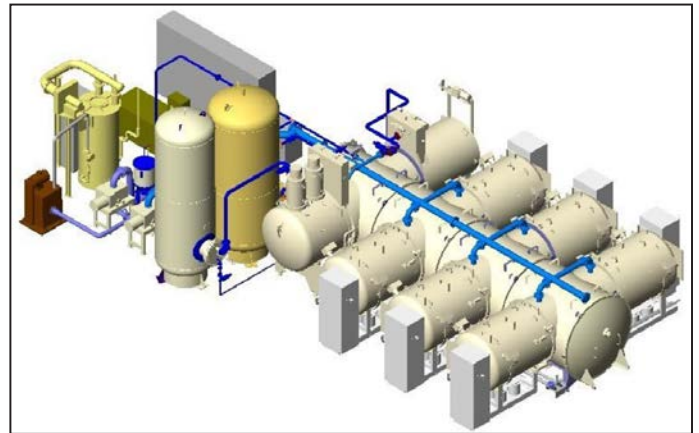

Figure 5 Modular sintering multi-cells line type ICBP.

vapor formation around the parts. With a gas quench, the pressure and also the turbine's speed can be programmed for each cycle in order to adjust the cooling rate for every type of load, thus minimizing parts distortion. The parts exit the furnace clean with no need of washing.

### Process Cost Estimation

For typical production of 300 kg net/hour, a modular vacuum installation with multiple heating cells is required (Fig. 5). Based on an engineering cost estimate, the cost of sintering and heat treatment of parts is about 0.5€/kg.

The precise cost depends on the geometry and hardenability of different kinds of parts.

The main saving factor comes from the fact that carburizing and gas quench steps are carried out in situ in the de-waxing/sintering equipment. The maintenance cost per year for an ICBP-type furnace is around 4% of the investment cost, or lower. The high modularity and reduced footprint of the furnace is also an advantage.

The global energy balance cost is positive against the conventional furnace because there is no multiple cool down and reheating of the parts for each step of the process.

The modularity of the heat treatment installation allows for further production extension by the simple addition of heating cells on the mainframe without investment in a second line.

### Conclusions

Studies have been carried out in partnership with Höganäs AB on different alloys,

including chromium alloys. Positive results have been achieved on:

### Control of Case Profiles

Control of core hardness with base carbon content and cooling speed variation

Low-pressure carburizing has been proven very suitable for control of process parameters without oxidation.

The multi-purpose furnace potentially offers an improvement at every stage of the PM production process: It will be the tool for further optimization to improve mechanical properties like fatigue strength, distortion reduction, and validation of the entire process for the production of high-performance PM gears.



### References

1. U. S. Patent No. 6,065,964, May 23, 2000.

#### For more information:

ECM Technologies  
Hubert Mulin  
PhD engineer and R&D process manager  
Phone: +33 - (0) 476 49 65 60  
[h.mulin@ecmtech.fr](mailto:h.mulin@ecmtech.fr)

Jean-Jacques Since  
Area sales manager  
Phone: +33- (0) 476 49 65 60  
[jj.since@ecmtech.fr](mailto:jj.since@ecmtech.fr)

Yves Giraud  
Process manager  
Phone: +33 - (0) 476 49 65 60  
[y.giraud@ecmtech.fr](mailto:y.giraud@ecmtech.fr)

Höganäs AB  
Mats Larsson  
Manager, PM components/process development  
Phone: + 46 42 338000  
[mats.larsson@hoganas.com](mailto:mats.larsson@hoganas.com)

For Related Articles Search

powder metal

at [www.geartechnology.com](http://www.geartechnology.com)

**Yves Giraud** is process manager for ECM Technologies.

**Mats Larsson** studied mechanical engineering at Lund University (Sweden). He joined Höganäs AB in 1988, working in various positions within the development department, and, in 2009, was appointed manager of PM components/process development. Larsson is also chairman of the ISO standardization committee TC119/SC2: Powder Metallurgy Sampling and Testing Methods of Powders.



**Hubert Mulin, PhD** engineer and R&D process manager for ECM Technologies, received his undergraduate engineering education at the ECAM School (Catholic school of Arts) in Lyon, France. He then went on to earn a research master's degree in material sciences based on low-pressure carburizing sensors. He subsequently received his doctorate—with a focus on shaping metal powders using MIM (metal injection molding) technology. Mulin joined ECM Technologies in 2012 as an R&D process manager.



**Jean-Jacques (JJ.) Since** joined ECM in 1992 as an export sales manager for vacuum furnaces and special heat treatment plants. He studied solid state physics and the science of materials at INSA — Toulouse (Institut des Sciences Appliquées). Since is a member of CECOF (European Committee of Industrial Furnace and Heating Equipment Associations).



# I Rely on Arrow Gear



## High Quality Gears for the Biomedical Industry

Every day, thousands of health care professionals around the world rely on the exacting quality of every component of their biomedical systems - especially the gears which are produced by Arrow Gear Company.

With over 65 years experience, Arrow Gear's products are used throughout the world in advanced technologies that save people's lives. With a state-of-the-art production facility and dedicated personnel who are among the best in the business, Arrow Gear offers the expertise and precision for the most demanding quality requirements.

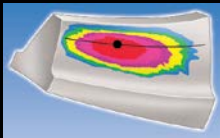

Arrow Gear also offers leading edge design and development capabilities ensuring new designs meet performance specifications without costly delays.

**When you need quality, expertise, and precision,  
you can rely on Arrow Gear!**



Visit Arrow Gear's  
Virtual Tour at  
[www.ArrowGear.com/tour](http://www.ArrowGear.com/tour)

The Precision Gear Specialists



[www.ArrowGear.com](http://www.ArrowGear.com)  
6 3 0 . 9 6 9 . 7 6 4 0

# Press Quenching and Effects of Prior Thermal History on Distortion during Heat Treatment

Arthur C. Reardon

Precision components (industrial bearing races and automotive gears) can distort during heat treatment due to effects of free or unconstrained oil quenching. However, *press quenching* can be used to minimize these effects. This quenching method achieves the relatively stringent geometrical requirements stipulated by industrial manufacturing specifications. As performed on a wide variety of steel alloys, this specialized quenching technique is presented here, along with a case study showing the effects of prior thermal history on the distortion that is generated during press quenching.

## Introduction

Press quenching is a specialized quenching technique that may be utilized to minimize the distortion of complex, geometrical components during heat treatment (Ref. 1). Distortion is routinely encountered in industrial heat treating operations, and is an especially important consideration where high-accuracy, precision components are concerned. It can result from a wide variety of independent contributing factors. With press quenching they include:

- The quality and prior processing history of the material from which the part in question has been manufactured
- The prior thermal history and residual stress distribution contained within the part
- The generation of unbalanced thermal and transformation stresses induced by the quenching operation
- The grade of material and austenitizing temperature that is used
- Transfer time between the austenitizing furnace and the quenching machine
- The type, condition, quantity and temperature of quenchant used
- Direction and selective metering of quenchant flow over the component
- Duration of the quench at various flow rates
- Locations of contact points on the component for applying external loads
- Magnitude of the forces applied for maintaining the required part geometry
- Proper quench die tooling design, set-up and maintenance
- Pulsing methodology

## Distortion Issues during Quenching

High-precision components such as automotive spiral bevel gears and aerospace-quality bearing races can often distort appreciably during open-tank oil quenching. Press quenching can help to minimize the distortion of such components by uti-

lizing specialized tooling for generating concentrated forces at key locations to constrain the movement of the component in a carefully controlled manner. It can be performed on a wide variety of components manufactured from both ferrous- and non-ferrous-based alloys. For example, a number of aluminum alloys are routinely press-quenched. Common steel alloys that are press-quenched include high-carbon, through-hardening grades such as AISI 52100 and A2 tool steel. Press quenching is particularly well-suited for the process of carburizing steel grades such as AISI 9310, 8620 and 3310.

Ideally, the transformation temperature should be the same throughout the entire cross-section of the component during quenching so that the material is capable of transforming in a uniform manner. However, in case-carburized parts the martensite start transformation temperature ( $M_s$ ) is not uniform throughout the entire cross-section of the part. During carburization a composition gradient is produced as carbon is diffused into the part surface. This results in a corresponding gradient in the transformation temperature near the surface that can promote or aggravate distortion issues in these components during quenching. Non-uniformities in the base material microstruc-



Figure 1 A modern quenching machine (All images courtesy The Gleason Works).

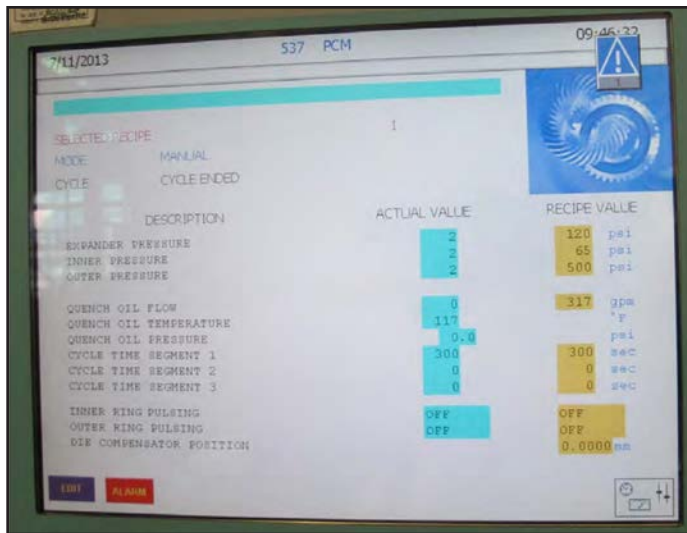

**Figure 2** Control screen showing the various parameters that may be adjusted over the course of a typical quenching cycle.



**Figure 3** Hot bearing race positioned on the lower die assembly of a quenching machine just before it is retracted into the machine for quenching. Note the segmented die tooling and individual slotted rings. The slotted rings may be independently adjusted to control the flow of oil over the part being quenched.

ture due to segregation or improperly normalized material can also contribute to this type of distortion. Thin-walled components such as large-diameter bearing races are generally more susceptible to these distortion-related issues than are relatively massive, compact geometries. Although press quenching cannot eliminate these effects, its use can help to minimize their contribution to the overall distortion that is produced during heat treatment.

The amount of distortion encountered depends strongly on the nature of the heat treating process that is used. In order to minimize distortion-related issues during quenching, heat should be extracted from the component in as uniform a manner as possible. For parts that are designed with sudden changes in geometry with heavy or thick sections located adjacent to relatively thin sections on the same component, this can be difficult to achieve. A good example of this is the teeth on a spiral bevel gear or pinion. The teeth have a greater surface area-to-volume ratio than the body of the gear or pinion, and due to their symmetrical nature and distribution the teeth have a tendency to distort by unwinding during quenching. As the workpiece is submerged in the quenching medium, the teeth tend to cool and contract much more rapidly than the adjacent, heavier sections. As a result of this varying quench rate, the teeth harden more rapidly and contract, while the balance of the component is still in an expanded state. The outcome of quenching such components in this way is the generation of temperature gradients and non-uniform transformation-induced stresses. This particular issue can be addressed in press quenching by selectively directing the quenchant flow toward the thicker sections and baffling it away from the teeth in order to promote a more uniform quench. By implementing this important technique, lower levels of transformation-induced distortion can be achieved.

## Press Quenching Machines

A representative version of a standard quenching machine is depicted in Figure 1, and examples of the numerous parameters that may be adjusted during the course of a typical quenching cycle are shown on the machine's main control screen in Figure 2. During operation, the component to be quenched is removed from a separate furnace (usually a box, continuous rotary, or pusher-type furnace) and is placed onto the tooling of the lower die assembly (Fig. 3)

After the part is successfully loaded onto the lower die assembly, the machine is actuated and the part is retracted into the machine where it is centered below the upper hydraulic ram assembly. As the assembly descends, the center ram actuates one or more internal expanders that make contact with the inner diameter of the component at specified points to maintain roundness at these locations (Fig. 4). Each component of the ram assembly (the center expander, inner and outer dies) is controlled independently through three separate, proportional valves. A predetermined pressure level is usually maintained by the expander throughout the quench cycle. The inner and outer dies are lowered to make physical contact with the upper surfaces of the component being quenched in order to control alignment, dish and part flatness during the course of the quenching cycle. The flow of quench oil is then activated to quench the part.

Figure 4 illustrates an example of a quench oil circulation path that can be established within the quenching chamber. Oil is pumped into the quench chamber through apertures around the outside diameter of the lower die. As the chamber fills up surrounding the component, oil flows out of the top. If the tooling is properly designed, the direction of oil flow over the component can be adjusted to obtain the best overall results. The elongated apertures at the exit may be adjusted to restrict oil flow, or may be fully opened to maximize flow, depending upon the requirements of the part in question. The lower dies are constructed from several different concentric, slotted rings that may be rotated to provide full flow or to restrict oil flow to the

For Related Articles Search

press quenching

at [www.geartechnology.com](http://www.geartechnology.com)

underside of the part. These particular features can be finely adjusted to help minimize the degree of distortion attributed to uneven heat removal during quenching. Timed segments during the quenching cycle can also be utilized to vary both the oil flow rate and duration in order to establish a well-defined quenching recipe for a specific part design.

The oil quenching process itself may consist of up to three general stages: (1) the initial vapor blanket stage where the first oil to come in contact with the part is instantly vaporized and forms a vapor barrier that surrounds the part and acts as an effective thermal-insulating layer; (2) the vapor transport stage where oil breaks through the vapor blanket, resulting in more rapid heat transfer; and (3) the liquid stage where heat extraction occurs primarily via convective heat transfer. In order for uniform heat extraction to occur during the initial stages of quenching, the oil flow rates must be sufficient to prevent

the formation of a vapor blanket. If vapor bubbles are allowed to form in areas around the surface of the component, uneven heat extraction will result that can lead to unacceptable hardness variations and distortion. After this initial quenching stage has been successfully eliminated, lower quenchant flow rates can be safely tolerated. The quenchant flow rate profile that is ultimately established for the part in question must be carefully selected so that the hardness and geometry requirements are satisfactorily met. Too slow of a quench rate will result in a slack quench, undesirable transformation products, and hardness variations. Too rapid of a quench rate could result in cracking and/or unacceptable part distortion. The establishment of an oil flow path around the part and selection of the proper oil flow rate are often determined using a trial-and-error process. Success frequently depends upon the knowledge, experience and skill of the machine operator.

The average oil temperature for most press quenching operations typically falls somewhere within the range of approximately 75°F–165°F—depending upon the material in question, the nature of the quenching operation, the type of quench oil being used, and post heat treat property requirements. Average quench oil temperatures exceeding 140°F should generally be avoided as a precaution to prevent damage to the machine seals that are used to contain the quench oil. Proper and routine maintenance of the quench oil bath is an often-neglected aspect of the press quenching process, and can lead to unexpected variations in the hardening response of the materials processed in these types of systems. As the quench oil continues to be used, the oil additives gradually break down and fine particulates can accumulate over time—even if the oil is continuously filtered. If left undetected this can lead to accelerated quench rates that can compromise the integrity of the oil quenching process.

A specific die tooling design configuration and machine setup are required for each component that is press quenched. The

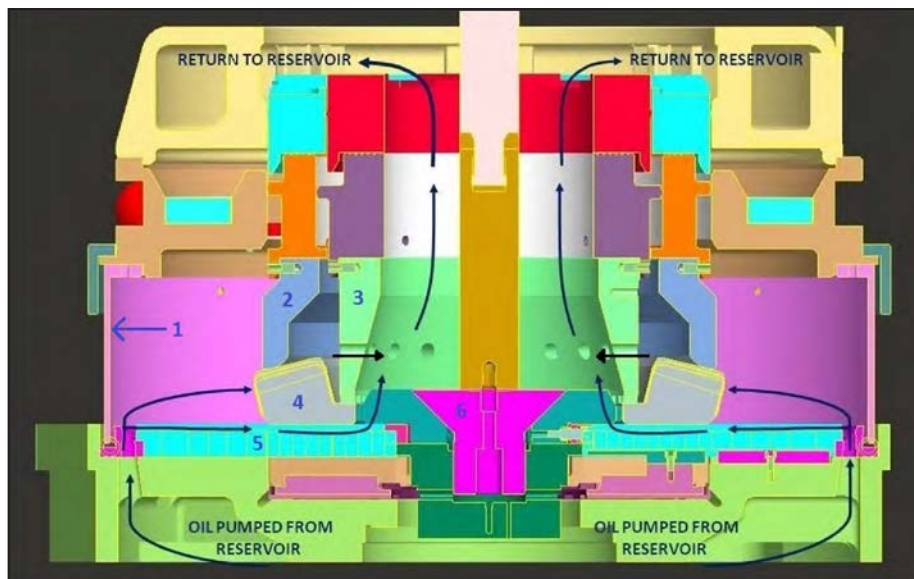

**Figure 4** A schematic cross-sectional diagram illustrating the contact of the center expander and the inner and outer dies with the part during quenching. The various components labeled in the diagram are: (1) the machine guard attached to the upper die assembly; (2) outer upper die; (3) inner upper die; (4) component undergoing quench; (5) lower die assembly; and (6) center expander cone. The oil flow path through the quench chamber is depicted by the flow line arrows.

use of expanding, segmental dies is often employed to maintain bore size and roundness in bearing races and gears. If a component possesses a bore diameter that is physically too small to accommodate these segmental dies, a solid plug could be used instead to control the diameter and taper of the bore; the plug is simply removed after quenching. When there are different locating surfaces on the lower die assembly, it is imperative that the dimensions between these surfaces be held to a close tolerance from piece to piece. Failure to adhere to this rule could result in unwanted distortion and/or inconsistent results. Contracting dies are also available to maintain the geometrical tolerances for the outside diameter of components where this is a critical factor. A good example of this are gears that incorporate thin web sections in conjunction with relatively heavy sections for gear teeth, bosses, and bearing diameters. Gears used in aerospace applications such as helicopter gear assemblies often incorporate several of these features that may cause them to contract unevenly during quenching. This problem can be effectively remedied by the application of compressive loads on the outside surface of the component during press quenching.

It should also be noted that the inner and outer dies are typically pulsed during quenching to maintain the geometry of the part and to minimize distortion. The pulse feature periodically eases the applied pressure exerted by the inner and outer dies, allowing the component to contract normally as it cools while still maintaining the desired part geometry. If this feature was not incorporated (and on some of the older machines it isn't available), the stresses that would be induced from frictional contact between the die assembly and the component would not allow it to contract normally as it cools. Pulsing effectively reduces this frictional contact and avoids distortion-related issues due to eccentricity and out-of-flatness. The pulsing technique keeps the dies in contact with the part throughout the entire quenching cycle, but allows the pressure to be released

and then re-applied approximately every two seconds. The inner and outer dies are typically cycled in this manner; however, the expander pressure is not normally pulsed.

## Case Study

As mentioned, the dimensional tolerances achieved during quenching are strongly dependent upon the various factors that can contribute to part distortion. The prior thermal history and residual stress distribution contained within the part can contribute significantly to distortion-related issues during heat treatment, and this is certainly true during press quenching as well. A case study that clearly illustrates this point was conducted on a number of automotive gears that were manufactured from AISI 8620H—a chromium-nickel-molybdenum case-carburizing steel that is commonly designated for use in gearing applications. The outside diameter of these machined gears measured approximately 13¾ inches prior to austenitizing and press quenching. They were processed on two separate furnace loads. For the first set of gears, designated Series 1, the normalizing temperature used was 1700°F. These gears received a single normalizing cycle. The second set of gears, labeled Series 2, was normalized twice in succession. The first normalizing cycle they received was identical to that used for the Series 1 gears. For the second normalizing cycle, the temperature was raised to 1,750°F. Each group of 24 gears was subsequently processed through a gas-carburizing furnace using an endothermic atmosphere at a temperature of 1,700°F to generate effective case depths in the range of 0.040–0.055 inches. The gears were all cooled to room temperature after carburizing was completed. They were then reheated to the austenitizing temperature of 1,570°F and individually press-quenched.

The resulting distortion that was measured on the outside diameter of these gears in terms of out-of-round is shown in Figure 5. Examination of this chart reveals that the gears normalized once at 1,700°F (Series 1) exhibited substantially greater amounts of distortion in terms of out-of-round than the gears which were normalized twice using a final temperature of 1,750°F (Series 2).

## Summary

Press quenching is a specialized quenching technique that may be utilized to minimize the distortion of complex, geometrical components during heat treatment. It is a versatile and time-proven technique that can accommodate a wide variety of material grades and component geometries. The success of this technique depends strongly on a large number of variables. Some of the more important among these variables include the knowledge, skill and experience of the machine operator. In this investigation, the prior thermal history of the material was also dem-

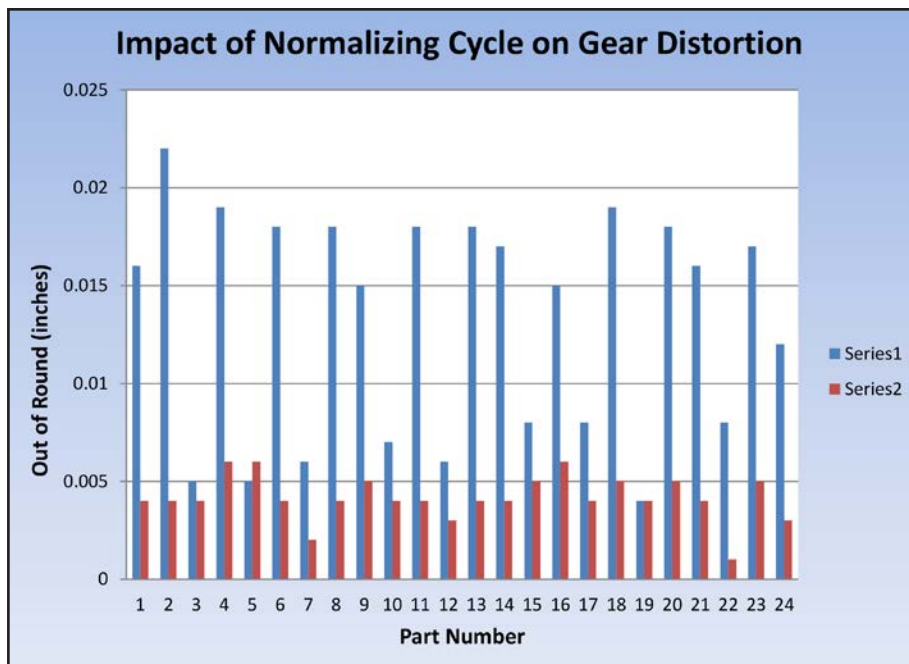

**Figure 5** Out-of-round measurements on two different groups of case-carburized AISI 8620H gears after press quenching and tempering. These gears originally measured approximately 13.75 inches in diameter. There were 24 gears evaluated per group; each group was normalized using different cycles (see text for a description of these cycles). The numbers that appear on the horizontal axis in this chart each represent two gears—one gear randomly selected from Series 1 (blue) and one gear randomly selected from Series 2 (red). Note the dramatic improvement in out-of-round on the Series 2 gears.

onstrated to be an important—and often overlooked—variable as well. ⚙️

## References

1. Reardon, A.C. "Press Quenching," *ASM Handbook*, Volume 4a, *Steel Heat Treating Fundamentals and Processes*, J. Dossett and G. Totten, Editors, ASM International, Nov. 2013.

**Dr. Arthur C. Reardon** is corporate metallurgist for The Gleason Works in Rochester, New York. He earned his bachelor's degree in physics and mathematics at the State University of New York College at Oswego (1986), and later his MS in mechanical and aerospace sciences and his PhD in materials science at the University of Rochester. He is an experienced professional in materials science, engineering, and metallurgy, with extensive experience in research and development, alloy design, process metallurgy, mechanical engineering, material selection, and customer technical support. Dr. Reardon has worked in industry for over 20 years; more than 10 years were spent working as a senior process metallurgist in the steel production industry, where he led projects in the melting, forging, rolling, finishing and inspection operations. He also provided metallurgical support for the annealing and heat treating operations, including processing of a large number of steel types and specialty steels. He has collaborated on the design and development of state-of-the-art alloys using both traditional air-melt and powder metallurgy processing techniques. Reardon has worked as an adjunct assistant professor at the L.C. Smith College of Engineering at Syracuse University, where he taught a junior level engineering for nine years. He earned his PE license in the discipline of metallurgy, and is licensed in several states. He has authored many technical papers on subjects from low-temperature physics and fracture mechanics to the simulation of atomic solidification processes, laser theory, and astrophysics. Reardon is a longtime member of ASM International and currently serves on its International Technical Books Committee. He also wrote the book, *Metallurgy for the Non-Metallurgist* (Second Edition, ASM International, 2011), which received the prestigious Outstanding Academic Title award by *Choice Magazine* in 2013, which is currently in its fourth printing.



# Technological Potential and Performance of Gears Ground by Dressable CBN Tools

Jan Reimann, Fritz Klocke, Markus Brumm, Andreas Mehr and Klaus Finkenwirth

Dressable vitrified bond CBN grinding tools combine the advantages of other common tool systems in generating gear grinding. Yet despite those technological advantages, there is only a small market distribution of these grinding tools due to high tool costs. Furthermore, scant literature exists regarding generating gear grinding with dressable CBN. This is especially true regarding the influence of the grinding tool system on manufacturing-related component properties. The research objective of this report is to determine the advantages of dressable CBN tools in generating gear grinding.

## Introduction

In order to improve load carrying capacity and noise behavior case hardened gears usually are hard finished. One possible process for hard finishing of gears is generating gear grinding which has replaced other grinding processes in batch production of small and middle gears due to high process efficiency. Depending on grinding task and batch size different tool concepts can be used in generating gear grinding. The latest concept is dressable vitrified bond CBN grinding tools.

Dressable vitrified bond CBN grinding tools combine the advantages of other common tool systems in generat-

ing gear grinding. The CBN grains are a highly productive cutting material due to their high specific stock removal rate. Vitrified bonds are dressable and thereby very flexible. By dressing different profile modifications can be set up and constant gear quality can be guaranteed during the tool life time. Despite those technological advantages there is only a small market distribution of these grinding tools due to high tool costs. Furthermore, only a few published scientific analyses of generating gear grinding with dressable CBN exist. Especially, the influence of the grinding tool system on manufacturing related component properties has not been analyzed yet.

## State of the Art

**Generating gear grinding.** One of the most efficient processes for the hard finishing of gears in batch production of external gears and gear shafts is the continuous generating gear grinding. Generating gear grinding is used for the hard finishing of gears with a module of  $mn=0.5\text{ mm}$  to  $m_n=10\text{ mm}$  (Refs. 1, 2, 4). By the application of new machine tools, the process can be used for grinding large module gears (up to  $d_a=1,000\text{ mm}$ ) (Ref. 4).

The cylindrical grinding worm, whose profile equates a rack profile in a transverse section, hobs with an external gear (Fig. 1, left). The involute is generated by continuous rolling motion of the grinding worm and workpiece (Fig. 1, right). The involute is generated by continuous rolling motion of the grinding worm and workpiece by the profile cuts method (Refs. 5, 2). Profile cuts method in the generating processes means the profile form is generated by a

finite number of profiling cuts. Due to the closed grinding worm no generating cut deviations, known from gear hobbing, occur in generating gear grinding.

In comparison with other gear grinding processes, the stock removal rate in generating gear grinding is very high. In most cases, it is only limited by the reachable gear quality (Ref. 2). In generating gear grinding, always multiple points of the grinding worm are in contact. The number of contact points change continuously during the tool rotation, Error! Reference source not found. (right).

The contacts on the right and on the left tool flank are equal by an even number of contact points. This leads to a consistent distribution of forces. By an uneven number of contact points also the distribution of forces will be uneven. This leads to an inconsistent distribution of the cutting forces. In Figure 1, lower on the line-of-contact of the left tool flanks the forces are split in two contact points. On the right tool flank the cutting force is increased because only one point has contact. This fact can lead to a higher stock removal at this contact point and to a higher excitation. The consequence can be the appearance of profile form deviations that reduce the reachable gear quality. Scientific publications by Meijboom (Ref. 6) and Türich (Ref. 7) describe this theoretical relationship.

Publications, such as those listed in References 8, 9 and 10, and existing doctoral theses by Meijboom (Ref. 6), Türich (Ref. 7) and Stimpel (Ref. 11), show the influence of several parameters (axial feed, number of starts, etc.) on the process results. But several technological correlations have yet to be analyzed or verified in trials, and investigation of different tool systems cannot to date be found in the literature.

**Tool systems in generating gear grinding.** In gear grinding, usually two types

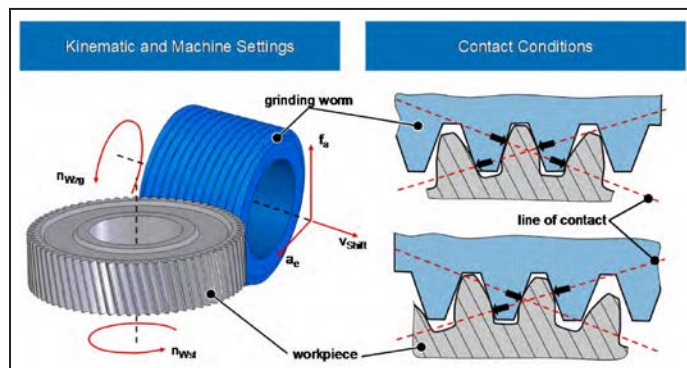

Figure 1 Generating gear grinding: principle, machine settings and contact conditions (all images courtesy WZL).



of tool systems are used. On one hand for small batch production with changing gear geometries and modifications flexible solutions are needed. Therefore, dressable vitrified bond grinding wheels made of corundum are used. A huge advantage is constant gear quality and surface roughness due to the possibility of dressing. A disadvantage can be found in short tool life times and additional dressing time.

On the other hand, for mass production with only a few variants concerning profile modifications a productive grain material is needed. Therefore, electroplated CBN tools are used. In contrast to dressable vitrified bond corundum tools electroplated CBN has a higher productivity due to wear-resistant grain material. A huge advantage is time saving due to reduction of dressing processes. But disadvantages can be found in changing gear quality during tool life time and the significant higher tool costs.

To combine the advantages of both tool systems vitrified bond dressable CBN tools have been developed. Due to high tool costs and existing risk in tool handling this tool system has not been used in many industrial applications so far. Furthermore, only a few published scientific analyses of generating gear grinding with dressable CBN exist (Refs. 13, 14, 15). What's more, the influence of the grinding tool system on manufacturing-related component properties has yet to be analyzed. But in recent years the tooling system has become increasingly attractive for industrial applications (Ref. 12).

## Objective and Approach

The research objective of this report is to determine the advantages of dressable vitrified bond CBN tools in generating gear grinding. The manufacturing-related properties of gears that are ground with dressable CBN will be analyzed and compared with conventional-ground gears.

The tested gear sets are manufactured identically despite the gear hard finishing process. In generating gear grinding, different tool systems are used for the hard finishing. The properties, e.g., surface structure, residual stresses and gear quality, are analyzed and compared.

After gear grinding, pitting tests according to the DIN-ISO standard for low cycle fatigue area are carried out

(Refs. 16, 17). In the end, a relation between different tool systems, manufacturing-related properties and fatigue strength will be demonstrated. Furthermore, initial results showing the tool wear behavior will be shown.

## Performance of CBN-Ground Gears in Fatigue Tests

In the following section the performance — especially the flank fatigue strength — of gears ground by different grinding tools, will be investigated in pitting tests. Therefore gear geometry, initial situation of the ground gears, test rig, and test approach are described. (Sample results to follow.)

## Workpiece Geometry, Test Bed, and Approach

**Geometry and initial situation of test gears.** For the fatigue strength test, a standardized, gear geometry of the Laboratory for Machine Tools and Production Engineering (WZL) was chosen. The gear set has a module of  $m_n = 4.0$  mm with 20 teeth at the pinion, 33 teeth at the wheel, and a gear face width of  $b = 21.2$  mm. The pressure angle is  $\alpha_n = 18^\circ$  and helix angle is  $\beta = 20.4^\circ$ . This leads to a standardized center distance of  $a = 112.5$  mm. The complete gear geometry data are shown in Figure 2.

All gear sets have been machined from the same material batch (20MnCr5) and have been heat treated in one batch. The gears are case-hardened with a case-hardening depth of  $CHD_{550HV} = 1.0$  mm at the flank, and a surface hardness of  $60 + 2$  HRC in one batch. All soft-machining operations, e.g., turning, milling and gear hobbing, have been carried out in each case with the same set of process parameter in one batch. The only differences can be found in the gear grinding process.

All gear sets were ground by continuous generating gear grinding with identical process parameters on the generating gear grinding machine LCS380 of LIEBHERR at the Laboratory

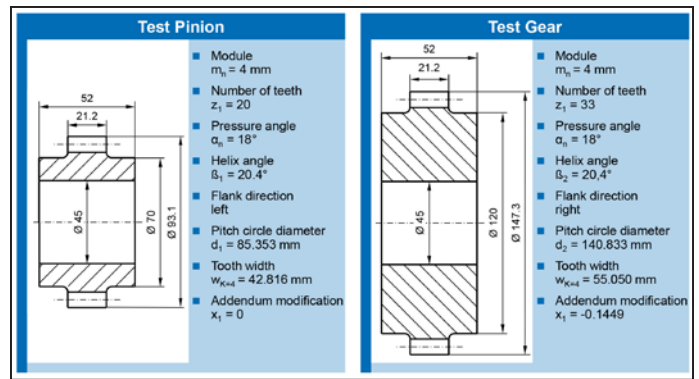

Figure 2 Gear geometry—test pinion and gear.

for Machine Tools and Production Engineering (WZL), RWTH Aachen University. Gears and pinions have been ground by a two pass strategy.

In the first pass, the gears were roughed with a cutting speed of  $v_c = 60$  m/s, an axial feed of  $f_a = 0.50$  mm and a removed flank stock of  $\Delta s = 0.13$  mm. In the second pass the gear sets have been finished with the same cutting speed but with an axial feed of  $f_a = 0.37$  mm and a removed flank stock of  $\Delta s = 0.02$  mm. A grinding worm with a number of starts of  $z_0 = 1$  has been used.

One half of tested pinions is ground by a dressable vitrified bond CBN tool, the other half is ground by a state of the art vitrified bond corundum tool with 30% sintered corundum. Other process parameters and the clamping situation can be seen in Figure 3.

Geometrically all gear sets are identical concerning gear geometry deviations and surface topography. Figure 4 shows for example the gear quality of all gears after the grinding process. All gears are ground in gear quality 4 or better according to DIN 3962 (Ref. 18).

In addition to the geometrical gear properties, manufacturing related component properties of the surface zone have to be considered. Figure 5 shows residual stresses in the surface zone in axial and tangential direction for both tool variants.

In tangential direction, respectively the profile or generating direction, residual stresses  $\sigma_r$  of the CBN-ground gears are significantly higher. Due to high productivity of the CBN grains, the grinding process, especially the chip formation, induces less thermal energy to the surface. Additionally, the higher hardness of CBN grains creates higher compressive stresses which also extend deeper into

the surface zone. At the surface, gears ground with CBN have compressive residual stress of  $\sigma_t = -940$  MPa. The conventional ground only  $\sigma_t = -690$  MPa.

The surface roughness of both variants is nearly identical. Average CBN-ground gears have a surface roughness of  $R_z = 2.5 \mu\text{m}$  and the conventional ground gears of  $R_z = 2.9 \mu\text{m}$ . Referring to ISO 6336-1 the difference on load carrying capacity of the both variants concerning gear and surface quality is insignificant (Ref. 17).

**Test bed and approach.** Gear testing has been carried out at the Laboratory for Machine Tools and Production Engineering (WZL), RWTH Aachen University. The gears were tested on a 112.5 mm center distance back-to-back contact fatigue test rig at  $n_2 = 2,450$  rpm, at the pinion and with  $n_1 = 1,500$  rpm, at the input shaft. As lubricant Shell Omala F220 oil at  $T_{oil} = 90^\circ\text{C}$  was used for splash lubrication. The used back-to-back test rig, according to DIN 51354-1 (Ref. 16) and its principle, are shown in Figure 6.

Low-cycle, fatigue pitting tests were carried out with constant torque at pinion and by adhering to the FVA guideline for pitting tests (Ref. 18). These tests were conducted for each ground variant at two different torque levels of  $M_2 = 650$  Nm and  $M_2 = 750$  Nm. These torques gave peak contact stress levels of  $\sigma_p = 1,471$  MPa and  $\sigma_p = 1,578$  MPa, respectively. These values were calculated by the finite element tooth contact analysis *FE-Stirnradkette* developed by the Laboratory of Machine Tools and Production Engineering. Each test involves five tests per variant (CBN or corundum) and torque level.

**Results**

As criterion for low cycle fatigue strength a damaged surface of a single tooth of four percentage ( $V_{EZ} = 4\%$ ) is defined. In Figure 7 an example of typical pitting damages can be seen for differently ground variants at test end.

The two pictures at the top of Figure 7 show the size of the pitting at test end. All pitting of the tested pinions is located below the pitch circle, in the middle or left of the middle of the tooth flank with a similar size. Furthermore, measurements show that the pitting has similar depth and form. The difference can be found in the number of load cycles at the test end. In this example the pinion ground with dressable CBN has a number of load cycle of  $N_2 = 11,434,500$ . That is nearly 50% higher than the corundum-ground gear

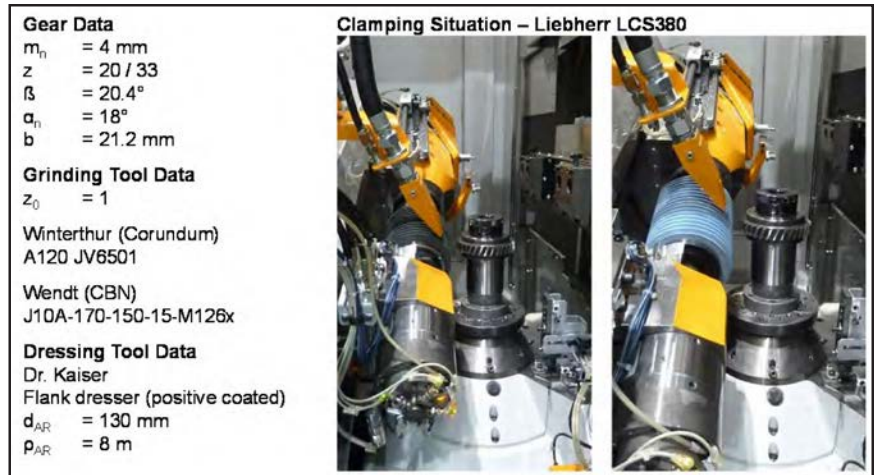

Figure 3 Gear geometry, machine tool and tool data — pitting tests.

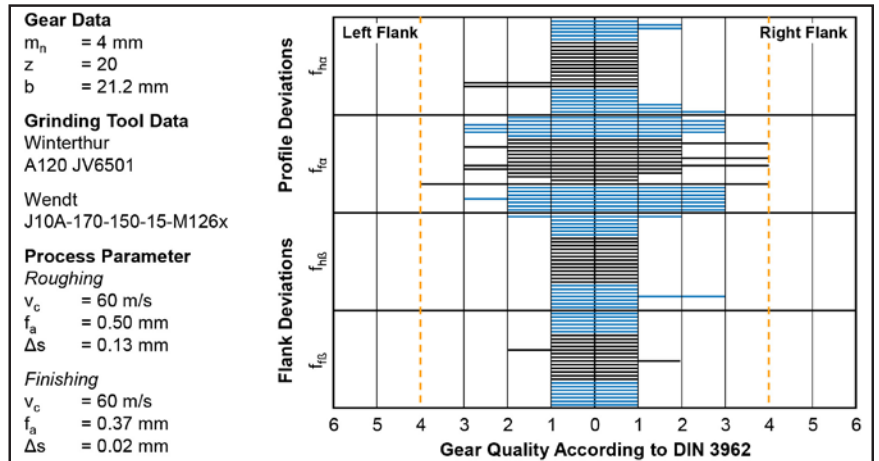

Figure 4 Gear quality of tested pinions — selected values.

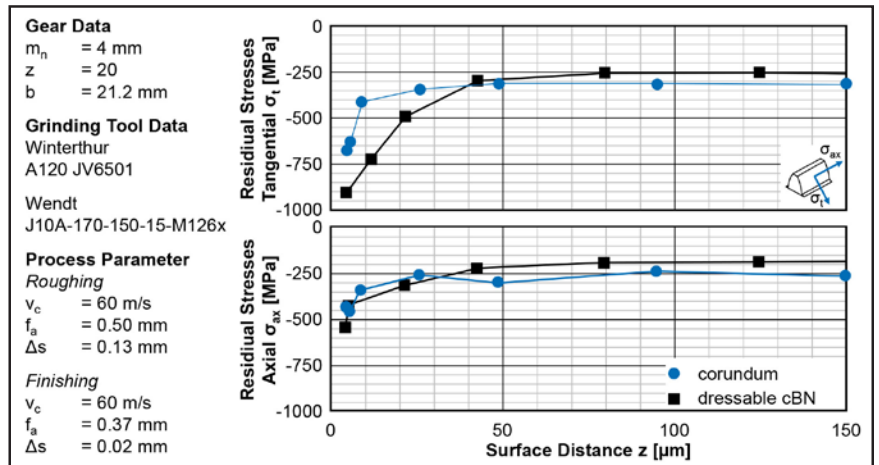

Figure 5 Comparison of residual stresses in axial and tangential direction after generating gear grinding.

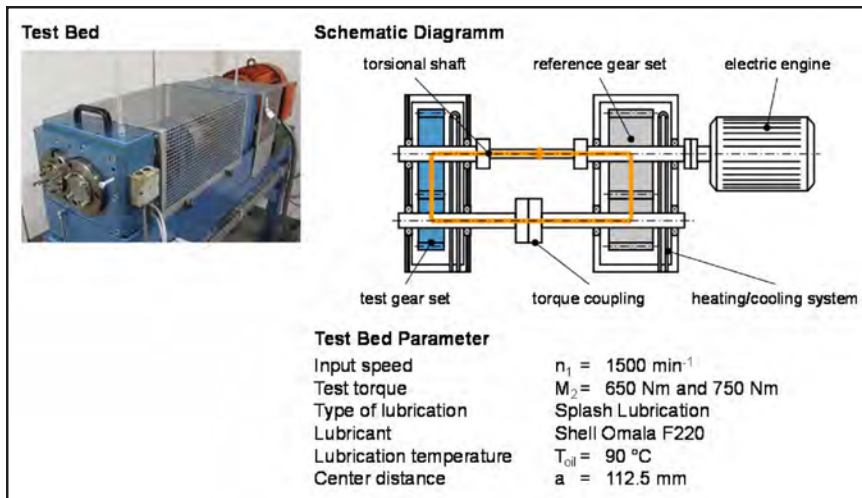

Figure 6 Back-to-back test rig according to DIN 51354-1 and testing parameters.

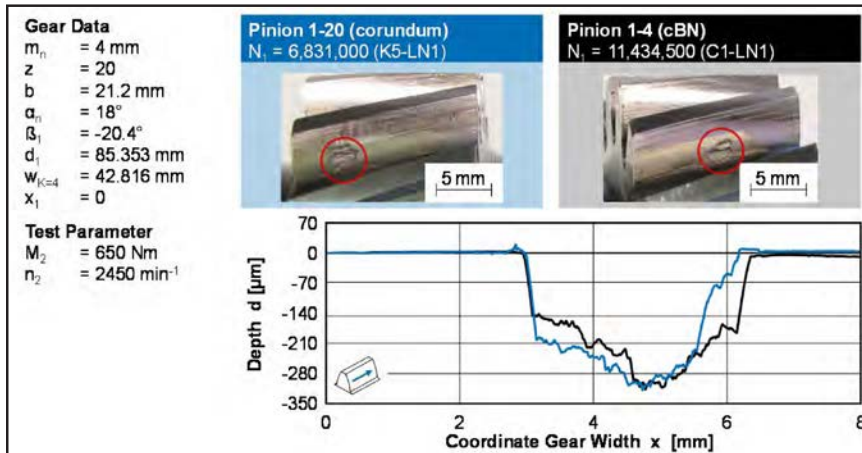

Figure 7 Comparison of pitting size and depth for different ground gears.

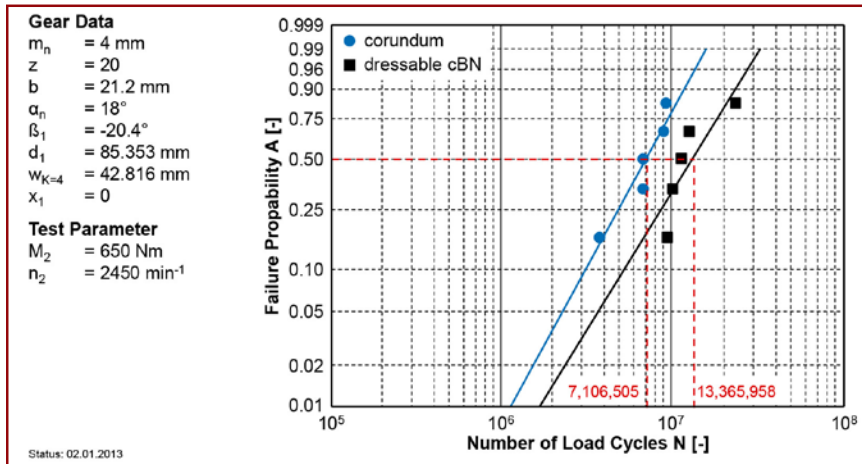

Figure 8 Comparison of failure probability, according to Weibull-Gassner for a torque of  $M_2=650 \text{ Nm}$ .

with a number of load cycles  $N_2=6,831,000$  at the same pitting size.

A complete overview of the number of reached load cycles for a torque of  $M_2=650 \text{ Nm}$  is shown in Figure 8. In the chart the failure probability over the number of load cycles reached for a torque of  $M_2=650 \text{ Nm}$  according to the probability distribution of Weibull-Gassner is shown.

A significant gap between the lines of best fit for the two ground variants can be seen. At a failure probability of  $A=0.50$  (50%), the pinions ground with dressable CBN reach, in average, a number of load cycles of  $N=13,365,958$ . The conventional ground gears only  $N=7,106,505$ . That means that by changing the tool system, a low cycle fatigue twice as high as with conventional tool systems can be achieved.

Furthermore, tests show that dressable CBN-ground gears can reach the same or higher low cycle fatigue strength at a torque level of  $M_2=750 \text{ Nm}$ , compared to the conventional-ground-gear at a torque of  $M_2=650 \text{ Nm}$ . That means a gear with the same gear geometry and approximately 15% more torque can be transferred merely by changing only the tool system in the gear grinding.

## Conclusion

Due to the higher compressive residual stresses gears ground with dressable vitrified bond CBN tools can transferee higher loads or reach a higher low cycle fatigue. Therefore, dressable CBN has a high potential in grinding gears to increase the power density.

## Performance of Vitrified Bond CBN in Generating Gear Grinding

In the following section, the performance — especially the wear behavior — of dressable CBN grinding tools will be investigated in grinding trials. Therefore, gear geometry and approach are described. Afterwards, first grinding results will be shown.

**Machine tool, workpiece geometry and grinding tools.** The objective of the performance tests is the analysis of the wear behavior of the tools with which the gear sets for pitting test were ground with. Therefore, gear geometry of the gear wheel was modified concerning its gear width to have a larger removable stock per gear.

The gear set has a module of  $m_n=4.0 \text{ mm}$  with 33 teeth, and a gear width of  $b=50.0 \text{ mm}$ . The pressure angle is  $\alpha_n=18^\circ$  and helix angle is  $\beta=20.4^\circ$ . The complete gear

geometry, the grinding and dressing tool data are shown in Figure 9.

All gears have also been soft-machined from the same material batch, 20MnCr5, and have been heat treated in one batch like the gear sets in the pitting test. The gears are case-hardened with a case-hardening depth of  $CHD_{50HV} = 1.0$  mm at the flank and a surface hardness of 60+2 HRC.

**Results**

The graphs in Figures 10 and 11 show the high technological potential of dressable vitrified bond CBN in generating gear grinding. Figure 10 shows the change of profile angle deviation for the two grinding tool systems and constant process parameters. Furthermore, Figure 11 shows changes of two ball dimension for same grinding trial.

For a cutting speed of  $v_c = 80$  m/s, an axial feed of  $f_a = 0.37$  mm in roughing and  $f_a = 0.27$  mm in finishing at one fixed shifting position of the tool, workpieces were ground until a significant wear of the tool could be detected (dashed line). For the grinding worm made of corundum, a diagonal movement according to the state of the art is used in roughing process. The complete grinding process with the dressable CBN tool and the only finishing process with corundum are performed without shifting.

With the corundum tool in one shifting position, only 10 gears can be ground until one of the defined quality criteria is crossed. In this case, the tooth width or the two-ball dimension, respectively, has changed more than  $\Delta M_k = 30$   $\mu$ m (dashed line), a change of the profile angle more than  $\Delta f_{Ha} = 15$   $\mu$ m.

For the CBN tool, both key values, the change of profile angle and two-ball dimension, are staying within the defined limits. Because no change could be detected, the trial was cancelled after grinding 100 workpiece without any traceable wear at the tool.

Summarized dressable CBN tool can be used to increase process efficiency. Due to minimal tool wear dressing time per part decreases significantly. Furthermore, the tool life time itself increases significantly.

That means tool costs per part are comparable with corundum tools (Ref. 4).



Figure 9 Gear geometry, machine tool and tool data — tool wear tests.

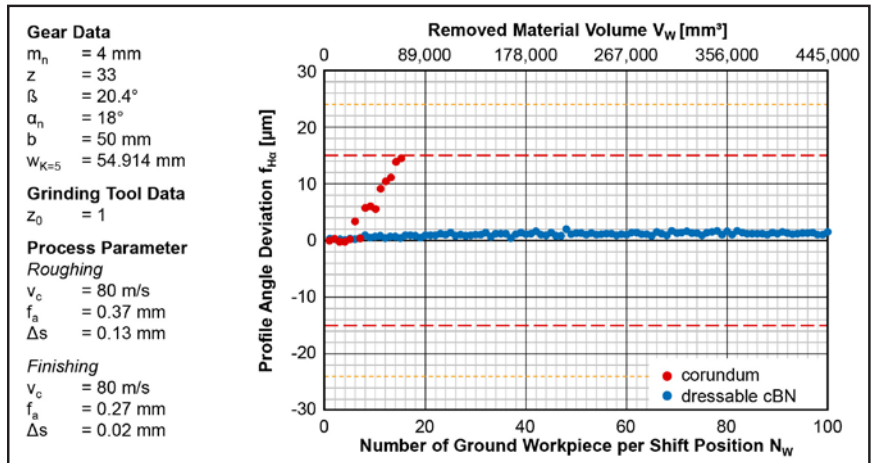

Figure 10 Change of profile angle deviation for different grinding tool systems and constant process parameter.

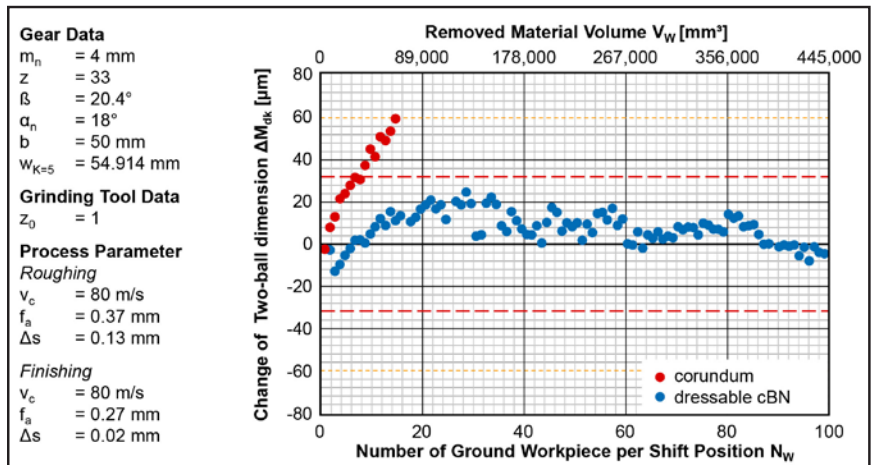

Figure 11 Change of two-ball dimension for different grinding tool systems and constant process parameter.

**Conclusions**

With its higher hardness gained through the thermal and chemical resistance of grain material dressable vitrified bond, CBN tools can handle higher tool loads with less wear and higher tool life times. Therefore, dressable CBN has a high technological potential in generating gear

grinding gears to increase the process efficiency.

**Summary and Outlook**

Dressable, vitrified-bond, CBN grinding tools combine the advantages of other common tool systems in generating gear grinding. But only a few published sci-

entific analyses of generating gear grinding with dressable CBN exist. Furthermore, there is at present limited distribution of these grinding tools.

First results from grinding investigations in this report show that dressable CBN is a highly productive cutting material due to its high specific stock removal rate. This leads to minimum tool wear and comparable tool-cost-per-part, as in the state-of-the-art process with corundum.

Despite those technological advantages, the analysis in this report shows that with dressable CBN, higher compressive residual stresses in surface zones can be reached. In particular, the influence of the grinding tool system on these manufacturing-related component properties leads to a higher, low cycle fatigue strength. In short, gears ground with dressable CBN can reach a higher number of load cycles or transferee higher torques at the same level of load cycles as conventional ground gears.

In future, all results of this report must be validated; that means grinding technology has to be tested for further process designs; e.g., number of starts, cutting speeds and feed, and for other gear geometries.

Furthermore, to decrease tool costs, manufacturing technologies of grinding worms themselves have to be optimized by tool suppliers.

In gear testing, the results have to be verified with other gear geometries. Especially, occurrence of residual stresses depending on gear geometry, tool specification and process design in grinding have to be analyzed in more detail. Therefore, a fundamental research project is planned at the Laboratory of Machine Tools and Production Engineering (WZL). 

## References

1. Klocke, F. and W. König. *Fertigungsverfahren - Schleifen, Honen, Läppen*, 4th Edition, VDI-Verlag, Düsseldorf, 2005.
2. Bausch, T. *Moderne Fahrradfertigung. Verfahren und Maschinen zur kostengünstigen Herstellung von Stirn- und Kegelhäusern mit hoher Qualität*, 3rd Edition, Expert Verlag, Renningen-Malmsheim, 2006, 12 13FTM02.
3. Brecher, C., C. Gorgels and T. Röthlingshöfer. *Manufacturing Simulation of Beveloid Gears for the Use in a General Tooth Contact Analysis Software, Production Engineering*, Volume 3, Number 1, pp.103-109, 2009.

4. Reichel, F. *Verfahrensauswahl beim Schleifen von Großverzahnungen*, Seminar "Feinbearbeitung von Zahnrädern," WZL Forum, RWTH Aachen University, 2007.
5. Sulzer, G. *Werkzeugmaschinen zum Feinbearbeiten der Zahnradflanken von vorverzahnten Zahnrädern*, European Patent EP0282046, Liebherr Verzahntechnik GmbH, Kempten, 1993.
6. Meijboom, L. *Erhöhung der Wirtschaftlichkeit beim Wälzschleifen durch Verbesserung des Zerspannvorgangs*, Dissertation, RWTH Aachen University, 1979.
7. Türich, A. *Werkzeugprofilerzeugung für das Verzahnungsschleifen*, Dissertation, University Hannover, 2002.
8. Klocke, F., C. Gorgels and J. Reimann. "Analyse des kontinuierlichen Wälzschleifens mithilfe der Durchdringungsrechnung," *50th WZL Gear Conference*, Publ.: Klocke, F.; Brecher, C., pp.14-1-14-40, 2009.
9. Klocke, F., C. Gorgels and J. Reimann. *Kontinuierliches Wälzschleifen von Verzahnungen - Softwareunterstützte Prozessoptimierung*, WB Werkstatt und Betrieb, Vol. 142, Issue 5, pp. 62-63, 2009.
10. Klocke, F., C. Gorgels and J. Reimann. "Ansatz für ein Prozesskraftmodell für das kontinuierliche Wälzschleifen von Verzahnungen," *51st WZL Gear Conference*, Publ.: Klocke, F.; Brecher, C., p.8-1-8-40, 2010.
11. Stimpel, F. "Technologische Kenngrößen für das kontinuierliche Wälzschleifen von Evolventenverzahnungen," Dissertation, University Hannover, 2009.
12. Mehr, A. "Kontinuierliches Wälzschleifen mit keramisch-gebundenen CBN Schleifscheiben," Seminar - "Feinbearbeitung von Zahnrädern," *WZL Forum*, RWTH Aachen University, 2011.
13. Denkena, B., M. Reichstein and F. Catoni. "Abriichten von CBN-Werkzeugen zum kontinuierlichen Wälzschleifen von Verzahnungen," *Industrie Diamanten Rundschau*, Issue 2, 2005.
14. Denkena, B., M. Reichstein and F. Catoni. "Kontinuierliches Wälzschleifen von Verzahnungen Mittels Keramisch Gebundener Werkzeuge aus CBN," *Industrie Diamanten Rundschau*, Issue 1, pp. 54-59, 2006.
15. Uhlmann, E. and L. Hochschild. "Tool Optimization for High-Speed Grinding," *Production Engineering*, Volume 1, Number 1, p. 103-109, 2013.
16. DIN 51354:1990 - *Testing of lubricants; FZG gear test rig; general working principles. ISO 6336-2:2006 - Calculation of load capacity of spur and helical gears, Part 2; Calculation of surface durability (pitting)*.
17. DIN 3962:1978 - *Tolerances for Cylindrical Gear Teeth - Tolerances for Deviations of Individual Parameters*.
18. Höhn, B., P. Oster and U. Schedl. "Pittingtest," FVA-Beitrag zum Forschungsvorhaben 2 IV, Forschungsvereinigung Antriebstechnik e.V., Frankfurt, 1997.
19. DIN 3960:1987. *Begriffe und Bestimmungsgrößen für Stirnräder (Zylinderräder) und Stirnradpaare (Zylinderradpaare) mit Evolventenverzahnung*.
20. Schlattmeier, H. "Diskontinuierliches Zahnflankenprofilschleifen mit Korund," Dissertation, RWTH Aachen University, 2003.
21. Gorgels, C., F. Klocke, G. Martel, W. Michel, A. Mundt, M. Queins, J. Reimann, G. Roobaert, A. Stuckenberg and R. Thalacker. *Serienproduktion von Großbauteilen, Integrative Produktionstechnik für Hochlohnländer*, Publ., Aachener Werkzeugmaschinen Kolloquium, Brecher, Klocke, G. Schuh and R. Schmitt, Apprimus Verlag, Aachen, 2011.

**Dr. Andreas Mehr** studied mechanical engineering on the Universität Karlsruhe (TH), Germany. Afterwards he worked for five years as a scientist in the manufacturing and materials technology group at the wbk Institute of Production Science of the Universität Karlsruhe (TH). The topic of his PhD was "Hard Precision Machining of Gears with Crystalline Diamond Coated Tools by Gear Shaping." Since 2004, Andreas has worked at Liebherr-Verzahntechnik GmbH in Kempten, Germany. At Liebherr he is responsible for the technology development of gear shaping and gear grinding.



**Dr. Klaus Finkenwirth** joined Liebherr-Verzahntechnik GmbH in 1991. Since 2004 he is the responsible managing director for production, after sales, and technology. Finkenwirth studied machine tool design in Munich and graduated in Erlangen on the subject "Design for Production with CAD Systems."



**Prof. Dr.-Ing. Dr.-Ing. E.h. Dr. h.c. Dr. h.c. Fritz Klocke** has since 1995 served as director of the Chair of Manufacturing Technology at the Laboratory for Machine Tools and Production Engineering (WZL) of RWTH Aachen University, as well as director of the Fraunhofer Institute for Production Technology. He was the Dean of the Faculty for Mechanical Engineering in 2001 and 2002. He has three honorary Ph.D. degrees from the University of Hannover, by the University of Thessaloniki and by the Keio University. His work for production engineering was rewarded with several awards, e.g. Fraunhofer Medal in 2010, Eli Whitney Productivity Award (SME) in 2014.



**Dr. Andreas Mehr** studied mechanical engineering on the Universität Karlsruhe (TH), Germany. Afterwards he worked for five years as a scientist in the manufacturing and materials technology group at the wbk Institute of Production Science of the Universität Karlsruhe (TH). The topic of his PhD was "Hard Precision Machining of Gears with Crystalline Diamond Coated Tools by Gear Shaping." Since 2004, Andreas has worked at Liebherr-Verzahntechnik GmbH in Kempten, Germany. At Liebherr he is responsible for the technology development of gear shaping and gear grinding.

**Dipl.-Ing. Jan Reimann** studied mechanical engineering at RWTH Aachen University with a focus on production engineering. In December 2008 he graduated and became a scientific research assistant in the gear department of the Laboratory of Machine Tools and Production Engineering (WZL). His research is focusing on gear hard finishing, especially generating gear grinding, and manufacturing related properties. Since January 2014 he is the team leader of the gear manufacturing group within the gear department.



# Practical Considerations for the Use of Double-Flank Testing for the Manufacturing Control of Gearing - Part II

Ernie Reiter and Fred Eberle

Part I of this paper, which appeared in the January/February issue of Gear Technology, described the theory behind double-flank composite inspection. It detailed the apparatus used, the various measurements that can be achieved using it, the calculations involved and their interpretation. The concluding Part II presents a discussion of the practical application of double-flank composite inspection—especially for large-volume operations. It also addresses statistical techniques that can be used in conjunction with double-flank composite inspection, as well as an in-depth analysis of gage R&R for this technique.

## Statistical Techniques for Double-Flank Inspection

Statistical process metrics are very important to production gears made in large quantities. Unlike small sample runs where nearly every part would be inspected, it would be impractical to do so for high-volume generated or molded gears. As a result, only a few samples are measured at a logical predetermined frequency to monitor the process in time. The primary goals of statistical techniques will determine if the process is—or continues to be—stable without anomalies and to ensure that the manufacturing process is capable. If these are satisfied, then there is confidence that the part quality is also good.

Determining the process capability of total composite variation (error/TCE), tooth-to-tooth variation (error/TTE), and tight mesh center distance (TMCD) or test radius (TR), using double-flank composite inspection (DFCI) is a practical and economic way to determine if a gear manufacturing process is stable and acceptable. This is true for all types of gears, but particularly true for high-volume-production gears such as those molded by plastic injection molding or powder metal processes.

Using DFCI data for statistical analysis can greatly aid in optimizing gear tools during the debugging phase of the initial manufacturing process. It is also an effective means of maintaining ongoing and real-time process control. This section provides an illustrative case study of the use of these statistical techniques during the development stage of an insert-molded plastic gear that is molded on to a steel shaft. The techniques presented are especially suited for initial and ongoing statistical analysis in a high-volume manufacturing environment. In addition, this paper will also discuss two ways of executing a study to validate the accuracy of the measurement system itself.

## A Case Study of Statistical Techniques during Gear Development

The gear materials used, the type of injection gating, the uniformity of wall sections, and thermal mold flow behavior all have a significant impact on the resultant geometry and overall quality characteristics of a plastic-injection-molded gear. Experienced gear molders understand these issues and incorporate counter measures to minimize the impact of known causes of variability. However, after the gear molding tool has its initial pilot run and a higher level of gear quality is still required, the inserts and

other critical aspects of the mold may need fine-tuning in order to bring select qualities into conformance with design intent. In every type of gear manufacturing operation, specific tooling and process adjustments can be effectively made only from a stable process. When there is a lack of stability, making tooling adjustments is analogous to trying to hit a moving target—rarely successful in tuning gear tools.

In a total composite error case study of a new tool for an insert-molded plastic gear (Fig. 8), all of the samples measured from the two cavity molds were comfortably within the design tolerance of 0.118 mm. Without looking at the potential process capability, one may have been satisfied with the results, and the tooling could have been approved for production. However, it was discovered using a probability plot (Fig. 9a) that the probability statistic (i.e., the “p-value”) at a 95 percent confidence interval for Cavity 1 is 0.019, while for Cavity 2 the value is 0.817.



**Figure 8** Over-molded plastic gear on a metal shaft for the case study (all images courtesy of Hi-Lex Controls Inc.).

Note that in creating this chart the null hypothesis of the test is as follows: variation in the sample is normal and hence random in nature; a high probability statistic result means that the hypothesis is more likely correct, while a low result means that the hypothesis is less likely to be so.

The high p-value significance test of Cavity 2 (i.e.,  $0.817 > \alpha$  value of 0.05 at a 95 percent confidence interval) indicates that the data in Cavity 2 is normally distributed and has random process variation. The low p-value of Cavity 1 shows just the opposite; i.e., that there must be an assignable cause for the variation. We can also see this visually (Fig. 9a) from the variation and scatter within the hyperbolic confidence interval lines of Cavity 1. Note that data approximating normal-

ity will have a tendency towards forming a straight line in a probability chart.

In this case study the mold was alerted that variation coming from Cavity 1 was unstable, with an undetermined but assignable cause. Further investigation revealed that the metal shaft being over-molded onto the gear was hanging up slightly in the mold and causing unpredictable distortions of the gear in Cavity 1. After correction, the revised probability statistic was re-evaluated and the acceptable result is shown (Fig. 9b). Note that after the fix, the resulting overall Cavity 1 TCE standard deviation was lowered to 0.00518 mm—a reduction by over 55 percent from the original trial. The resulting reduction in variability—even with this small number of samples—gives statistical confidence that the tool and process are greatly improved and should produce in-specification parts for the long-term. Without this statistical analysis, at some future point during production a vexing quality problem may have surfaced requiring 100 percent inspection of this characteristic. Indeed, the true root cause may never have been found if a probability plot had not been generated.

With the special cause of molding variation eliminated, a capability analysis can now be done to determine the strength of the manufacturing process. However, it must be noted that until the total composite error data has a reasonable conformance or approximation of normality, or until a much larger sample of data is taken, a capability study would not be appropriate; it would lack sufficient statistical confidence and accuracy. The revised probability plot (Fig. 9b) shows that the p-value for Cavity 1, with  $p\text{-value} > 0.05$ , meets the criteria of approximating normality and indicates that the process is stable. If normality exists in small datasets of 30 to 60 samples, capability analysis can be shown to be accurate within its confidence interval. But if the data does not approximate normality (i.e.,  $p\text{-value} < 0.05$ ), more data may overcome this condition.

Therefore, now that the process is under control, a snapshot of process capability can be taken. A Cpk (capability performance) analysis (Fig. 10) can be done. In performing this analysis for total composite error, a lower bound is established at the lower specification limit of 0.0, while the upper specification limit is set at 0.118 mm. The lower-bound method is used instead of a lower specification limit because total

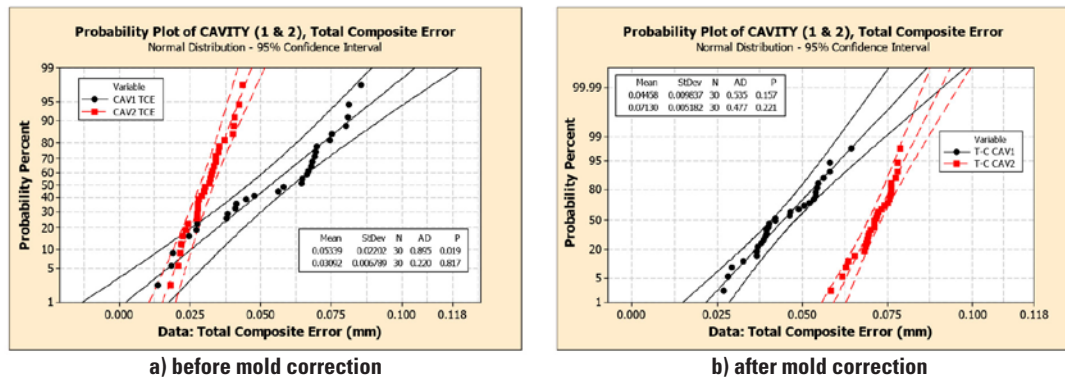

Figure 9 Probability plot for the case study plastic gear:

composite error (as well as tooth-to-tooth error) is always a one-sided, maximum value. A value of less than 0.0 is impossible to achieve. Hence it is only appropriate to calculate capability for both Cpk and Ppk (performance capability) against the upper specification limit.

Furthermore, the mean line on the chart in Figure 10 is only a visual cue for process drift. By showing an optional mean line at the center of the total composite error specification, the analyst can visually see an orientation of shift or drift in future process measurements.

The capability snapshot analysis shows a Cpk of 2.97 with a 0.118 mm upper-specification limit for the gear's total composite error. A minimum Cpk of 2.0 is usually desired for initial and unknown, long-term process data in order to theoretically allow for a 1.5 Sigma drift resulting in a Ppk of 1.67. Based on that assumption, and the data presented here, it is reasonable at some future point to consider reducing the specified tolerance to 0.095 mm, resulting in a Cpk of 2.0 if a stable process and more data bear that out.

NOTE: The Cpk is based only on one snapshot of the process of 30 data points, i.e. — one sub-group. Thus this data represents a preliminary screening test of the process at one point in time. Calculation of the potential (within) capability is a special case for a sub-group = 1, and is done

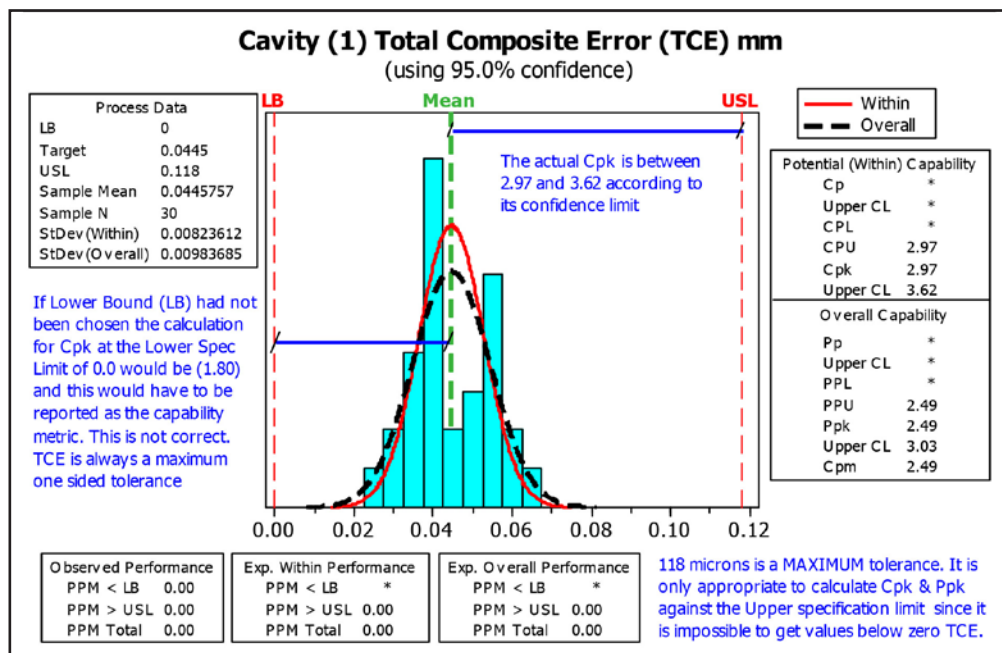

Figure 10 Process capability plot for the case study plastic gear.

with an estimate of standard deviation made with a moving range equation (Ref. 2). Also,  $Ppk$  — the long-term estimate of process capability — in this example is determined by inferring a percentage of process drift that is purely theoretical; it is not based on any hard data from this gear. Thus, it is important to understand that in order to truly measure your process, more data must be taken over time — e.g., set-ups, shifts, lots or whatever the case may be — in order to properly assess the condition of the part.

Based on this first production run data, it would be useful to evaluate five to ten sub-groups per-lot of future data. When there are three-to-five production lots established, the re-calculated process capability will lend much more confidence and understanding of the long-term capability of the tool, process, and true quality level of the manufactured gear. A probability distribution plot of total composite error (TCE) (Fig. 11) can be very helpful in predicting the range of the tolerance that the established process will use. It provides more insight into how reliable and robust the actual process is — and is expected to be — in the future. In this case it is predicted that only four percent of TCE measurements in the future will be greater than 0.059 mm or 50 percent of the TCE tolerance of 0.118 mm.

Please note: the 0.059 value is arbitrarily chosen.

With a process in statistical control, total composite and tooth-to-tooth variation will conform to a normal distribution. However, if normality is not present, a look at the histogram will reveal clues as to what shape of parametric or non-parametric distribution the data conforms to. If necessary, other standard statistical tools or transformation techniques are required to normalize the data or create a non-parametric predictive model of the process. It can be shown that as more measurement data is accumulated, the normality requirement becomes less and less important in determining process capability for the metrics described in this paper.

A question that often arises is whether capability requirements with double-flank inspection are necessary if parts are in specification. For high-volume products the customer must

be certain that the gear manufacturer is capable of supplying parts within specification, shipment after shipment, and that the manufacturer's process is robust. Most gear purchasers can only verify small quantities of gears using their receiving inspection procedures, yet the consequences of quality issues may be technically and economically catastrophic. In one case study, a high-volume gear sold for \$1 and was assembled into an automotive device that sold for \$120. The sub-assembly replacement cost of a defective gear in the manufacturing plant was \$26, but escalated to over \$200 in the field. The economic damage to a customer can be exponentially greater due to the value-added assembly. Process control and capability measurement are crucial in long-term product quality and customer success. Responsibility for this success falls not only on the gear manufacturer, but also the gear designer, who has to ensure that product specifications are reasonable for the intended manufacturing process deployed.

### Statistics for ongoing, double-flank composite inspection.

The following documentation applies to molding plastic gears; however, many of the issues described are transferrable to any gear manufacturing processes.

When large quantities of gears need to be produced, it is essential to know where and when quality characteristics related to gear performance occur, and how to use this information to improve your process. Certain statistical analyses are effective at pointing to causes of variation.

For example, assignable causes from DFCI data could indicate:

- A shift in tooth size (evaluate with tight mesh center distance)
- A change in eccentricity or tooth profile conformance (evaluate with total composite error)
- A change in nicks, burrs, handling damage or tooth form (evaluate with tooth-to-tooth composite error)

### Applying ongoing statistics to total composite error.

Probability curves and capability metrics are useful tools to analyze total composite error. The probability curve opens a window of understanding on the type of variation present in double-flank roll data. Similarly, it is useful for determining if the data is stable and suitable for making potential capability models and conducting certain hypothesis tests. If the probability analysis is acceptable, then a capability study can be prepared specifically to:

- Assess the potential strength (robustness) of a process at a specific point or points in time
- Predict the future potential of a process to create a values within design limits using meaningful metrics
- Identify improvement opportunities in the tooling or process by reducing or possibly eliminating sources of variability (Ref. 2).

Ongoing, TCE capability evaluation provides meaningful insight into the robustness of the products being made and confidence in the ability to consistently make parts to design intent.

## Applying Ongoing Statistics to Tooth-to-Tooth Composite Error

Tooth-to-tooth error is best scrutinized from real-time tracking on an Xbar-R (average and range) chart for data in sub-groups  $\leq 8$ , or an Xbar-S (average and standard deviation) chart for sub-groups  $> 9$ . For these larger sub-sets, the range in an Xbar-S chart is a much better statistic to estimate distributions of the sub-groups.

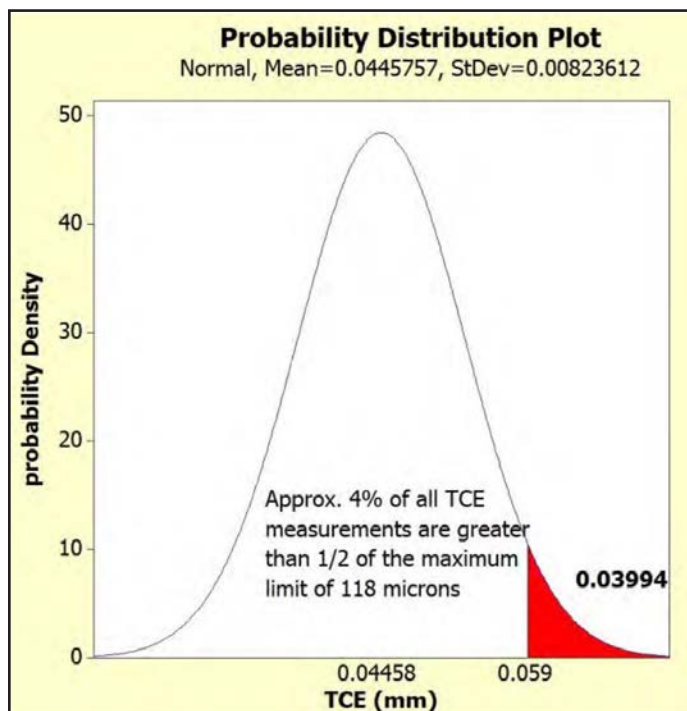

Figure 11 Probability distribution plot.



An Xbar-S chart is usually the most appropriate choice to detect changes in tooth-to-tooth error for molded gears with a reasonable sensitivity. A real-time, in-process TTE control chart is highly recommended because changes in tooth-to-tooth error are generally the first indicator of a change in the manufacturing process.

The change in tooth-to-tooth error, particularly in injection molding — but also in powder metal gearing, fine-blanking and wrought gear cutting and grinding — will signal potential handling damage, such as burrs (or flash); nicks; part ejection issues; dirty or worn tooling; and other surface irregularities. When these special-cause events start to occur, the TCE will not have nearly as much sensitivity as tooth-to-tooth error. TTE will have more sensitivity in flagging these events over TCE due to its smaller tolerance.

The goal in control charting is to capture any degradation in gear quality and resolve it before the manufacturing process trends out of control. In addition to in-process verification, control charts can be a particularly important tool to validate set-up and process conditions just prior to approving large production runs. The data does not need to be normal, but if the process is not stable, any chaotic behavior will be graphically evident and the control limits may not be valid.

When using control charting, tooth-to-tooth data, it is important to:

- Take at least 100 data points to ensure that the control limits are precise, or else consider the results preliminary.
- Evaluate the data in time order to identify trends as they occur; control charting after production precludes any possibility that a process correction could be made in time to save or improve the production run.
- Select an appropriate number of measurements for individual sub-groups using the following equation:

$$N = \left[ \frac{(N_{\alpha/2} + N_{\beta})}{D} \right]^2 \quad (24a)$$

where:

$N$  is the number of measurements needed for an individual sub-group

$N_{\alpha/2}$  is the number of standard deviations above zero in a normal distribution —  $\pm 3$  Sigma is commonly used.

$N_{\beta}$  is based on a percentage probability that the analysis will detect a shift in standard deviation between sub-groups (note that for an 80 percent probability,  $N_{\beta} = 0.84$ )

$\sigma$  is the historical standard deviation established for the process; this parameter must be historical to a particular tool, process or cavity of interest; the value is important and should be appropriately established.

$D$  is the sensitivity parameter; i.e., the amount of change in tooth-to-tooth error that is to be detected.

For example, given a historical tooth-to-tooth error standard deviation of 0.0045 mm, and an 80 percent probability that a shift of standard deviation can

be detected within 0.0055 mm, determine an appropriate number of measurements needed for individual control chart sub-groups using  $\pm 3$  Sigma. Using equation 24 —

$$N = \left[ \frac{(3 + 0.84) 0.0045}{0.0055} \right]^2 = 9.87 \quad (24b)$$

Therefore a minimum of 10 measurements-per-sub-group should be used, and an Xbar-S chart (Fig. 12) is most appropriate. Over the course of 100 measurements (Fig. 12) the control chart shows that the process is consistent and predictable, with only random variation present. A look at the sub-group means in the top chart gives a good reading of where the process is and the average sub-group, tooth-to-tooth error spread between sub-groups. In the lower chart, even though there are some numerical differences between sub-group standard deviations, all standard deviations fall within the calculated control limits.

*NOTE: Never consider the calculated control limits as relative to component design specifications — they are not related. The upper- and lower-control limits are based only on the measured sub-group data. The expected or predicted variation in the process is calculated as 3 Sigma above and below the average sub-group standard deviation line. The control limits are used to determine if any sub-group behaves differently than expected. The control chart does not tell us if the process is capable within the specified tolerances; it only tells us if the process is trending or stable within the calculated control limits. Capability relative to its tolerance specification is a separate statistical check, as previously discussed.*

**Applying ongoing statistics to tight mesh center distance or test radius.** Tight mesh center distance (or test radius for the purpose of this section) are often regarded to be significant product characteristics on gear drawings. For example, in injection molding of plastic gears the tight mesh center distance data measured during double-flank inspection is affected by cavity pack pressure. Higher pack pressures generally increase tooth size and reduce total composite error. Lower cavity pressures increase total composite error and reduce gear tooth size.

Even though the tight mesh center distance results include the effects of total composite error and tooth thickness, it is some-

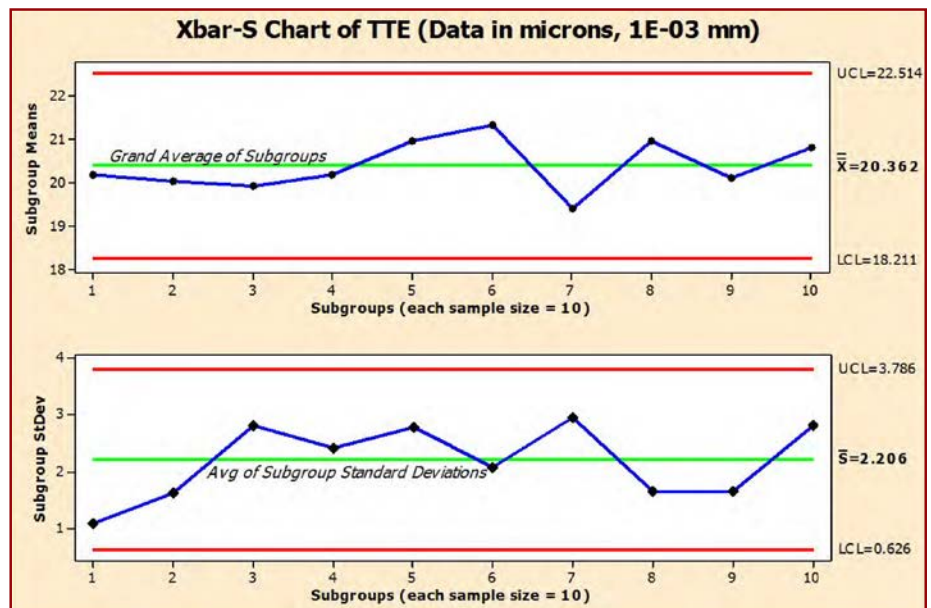

Figure 12 Typical control chart of in-process tooth-to-tooth error data.

times problematic to deal with this parameter in a statistical manner.

If a capability requirement is specified on tight mesh center distance, the procedure for applying capability is extremely important. This is because an individual gear does not have a single parameter of tight mesh center distance. As an example, the gear measured in Figure 3 has a maximum and minimum tight mesh center distance reported as 23.115 and 23.093 mm, respectively, resulting in a mean value of 23.104 mm. For the individual part to be in tolerance, every rotational position of the gear must be in specification when rolled against its master. Therefore if only a single value for tight mesh center distance is assigned to an individual part (mean value, for example), there are no functional specification limits to calculate its capability.

In order to calculate Cpk or Ppk on tight mesh center distance, two separate capability studies must be performed (Figs. 13–14). The first study uses the minimum TMCD data in comparison to the minimum specification value. By setting an upper-bound on the maximum TMCD specification, the capability metric is guaranteed to be taken against the lower specification value only. The second half of the study uses the maximum TMCD data against the maximum specification value. This time the minimum TMCD specification value is selected as a lower-bound to guarantee that the capability metric is only taken against the maximum specification value. The actual calculated Cpk or Ppk will be the lesser of the two reported values; in (Figs. 13 and 14) the actual TMCD capability Cpk = 0.57.

*NOTE: Using the upper- and lower-bound method reports a Cpk or Ppk as being towards the desired specification only. Had the upper-bound method not been used (Fig. 13), the minimum tight mesh center distance, Cpk, would have been incorrectly reported towards the upper specification, since the data is closer to the upper specification limit. In (Fig. 14) the use of the lower-bound made no difference to the final result since the actual data is in fact closer to the upper specification.*

From the figures it can be seen that although the minimum TMCD is capable, the maximum TMCD is not; hence, a process or tooling shift is needed. A subsequent reduction in the tooth thickness (in this case by 13 microns smaller) resulted in shifting both the maximum and minimum tight mesh center distance results lower by 18 microns towards the lower specification limit. This centering shift results in an improved overall Cpk of 3.46.

In this case a satisfactory result was obtained with only a shift in the tooth thickness. In some instances it is possible that, even using the best tooling and processing analysis, a further improvement in the capability index may not be possible. In such cases it may be necessary to question the suitability of the tight mesh center distance tolerance and the parameters that make up that tolerance (i.e., tooth thickness variation and total composite variation). If the total composite error is in statistical control, one would have to conclude that the tooth thickness variation itself is the issue that must be reviewed.

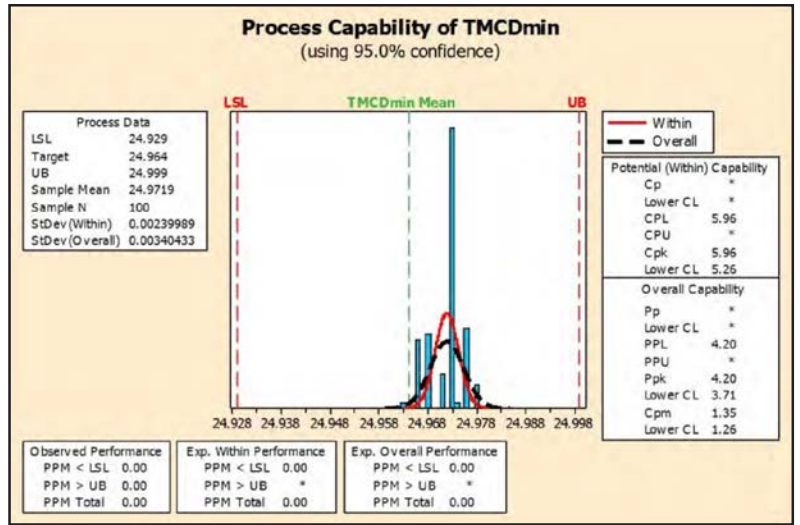

Figure 13 Minimum tight mesh center distance capability study.

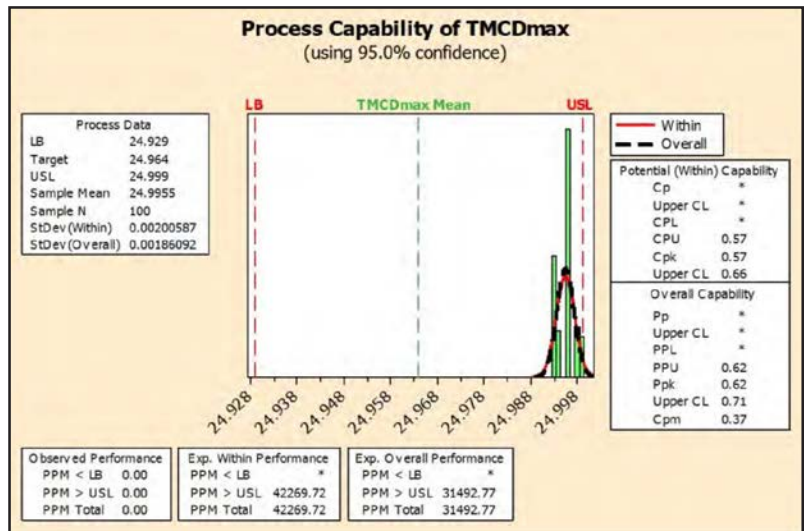

Figure 14 Maximum tight mesh center distance capability study.

## Measurement System Analysis of Double-Flank Composite Inspection

The most common method of measurement system analysis used in manufacturing at this time is gage repeatability and reproducibility (gage R&R). There are inherent issues in double-flank testing due to the dynamic function of the gage, which typically results in higher gage R&R results than what is typical for other static-type measurements. As such, gage R&R may not be the most suitable approach for measurement system analysis when it comes to double-flank composite inspection practices. Instead, uncertainty analysis may be a more fitting approach for measurement system analysis, as will be further explained.

**Gage R&R and double-flank composite inspection.** By definition, gage R&R by ANOVA method (*Editor's Note: analysis of variance—ANOVA—is a collection of statistical models used to analyze the differences between group means and their associated procedures, such as "variation" among and between groups*) is the amount of measurement variation introduced by a measurement system that consists of the measuring instrument itself and the individuals using the instrument. A gage R&R study quantifies three things (Ref. 2):

1. Repeatability: variation from the measurement instrument

2. Reproducibility: variation from the individuals using the instrument
3. Overall gage R&R: the combined effect of 1 and 2

The gage R&R study determines how much of the observed process is due to measurement system variation. It breaks down the overall variation into its part-to-part repeatability and reproducibility components. The total gage R&R is the sum of all the study variation minus the actual dimensional variation between parts. The goal is that 90 percent or more of measured variation be due to the actual dimensional differences in the study parts; it is desirable that only 10 percent of the variation be attributed to the repeatability of the gage and appraisers.

The two-way ANOVA table lists the following sources of variability (Fig. 15):

- Part: Represents the variability in measurements across different parts. The goal is that all the variation be identified as the actual size differences between parts.
- Operator: Represents the variability in measurements between inspectors.
- Operator \* Part: Represents any potential interactions between these two main effects.

The overall gage R&R is normally expressed as a percentage of the specified tolerance for the attribute being studied. A value of 20 percent or less gage R&R is considered acceptable in most cases.

**Gage R&R case study results.** The following is a real example gage R&R on total composite error that was carefully performed by three highly trained appraisers on five identical, unfilled acetal plastic gears tested against a high-quality master gear. The equipment, electronic controls and software used are considered to be some of the very best the industry offers. A well-made, unfilled acetal gear was chosen because acetal is one of the most common and accurately molded plastic gear materials used in industry.

The analysis (Fig. 15) shows that the total gage R&R fails at the 80.3 percent level, and that part measurement repeatability is the primary contributor with over 80 percent of the total variation contribution, as compared to under 20 percent coming from part-to-part variation.

As stated previously, according to the ANOVA method, repeatability is related to the measuring instrument. This result, however, seems illogical given the quality of the instrument employed and the extremes which the study went to in order to avoid variation in the instrument and measurement process. These methods included motorized rotation of the gearing, computerized data collection and high-quality part holding devices to ensure centering of the part on the measurement mandrel.

A very revealing value shown in the ANOVA table (Fig. 15) is the number of dis-

tinct categories value of 1. For a measuring system analysis with five parts, a value of five distinct categories is typical. A value of 1 would mean that the measurement system is of no value in evaluating the process, since one part cannot be statistically distinguished from another part.

Furthermore, in the Xbar chart (appraiser section, Fig. 15) it is shown that there is variation within the same part from appraiser to appraiser, while the “Part \* Appraiser Interaction” curve shows in a different way how far apart the appraiser variation is from each other. Since the p-value for the potential Part \* Operator interaction is 0.413, and hence greater than 0.25, we conclude that there is an interaction between part and appraiser, and that this statistic will be included in the error calculation and not be dropped from the gage R&R model (Ref. 3). This interaction, as reported by the ANOVA method, again seems illogical given the extreme control exercised in taking the measurements and the training and experience of the operators involved.

Further consideration of this issue was given by virtue of observation over many different types of gears including plastic, powder metal, fine blanked, and wrought cut gearing. The question of what effect can arise from minor surface imperfections in a gage R&R was considered. Surface-related issues that could affect measurements like dirt, cutting fluids, burrs, nicks, parting line flash and wear may have an impact on results from one

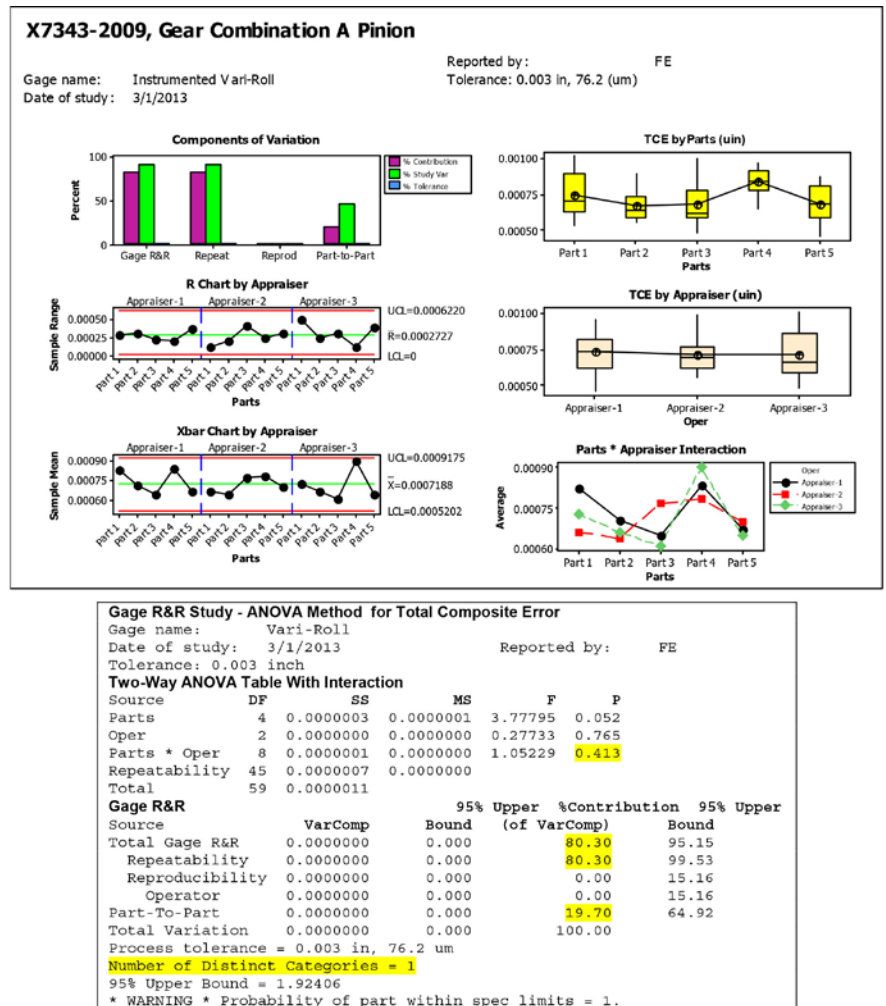

Figure 15 Gage R&R charts and results.

reading to the next. Double-flank contact has a combination of rolling and sliding action under contact pressure that may further influence these characteristics. Further consideration of the ANOVA method shows that it is very sensitive to changes in the part itself, yet those changes are incorrectly reported as variation from the measuring instrument.

To quantify this effect, a fresh part of the type used in the gage R&R study was rolled 100 consecutive times in double-flank tests by one operator to evaluate total composite error. The results for this plastic acetal gear are shown (Fig. 16).

The upper chart is a chronological run chart reporting total composite error on a clean, un-lubricated plastic acetal gear, with a precision master in successive rolls. The lower chart is a moving range chart where two data points from the upper chart are used to calculate the moving range (for information only). The range data shows that the first four rolls are stable and repeatable, but beyond that the data is not stable. Twenty-four out of 50 sub-groups (48 percent) are out of control on the Xbar chart, which is a conclusive result given that chance alone would have only explained for 0.7 percent of the total sub-groups being out of control. In the first 10 rolls, there is a 30 percent variation in the total composite error result. By roll 42 a noticeable change occurs in the total composite error, and by roll 58 there is a permanent shift and increase in the result. Something is changing with repeated rolls!

This observation does not necessarily mean that the double-flank composite inspection equipment is not repeatable. Since the control chart data is displayed in time order, the conclusion is that the gear has distinctly changed after the fourth roll, continues to change thereafter, and is likely responsible for nearly all of the repeatability error results according to the analysis of variants method.

Hence it can be concluded that 100 consecutive rolls of the same gear on a high-end, well- controlled piece of double-flank inspection equipment were not repeatable since the part itself had changed. It can be further concluded that the gage R&R method in this case does not accurately predict the actual measurement system performance, since the ANOVA mathematics assume that the part does not change.

**Further assignable causes of the poor gage R&R.** Subjecting gearing to a classical AIAG gage R&R analysis has always been reported to be very difficult, if not impossible. This case study may be the first time in-depth research has been reported to determine why it is so difficult. The following assignable causes may not fully capture all related issues that affect gage R&Rs, but are intended to demonstrate what was observed in this example.

**Static measurements:** Gage R&Rs are most successful with static measurements. An example would be of a gage that measures specific shaft diameters where the accuracy and bias of the instrument is calibrated to a master value on equipment with 10X the accuracy of the measuring instrument to be used.

**Dynamic measurement:** DFCI is a dynamic measurement system and dynamic systems, whether electronic or mechanical (or both), have characteristics

that can have a critical impact on the gage R&R results. Some of these characteristics include:

**Composite effect of the measurement:** Rolling a master and a work gear is not just measuring one dimension, even though the result may be expressed as a single value. The result has many influences, often compounding on each other.

**Infinite number of readings:** The composite test result is not a single value but is a dataset made up of potentially hundreds or thousands of data points. Under a dynamic data collection method the algorithms that are used to identify and report on the data may not necessarily provide an identical scan location every time the part is rolled.

**Hunting teeth:** Hunting tooth combinations will ensure that it is unlikely that the same master and test gear flank sets will be repeated on any roll without indexing the roll set every time.

**Surface imperfections:** Surface imperfections will skew the inspection data very quickly, regardless of whether they wear-off or wear-in. The data may show composite error variations roll-to-roll as burrs, flash or irregularities change.

**Cleanliness:** Since the measurements are evaluated in micro-inches or micrometers that are very small units of measure, laboratory control and cleanliness methods are critical. If the debris is moved from one roll to the next, the result will be an inconsistent reading

**Running-in/wear:** DFCI is usually done without lubrication and, depending on the test pressures and materials used, contact may induce run-in or wear characteristics on a gear.

**Sliding vs. rolling:** Minute variations in specific sliding from tooth to tooth may cause variances. Higher sliding action, as is the case in crossed-axis helical gears, may result in slip stick conditions during meshing that could result in more reading instability.

**Speed of rolling and data acquisition:** Higher rolling speeds during testing can impact results — both for mechanical and electronic systems. Rolling speed must take into account the natural frequency response of the tester.

**Automated acquisition systems:** For motorized rolling and computerized, electronic data acquisition, a minimum of 20 data points-per-tooth are recommended. More data points are

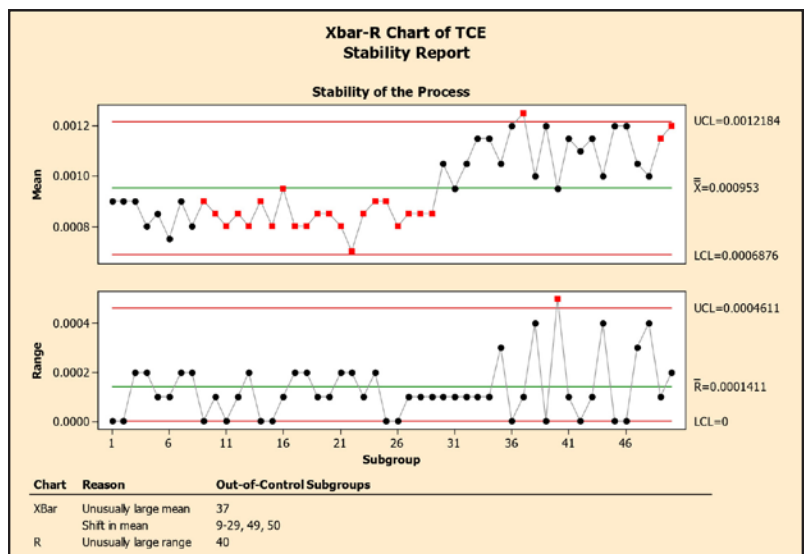

Figure 16 Data control chart of the same acetal plastic gear rolled tested 100 times on the double-flank tester.

always encouraged, but may then produce different results; the computer must be able to process all information at a fast enough speed to obtain an accurate result. In addition, where and how consistently the software and electronics take probe readings is a factor. Variation from where the initial to final points are taken on a specific tooth could impact results.

**Rolling resistance:** Rolling resistance of various test gears on the mandrel can induce increased torque resistance, resulting in increased gear separation forces that may affect measurement results.

**Conclusions related to Gage R&R evaluation in DFCI.** Due to the nature of the dynamic response and composite character of TCE, TTE, tight mesh center distance and test radius, an ANOVA analysis of DFCI data may not be appropriate. The sensitivity of the ANOVA mathematics, a requirement for multiple rolls on a single part and all the potential influences of variation, work to defeat this type of analysis. The analysis is often unsuccessful in obtaining a meaningful gage R&R statistic.

Which begs the question: What is the ultimate goal in evaluating the measurement system? The obvious answer: To determine the uncertainty in the measuring system for the purpose of quantifying the true, exact value of the object being measured. Therefore an alternate technique to gage R&R is offered, using certainty analysis for assessing the accuracy of the dynamic DFCI measurement system.

**Certainty analysis of the DFCI system.** Uncertainty of measurement is defined as: The difference between an actual and the predicted measured value. In understanding measurement systems analysis, the concern is not only with the measured value, but also the error associated with its measurement. Any unknown measurement deviation that departs from the true value is a source of uncertainty. Uncertainty analysis is a predictive technique used to quantify systemic error that is always inherent within the total measurement system.

Building a predictive model of uncertainty for double-flank composite inspection has its own unique forms and practices. The following suggests a practice for calculating uncertainty in DFCI equipment. The output of the uncertainty analysis in the case of DFCI is a linear value (usually in microns) for the specific gage, master gear and part to be measured. The recommended practice is to set an operating tolerance that is inside the required tolerance by at least the amount of the uncertainty result obtained by the following analysis. For example, if a TCE specification is 100 microns and the uncertainty analysis shows a potential of 10 microns of measurement uncertainty, then the design specification should be reduced from 100 to 90 microns in order to meet the original requirement.

**The U95 measurement for uncertainty.** Equation 25 is the basic form of the U95 measurement for uncertainty as described in Reference 5:

NOTE: All parameters must be in units of like measure ( $\mu\text{m}$  or  $\mu\text{in}$ ) (25)

$$U_{95} = K \sqrt{U_M^2 + U_{R1}^2 + U_A^2 + U_P^2}$$

where:

$U_{95}$  total uncertainty model with the measuring system and process taken the statistical 95 percent confidence level

$K$  statistical coverage factor for a specific confidence level

$U_M$  uncertainty associated with the specific accuracy of the master gear

$U_{R1}$  uncertainty associated with the repeatability of multiple rolls, usually determined by artifact or alternate process

$U_{R2}$  uncertainty associated with the system reproducibility element of the measuring system process

$U_A$  uncertainty associated with the gage blocks or setting discs used to set up tight mesh center distance or test radius according to its calibration accuracy; this uncertainty is not needed for calculations related to total composite error or tooth-to-tooth error, since this additional calibration is not required for that measurement

$U_P$  uncertainty associated with the probe or instrumentation readout

Further explanation of these factors with a calculation of the same test case as the gage R&R example is detailed in the sections that follow.

**Coverage factor, K.** The coverage factor is used to expand the uncertainty estimation on the basis of the level of the confidence interval. For a 95 percent confidence interval, a value of  $K=2.0$  is appropriate.

NOTE:  $K$  is derived from the student 't' distribution, as sample size goes to infinity. Within 95 percent confidence intervals 't' converges to 1.960, as described (Ref. 10). For the calculation of uncertainty, the coverage factor is typically rounded up to 2.0.

**Accuracy class of the master —  $U_M$ .** The accuracy results on the double-flank tester must also account for error in the master gear. Master gears usually come with a certification for either total composite error or run-out error. If the total composite variation of the master is available, its value is to be used in the equation:

$$U_M = \frac{F_{idv3}}{\sqrt{3}} \quad (26)$$

where:

$F_{idv3}$  is the actual total composite variation of the master

If only a run-out certification is available for the master, the equation is modified to adjust for the use of the run-out as follows: (27)

$$U_M = \frac{1.35 F_{r3}}{\sqrt{3}}$$

where:

$F_{r3}$  is the actual run-out of the master

In this case study,  $F_{r3}$  was determined by certification to be  $4.4 \mu\text{m}$ . Therefore,

$$U_M = \frac{1.35 F_{r3}}{\sqrt{3}} = \frac{1.35 (4.4)}{\sqrt{3}} = 3.4295 \mu\text{m}$$

**Repeatability uncertainty —  $U_{R1}$ .** Repeatability is the variation between successive measurements of the same item, taken the same way, under the same conditions. Repeatability is based on a minimum sample of 30 measurements with a dedicated artifact such as:

- Two master gears rolled together
- A master and a test gear rolled together
- An eccentric disk running against a fixed mandrel
- A concentric disk with OD flats running against a fixed mandrel
- Measuring test radius against gage blocks or a calibrated master gage

Further information on artifacts can be found in Reference 6.

In the case of rolling two master gears, the gears shall be tooth indexed, with the teeth re-set to the same positions with every roll.

Multiple rolls of a master gear with a plastic or powder metal test gear usually result in less repeatability than other methods. If this method is chosen, use lubrication between the master and test gear.

The repeatability uncertainty can be estimated as follows: (28)

$$U_{R1} = \frac{\sigma_{30}}{2}$$

where:

$\sigma_{30}$  is the standard deviation over 30 rolls of the double-flank parameter being evaluated

In this case study,  $\sigma_{30}$  was determined by measurement of center distance on a double-flank gage using gage blocks between mandrels to be 2.0828  $\mu\text{m}$ . Therefore,

$$U_{R1} = \frac{\sigma_{30}}{2} = \frac{2.0828}{2} = 1.0414 \mu\text{m}$$

**Reproducibility uncertainty —  $U_{R2}$ .** Rolling a hardened steel master gear against an unfilled, thermoplastic involute under a tight mesh pressure will induce surface point deflections and flank wear—even at the most minute and microscopic levels. For this reason—and particularly for plastic gearing—it is recommended to use the lowest possible pre-set test force that generates repeatable results.

Uncertainty associated with the reproducibility of the measurement system is a function of repeated inspection equipment set-ups and any bias induced through different operators. The component of reproducibility should be determined with a minimum of three operators and five different parts. Each part with each operator is set-up anew with the inspection equipment and measured only once; one master gear and five test gears are required. The master and each test gear should be indexed to start and end at the same tooth position with every appraiser's roll. The total variation is taken as the mean standard deviation between all parts and appraisers.

The reproducibility uncertainty can be estimated as half of the mean standard deviation between the appraisers as follows: (29)

$$U_{R2} = \frac{\sigma_A + \sigma_B + \sigma_C}{6}$$

where:

$\sigma_A, \sigma_B, \sigma_C$  are the standard deviations for appraisers A, B and C, and the five test parts on the double-flank parameter being evaluated

Using the measurement data from the gage R&R case study—

$$\begin{aligned} \sigma_A &= 3.115 \mu\text{m} \\ \sigma_B &= 3.117 \mu\text{m} \\ \sigma_C &= 3.119 \mu\text{m} \end{aligned}$$

$$U_{R2} = \frac{\sigma_A + \sigma_B + \sigma_C}{6} = \frac{3.115 + 3.117 + 3.119}{6} = 1.0414 \mu\text{m}$$

**Uncertainty of the master gage blocks or setting discs —  $U_A$ .**

When measuring tight mesh center distance or test radius, an additional calibration step must be made between the mandrels that hold the test gear and the master gear. The standard uncertainty of the gage block or setting disc comes from its calibration report, hence:

$$U_A = U_{\text{Gage Block Calibration Error}} \tag{30}$$

where:

$U_{\text{Gage Block Calibration Error}}$  is the difference between the calibrated value and the nominal value of the gage block or setting disc used

*NOTE: For setting discs it may be appropriate to use half the calibrated value if the calibration is based on a diameter and only the radial portion is used.*

For total composite and tooth-to-tooth error in this case study—

$$U_A = 0 \mu\text{m}$$

since the gage block was not used for those readings.

For tight mesh center distance or test radius—

$$U_A = 0.0508 \mu\text{m}$$

which was the calibration error associated with the gage block employed.

**Uncertainty of the measuring probe or instrumentation readout —  $U_p$ .** In the case of electronic gages, the transducer usually has a calibration certificate associated with the calibration error of the reading. In the case of a dial indicator, a calibration result would need to be obtained through the gage calibration procedure. The uncertainty factor related to the probe or instrument readout is:

$$U_p = \frac{U_{\text{Probe Calibration Error}}}{\sqrt{3}} \tag{31}$$

For this case study an electronic probe was used with a calibration reading error of 1.05  $\mu\text{m}$ .

Therefore,

$$U_p = \frac{1.05}{\sqrt{3}} = 0.6062 \mu\text{m}$$

**Uncertainty case study/numerical example.** For the same case study as the previous gage R&R example using Equation 25, the potential variation of the double-flank measurement system (i.e., uncertainty) is:

$$\begin{aligned} U_{95} &= K \sqrt{U_M^2 + U_{R1}^2 + U_A^2 + U_p^2} \\ &= 2.0 \sqrt{3.4295^2 + 1.0414^2 + 1.5685^2 + 0^2 + 0.6062^2} = 7.918 \mu\text{m} \end{aligned}$$

For the same case study data as the gage R&R case study example—but with added uncertainty for tight mesh center distance or test radius—the potential uncertainty is:

$$\begin{aligned} U_{95} &= K \sqrt{U_M^2 + U_{R1}^2 + U_A^2 + U_p^2} \\ &= 2.0 \sqrt{3.4295^2 + 1.0414^2 + 1.5685^2 + 0.0508^2 + 0.6062^2} = 7.919 \mu\text{m} \end{aligned}$$

The total composite tolerance on the part from the previous gage R&R study is 76.2  $\mu\text{m}$ . The potential uncertainty of our measurement system is approximately 7.92  $\mu\text{m}$ . This means that, for practical purposes, the total composite measurement should be limited to 76.2 – 7.92 = 68.3  $\mu\text{m}$  using the uncertainty approach. This is done in order to be confident that true values of measurement will not exceed 76.2  $\mu\text{m}$ . In this case the uncertainty of our measurement system represents 10.4 percent of the total composite error specification.

In contrast, based on the exact same gaging methodology, the gage R&R result would be an unacceptable 80.3 percent.

Uncertainty analysis presents a practical and acceptable alternative for measurement system analysis in dynamic double-flank composite inspection vs. the traditional gage R&R.

## Recommendations for Use

At its best, DFCI is used as a screening tool developed for in-process, real-time manufacturing inspection of production gears. Used this way, double-flank composite inspection has, for many years, proven invaluable to conveniently determine changes in gear process and quality elements. Individual gear elemental quality usually cannot be discerned from the results. However, the results can flag a response that indicates there is a change or issue that can be further investigated and resolved. Many gear suppliers and customers successfully rely on a maximum value of total composite error and maximum tooth-to-tooth error to approve or reject a part or lot as an economical form of inspection and validation.

If the value of TCE and TTE is specified intelligently, results in statistical control can be very insightful, relative to gear quality and even performance. When designing gears, proper allowances need to be made for total composite tolerances to ensure that operational backlash will not be compromised. Tight mesh center distance is a powerful way to control functional tooth thickness for backlash control. Although test radius is a specification that has been widely used in the past, tight mesh center distance should always be specified instead of test radius to avoid ambiguity.

Master gear designs should be verified for proper mesh on the gage with the test gear at the maximum and minimum tolerance according to the recommendations in this document.

Statistical methods are a powerful way to assist in the development of tooling for production and for monitoring ongoing production capability in a cost-effective manner. These methods include:

Initial, total composite error probability plots to determine if sample variation is expected or includes special causes when used for evaluating gear tools and dialing in manufacturing processes (Figs. 9a and 9b).

Initial and ongoing total composite error Cpk snapshots to report the strength and robustness of the process, relative to the specified design limits (Fig. 10).

Ongoing probability distribution plots to report predictive values of total composite error, relative to an arbitrary center line. Reporting the percentage of predicted TCE values greater than the middle of the actual design specification gives a good sense and position of where the quality level may be in the future (Fig. 11).

Control charting of tooth-to-tooth error in near-real-time, since it will be the first and most critical flag to reveal if the gear manufacturing process is stable or trending towards increasing or decreasing variation. TTE should be used for predicting and investigating assignable causes of unexpected variation (Fig. 12).

Ongoing capability analysis of tight mesh center distance. Properly interpreted, tight mesh center distance can be a more useful tool in controlling gear quality statistically than total composite error, since it includes the effect of tooth thickness. Adjustments in the ongoing process should be considered when practices as outlined are followed (Figs. 13 and 14).

These methods are insightful at discerning actual and potential gear quality issues that cannot be seen in any other way. This is particularly significant when dealing with high-value-added assemblies.

Although gage R&R is the industry norm for measurement system validation, uncertainty analysis is a better way of dealing with a dynamic measurement system such as double-flank gear inspection.

Although not discussed in this document, further consideration may be made to map double-flank composite inspection charts with in-process flags that help control positive and negative performance issues such as noise, vibration, backlash and design life implications.

This subject may make for a meaningful future discussion opportunity. 

## References

1. AGMA 930-A05. Calculated Bending Load Capacity of Powder Metallurgy (PM) External Spur Gears; Annex E: Calculations of Inverse Functions for Gear Geometry.
2. Eberle, F.P. "The Real Truth Behind Cpk and Ppk Capability and Potential Process Studies," *Gear Solutions*, October 2012, pp. 40-46.
3. GR&R Definition. <http://www.dmaictools.com/dmaic-measure/grr>.
4. Bower and Touchton. "Evaluating The Usefulness of Data by Gage Repeatability and Reproducibility," [http://www.minitab.com/uploadedFiles/Shared\\_Resources/Documents/Articles/evaluate\\_usefulness\\_of\\_data\\_gage\\_r\\_r.pdf](http://www.minitab.com/uploadedFiles/Shared_Resources/Documents/Articles/evaluate_usefulness_of_data_gage_r_r.pdf).
5. AGMA ISO 10064-5-A06. Code of Inspection Practice-Part 5: Recommendations Relative to Evaluation of Gear Measuring Instruments.
6. ANSI/AGMA 2116-A05. Evaluation of Double-flank Testers for Radial Composite Measurement of Gears.
7. ANSI/AGMA 2015-2-A06. Accuracy Classification System: Radial Measurements for Cylindrical Gears.

For Related Articles Search

double flank

at [www.geartechnology.com](http://www.geartechnology.com)

**Fred Eberle** is a technical specialist in the development of gearing, drive motors and power closure devices in the automotive industry. Over the last 24 years he has worked as a gear development engineer in the mill gearing, lawn & garden and commercial industrial gear industries. He has a bachelor's degree in mechanical engineering from the Rochester Institute of Technology and is a certified Six Sigma Master black belt. Eberle's participation in various AGMA technical committees spans 23 years, having served as chairman of the Powder Metallurgy Committee, and currently on the Plastic and PM Gearing Committees. Eberle has authored several papers on gearing, measurement system analysis and process statistics.



**Ernie Reiter, P. Eng.** a consultant specializing in the design of gears and geared products, received his degree in mechanical engineering in 1985 from the University of Waterloo in Ontario, Canada. He has authored modern software on gearing and other mechanical components, providing his clients with gearing-related design, consulting, software, gaging, training, and support. Reiter has worked in the field of plastics part production for the automotive industry, specializing in tooling development and directing the manufacture of molded plastic gears. As part of his engineering duties he has acquired advanced skills in computer graphics and their application to gear geometry. Reiter is active in five AGMA technical committees, including vice chair positions in both the Plastics and the Powder Metal Gearing Committees, and is an active participant on the committees for Gear Accuracy, Worm and Fine-Pitch Gearing. Company website: [www.webgearservices.com](http://www.webgearservices.com); email: [ereiter@webgearservices.com](mailto:ereiter@webgearservices.com).



# Sandvik Coromant

## TEAMS WITH STAR SU FOR GEAR MILLING

Sandvik Coromant has teamed up with Star SU on an extended basis. Beginning as an authorized OEM agent, and now a national channel partner with Sandvik Coromant for gear milling tools, Star SU is a provider of gear related tools and milling cutters in the Americas. "Our relationship began with collaboration on a key OEM project and rapidly advanced from there. With broad expertise in the gear milling market, both Sandvik Coromant and Star SU share mutual interests in market positioning," says Sandvik's Gear Milling Business Development Manager for Market Area Americas, Brent Marsh.



"Recognizing that the gear industry is rapidly changing, together we saw an opportunity to bring advanced solutions to customers. Early on we could see that Sandvik Coromant's industry-leading carbide grade technology combined with Star SU's significant foothold in the gear making industry, we would make a more than robust team. Not wasting any time, we quickly reached an agreement for Star SU to be a global OEM which improved our reach in the U.S. In the U.S. we extended that partnership to make Star SU an official distributor."

Sandvik Coromant brings innovative and highly flexible indexable insert technology that fits into the broader industry trend. As the industry authority on carbide grade metal cutting technologies, Sandvik Coromant's indexable carbide solutions for gear cutting operations effectively complements Star-Su's current line of gear cutting tools. "Customers of Sandvik Coromant and Star SU can expect higher productivity, lower overall cost and innovative solutions to gear challenges," Marsh adds.

"We clearly see that a massive shift is underway and we expect it to change the industry drastically within ten years. The trend now is towards a more flexible approach with a strong demand for higher productivity. We also see that there will be a need for more responsive service and support around the world. This demand will increase further due to high precision manufacturing of gears in emerging markets," Marsh says.

In recognition of indexable carbide technologies and methods like InvoMilling and Power-skiving, Sandvik Coromant has

invested a great deal in this technology and will continue to do so in the long term.

"While the gear tooling market has faced recent challenges with things like a pull-back in the mining industry and wind energy production, we see this as a minor stumbling block. In fact, we see strong growth in the next several years to come as gear manufacturing is expected to expand more than metal cutting on average due to investments in transportation, infrastructure, energy and mining. More challenging materials will be introduced due to higher efficiency and environmental demands. The gear segment has a bright future!" Marsh adds.

Sandvik will continue to broaden its product lines in gashing, hobbing, and flexible CNC areas of gear milling. The company has some new offerings in smaller gashing tools that are especially good for spline cutting. "Our latest product, CoroMill 171, will expand options to implement the InvoMilling method and will be available in the fall of 2014. The market is very eager to get access to this groundbreaking technology. Power skiving is another area of focus for Sandvik Coromant and this method will also become available in the second half of 2014. Power skiving offers customers a reduction of machining time by 60-80 percent versus traditional methods," Marsh says.

Both Sandvik and Star SU promise some interesting things for the future of gear milling during IMTS later this year. "We cannot really spill the beans, but one thing we can promise: we will surprise a lot of people at IMTS. Our channel partner, Star SU, will also be exhibiting at IMTS and will display Sandvik Coromant gear solutions and tools," Marsh says.

## Siemens

### AWARDS SOFTWARE GRANT TO OHIO COLLEGE

From its historic Norwood Motor Manufacturing Facility, Siemens recently announced a \$66.8 million in-kind software grant to Cincinnati State Technical and Community College. Students there will now have access to the same Siemens product lifecycle management (PLM) software used throughout the global manufacturing industry to design, develop and manufacture some of the world's most sophisticated products in a variety of industries, including automotive, aerospace, biotechnology, machinery, shipbuilding, and high-tech electronics.

"The manufacturing industry in America is on the rise and it is being transformed by a software revolution that is enhancing





productivity, increasing efficiency and speeding time to market," said Chuck Grindstaff, president and CEO, Siemens PLM Software. "This revolution requires a highly trained workforce. With this grant, Cincinnati State Technical and Community College will be able to integrate world-class PLM technology into its curriculum, so that its students are even better prepared for co-op assignments and for high-quality manufacturing jobs."

Cincinnati State President O'dell M. Owens expressed gratitude for the grant, and said it will be put to good use. "Cincinnati State is a career college, and we're known for our strong business relationships. This software grant from Siemens allows us to send our graduates into the manufacturing workplace ready to go the minute they walk in the door. That will be a huge competitive advantage for them and an even greater asset for the Cincinnati business community."

Siemens' software will be used in Cincinnati State's Center for Innovative Technologies to support its mechanical engineering and industrial design technologies programs, as well as other programs at the college. Computer labs on the Clifton campus will be supplied with Siemens software to support computer-aided design (CAD) courses. Students and faculty will use the software in assignments and research related to mechanical engineering, industrial design and manufacturing management.

## Wenzel America

HIRES REGIONAL SALES MANAGER

Wenzel America recently announced the hiring of **Drew Shemenski** for the position of regional sales manager of the Midwest. Shemenski brings more than 15 years of manufacturing and metrology experience to the Wenzel team. For the last 12 years, Shemenski has worked at Carl Zeiss Industrial Metrology in a variety of technical, sales and operational positions. Most recently, he successfully opened and managed the Zeiss Technical Center in Irvine, California. "Drew brings a diverse background and great industry knowledge to our sales team," said Andy Woodward, president of Wenzel America. "His experience and customer focus fit perfectly with the Wenzel vision, and will no doubt be part of our continued growth and success." Shemenski will work out of the Wenzel America headquarters in Wixom, Michigan. He will be responsible for sales activities in the Great Lakes region, as well as the upper Midwest.





**NEW RELEASE**



### Highlights 03/2013

- Improved contact analysis of cylindrical gear pairs and planetary systems
- Sizing of plastic gears according to VDI 2736
- Automatic, easily customized, generation of manufacturing drawings
- Fine sizing of worm wheels and crossed helical gears
- New DIN 743 and FKM in the shaft calculation
- KISSsys assistant for planetary models

KISSsoft USA, LLC  
3719 N. Spring Grove Road  
Johnsburg, Illinois 60051  
Phone (815) 363 8823  
dan.kondritz@KISSsoft.com

Get your free trial version at  
[www.KISSsoft.com](http://www.KISSsoft.com)

# Recontrolling, Rebuilding, Service & Repair

*We are your trusted source!*

■ SHAPING



■ HOBBING



■ GRINDING





When it comes to your shaping, hobbing and grinding applications, choose MTB for reliability, quality, innovation, accuracy and value.



[www.machinetoolbuilders.com](http://www.machinetoolbuilders.com)

815.636.7502

**GEAR CUTTING TOOLS**   
**MADE IN SWITZERLAND**

**SCHNYDER**  
 GEAR CUTTING SOLUTIONS  
 60 YEARS OF TOP TECHNOLOGY

US Distributor  
**HANIK CORPORATION**  
 PHONE 630-595-7333  
 FAX 630-595-7343  
 www.hanikcorp.com  
 email: hanikcorp@aol.com

ph: 011-41-32-344-0400 • fax: 011-41-32-344-0404 • www.schnyder.com • mail@schnyder.com

# Venmark International

OFFERS WHITE PAPER ON PRODUCT PUBLICITY

A new white paper for engineers and other non-marketing small business owners that explains what publicity can accomplish in the contemporary marketing mix and features 10 rules for preparing effective news releases is being offered by Venmark International of Wellesley, Massachusetts. "The Engineer's Guide to Product Publicity," is a five-page paper which explains what publicity is, why it is

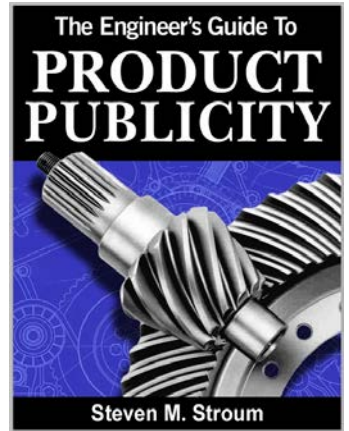

the most cost effective marketing tool, and how to use it get a company branded as a problem-solver. Featured are 10 rules for preparing effective news releases including adopting a giving mindset, eliminating advertising jargon, and quantifying all performance claims. Written by Steven M. Stroum, founder and president of Venmark International, "The Engineer's Guide to Product Publicity" will help readers understand the value of press releases to media outlets, what they can achieve as a marketing tool today, and their value for creating meaningful web content. "The Engineer's Guide to Product Publicity" is available free from Venmark International. To order the white paper, visit [www.venmarkinternational.com](http://www.venmarkinternational.com).

**100**  
**SUHNER**  
 1914 - 2014

**Transmission expert.**  

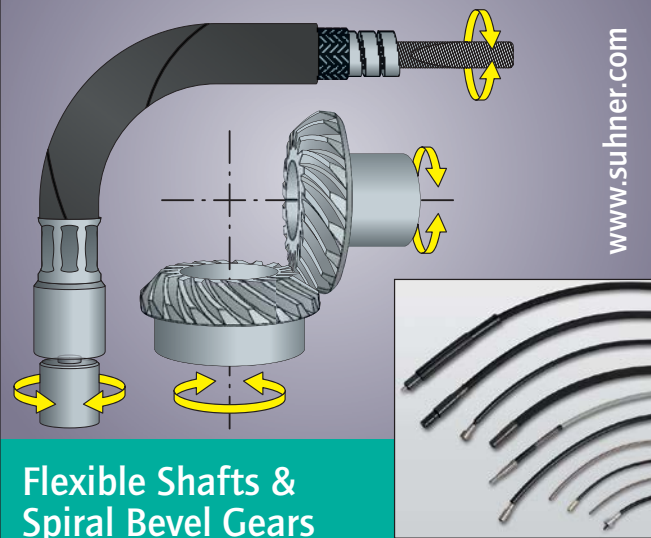



**Flexible Shafts & Spiral Bevel Gears**

Two different ways to transmit rotary motion.

**SUHNER**

SUHNER Manufacturing Inc. · Rome, GA 30161  
 Phone: 706-235-8046 · [info.usa@suhner.com](mailto:info.usa@suhner.com)



[www.suhner.com](http://www.suhner.com)

# Solar and ASM

OFFER VACUUM HEATTREATING COURSE

Solar Atmospheres and ASM International at Materials Park in Ohio have partnered to offer a new vacuum heat treating course. This new course provides students with a means to combine basic vacuum heat treatment theory with hands-on instruction using the new ASM laboratory vacuum furnace



donated by Solar Atmospheres, Inc., and manufactured by Solar Manufacturing Inc.

The first class of the new ASM course offering was convened in December 2013, with subsequent courses scheduled for April 2014, and September 2014. The course was developed by Solar Atmospheres' consultant in chemistry and metallurgy, Virginia Osterman, Ph.D., who works closely with the Solar Atmospheres Research and Development group. This course covers the background of vacuum measurement, vacuum furnace design, and vacuum technology as it applies to various metallurgical processes. Dr. Osterman noted, "Having a basic understanding of vacuum theory and its application in heat treating in itself is valuable; however, with the added benefit of the new 'Mentor' vacuum furnace students now can see how to put theory into practice and get a better understanding as to why the use of vacuum heat treat processes add value to a product."

## Celanese Corporation

### WINS SUPPLIER AWARD

Celanese Corporation, a global technology and specialty materials company, received Whirlpool's Best Supplier Award 2012/13 for outstanding performance on quality, delivery and customer service. Presented during the Whirlpool Latin America Supplier's Day event on Nov. 27 in São Paulo, Brazil, Celanese won the Best Supplier Award for the first time and has been one of the household appliance manufacturer's preferred suppliers of engineered materials for more than 15 years.



Pictured on stage (left to right) during the awards ceremony were Lígia Faber Corrêa da Silva, Camile Oliveira, Guert Rucker, Daniella D. Taurizano and Paulo Miri.

"This Best Supplier Award from Whirlpool is the result of our ability to not only deliver world-class engineered materials, but to meet our customer's 'critical to quality' wants and needs with our existing products or to develop new materials with new performance characteristics," said Guert Rucker, South America commercial director – Celanese. "By working closely with Whirlpool we deliver value through collaboration, tech-

**RMC**  
**FROM PROTOTYPE TO PRODUCTION**  
**GNC**  
**Your Source for High Precision Large Component Machining and Gear Cutting.**  
**Serving the Industry for over 65 Years**  
**RMC**  
 Richardson Manufacturing Company  
 www.rmc-BIGCNC.com Tel: 217-546-2249

## Spiral Bevel Gears

- Spiral & straight bevel gear manufacturing.
- Commercial to aircraft quality gearing.
- Spur, helical, splined shafts, internal & external, shaved & ground gears.
- Spiral bevel grinding.
- Midwest Transmissions & Reducers.
- ISO compliant.



Midwest Gear & Tool, Inc.  
 15700 Common Rd., Roseville, MI 48066  
 Tel: 586.779.1300 midwestgear@sbcglobal.net



BEYTA GEAR SERVICE 

PUTTING  
A LIFETIME

OF

GEAR  
DESIGN

EXPERIENCE

TO WORK FOR YOU

- Reverse engineering
- Gearbox upgrades
- Custom gearbox design
- Specification development
- Project management
- Vendor qualification
- Design reviews
- Bid evaluations
- Tooling design
- Customized gear training
- Equipment evaluation
- Custom machine design

**Charles D. Schultz**  
**chuck@beytagear.com**  
**[630] 209-1652**

[www.beytagear.com](http://www.beytagear.com)

nology and real solutions that help them quickly develop new, innovative products.”

Phil McDivitt, vice president and general manager of the engineered materials business of Celanese added, “Celanese is using the full breadth of its chemistry, technology and product expertise to create value at Whirlpool on a global basis. As a collaborative high-performance engineered materials supplier, our global commercial and technical teams are working closely with Whirlpool development teams at their facilities in Benton Harbor, Michigan., Shanghai, China, Cassinetta, Italy, Manaus, Rio Claro, Brazil and Joinville, Brazil.”

## PTG

### ENGINEER SECURES 2014 AMTRI SCHOLARSHIP

The Manufacturing Technologies Association (MTA) awards dinner was held at Birmingham’s International Convention Centre on February 6, 2014. It provided Adam Hazeldine – one of PTG Holroyd Precision’s young engineers – with an incredible reason to celebrate. That’s because during the event, Hazeldine, 26, was richly rewarded for his diligence and hard work to date with the presentation of the coveted AMTRI Scholarship. Supported by Lloyds TSB Commercial, the scholarship will assist Hazeldine in completing an MBA in order to pursue his goal of a management position with his Rochdale-based employer.

Two other Precision Technologies Group employees, Bradley Mooney, 27, and Jordan Beard, 25, were short-listed for the prestigious MTA Young Engineer of the Year award – further proof of the high quality of PTG’s personnel and the importance the organization places on providing first-class staff training.

A valued and well-respected member of the PTG Holroyd team, Hazeldine is now employed as a design engineer with the company. He offers a solid understanding of its technologies and has been heavily involved in development work surrounding the Holroyd Zenith 400 helical profile grinder. He has also recently been made a member of the company’s lean manufacturing team and an internal auditor. He also works as a junior project engineer, involved in PTG Holroyd’s latest machine tool developments.



**Caption: Richard Holden of Lloyds Bank (left), presents the 2014 AMTRI Scholarship to Adam Hazeldine (center), with impressionist and comic, Alistair McGowan (right).**



ACCU-DRIVE, INC.  
610 West Pershing Rd.  
Chicago, IL. 60609



## PRECISION GEAR GRINDING

- Spur / Helical up to 59" O.D. – 26" Face
- Accurate quotes – Competitive prices – Fast turn-around
- Emergency “breakdown” support
- Support system for OEM parts
- Full complement of testing equipment for complete and comprehensive charting. Calibrated and certified on a regular schedule.

Trusted by OEM, MRO and Gear Job Shop customers for nearly two decades.

Your project is as important to us as it is to you.

**(773) 376-4906**

[www.Accudrv.com](http://www.Accudrv.com)  
[gears@accudrv.com](mailto:gears@accudrv.com)



8th International

Plus: Transmission Expo

# CTI Symposium

## Automotive Transmissions, HEV and EV Drives



USA

12-15 May 2014, Royal Park Hotel Rochester, MI

The World's Largest TM & Drives Events With Over 1,800 Senior Delegates in the USA, China & Europe in 2013!



**Don Hillebrand**  
Director of Center for Transportation Research,  
Argonne National Laboratory  
U.S. Department of Energy, USA



**Daniel M. Hancock**  
President,  
SAE International, USA



**Michael Olechiv**  
Director - Light-duty Vehicle and  
Small Engine Center, U.S. EPA, USA



**Chris Nevers**  
Director Climate and Fuel Economy,  
Automotive Manufacturers Alliance, USA



Mercedes-Benz



### Industry Experts Will Discuss e.g.

- 54.5 MPG Challenge - What can transmission and drive technology contribute to meet the future target?
- Technology and advantage of the new ATs, CVTs and DCTs
- How to meet ISO26262 requirements in transmission development
- Ways to solve NVH issues
- What can latest technologies contribute to optimize TM manufacturing and production

### PLUS 2-Day Introductory Seminar

Basics and practice of automotive transmissions specially tailored to those who want to refresh their knowledge or start working in this business field

### PLUS Transmission Expo

27 companies showing new products and developments  
New companies joining the exhibition!

### PLUS Evening Networking Party

A fabulous opportunity to network with your international peers!

### PLUS Extended Program:

4 parallel sessions on 14th and 15th May!

### Receive Your Technology

### Updates From Companies Such As:

- Bosch Transmissions
- GETRAG
- Jatco
- Punch Powertrain
- AVL
- Magna
- Ricardo
- Schaeffler
- IAV
- Drive System Design
- Fallbrook Technologies
- FEV
- Gesellschaft für Industrieforschung mbH
- hofer forschungs- und entwicklungs GmbH
- IHS Automotive
- Technical University of Braunschweig
- Technical University of Munich

### Sponsors



SCHAEFFLER



[www.transmission-symposium.com/usa](http://www.transmission-symposium.com/usa)

**April 7–11 – Basic Training for Gear Manufacturing.**

Richard J. Daley College, Chicago. The AGMA Training School for Gear Manufacturing will enable you to become more knowledgeable and productive. The Basic Course teaches students to set up machines for maximum efficiency, to inspect gears accurately, and to understand basic gearing. Although the Basic Course is designed primarily for newer employees with at least six months' experience in setup or machine operation, it has proved beneficial to quality control managers, sales representatives, management, and executives. This course offers training in: gearing and nomenclature, principles of inspection, gear manufacturing methods, hobbing, shaping and more. Although all training is basic, on manual machines, everything that students learn is valid and applicable with the CNC equipment commonly in use. By using manual machines, students can see the interaction between the cutting tool and the workpiece. They understand the process and the physics of making a gear. For more information, visit [www.agma.org](http://www.agma.org).

**April 7–11 – Hannover Messe 2014.** Hannover Fairgrounds, Hannover, Germany. The world's leading trade show for industrial technology returns in 2014 with a full lineup of trade shows under the banner "Integrated Industry-Next Steps." The seven co-located shows include Industrial Automation; MobiliTec; Digital Factory; Industrial Supply; IndustrialGreen Tec; Research and Technology; and Energy. The Netherlands is the official partner country in 2014. Discover new perspectives on energy, automation and industrial supply and engineering topics, as well as a broad range of events and displays affecting today's global industrial market. Other Hannover highlights include the Robotics Award, the 11th WoMenPower Conference, Metropolitan Solutions, economic forums, job and career fair and more. For more information, visit [www.hannovermesse.de](http://www.hannovermesse.de).

**April 10–12 – 2014 AGMA-ABMA Annual Meeting.**

Vinoy Renaissance Resort and Golf Club, St. Petersburg, Florida. Expert presentation topics include "Accountability and Achievement;" "Global Megatrends: Major Forces in Manufacturing;" "Unconventional Oil and Gas: Game Changer If We Don't Screw it Up;" "Economic Outlook;" and "How to Turn Republicans and Democrats into Americans." The annual golf tournament returns, as well as the First Timers Reception on Thursday night prior to the Welcome Reception. Friday night features the "Sounds of Soul" and Saturday night features "Hot Havana Nights" with a cigar-making demonstration. The hotel features an 18-hole golf course, private marina, and 12 tennis courts, in addition to newly renovated meeting, gathering and sleeping rooms. It is ideally located near Tampa International Airport, St. Pete Beach and downtown St. Petersburg, home to the Salvador Dali and Chihuly museums. For more information, visit [www.agma.org](http://www.agma.org).

**May 6–8<sup>th</sup> – Vacuum Carburizing Symposium.** Ford Motor Company Conference and Exposition Center, Dearborn, Michigan. The ALD Holcroft Vacuum Carburizing Symposium will feature two days of information and presentations by industry experts, with audience participation. The evening of May 6 will be highlighted by a private cocktail and dinner reception at a Ford light truck assembly facility. Guests will have plenty of networking opportunities and the chance to enjoy multimedia experiences along with private tour access to an actual Ford Motor Company assembly line in operation. Presentation topics will be announced in early 2014 and will cover highly specific and technical subjects relevant to the vacuum carburizing process, including recent innovations, best practices and the business of vacuum carburizing. For more information, visit [www.aldholcroft.com](http://www.aldholcroft.com).

**May 6–8 – MFG 2014.** Connecticut Convention Center, Hartford. Manufacturing is growing and changing... moving from low value repetitive assembly to high value, technology-rich products and services. To serve the evolving needs of East Coast industry, SME produces this exclusive event for aerospace, defense (including arms), medical, and micromanufacturing. These three major industries plus one strategic technology are driving change through their supply chains and leading the way in innovation and collaboration. Mfg4 surpasses the traditional manufacturing technology event by delivering content and suppliers mandated by industry. Mfg4 is an event for industry, developed by industry, with an emphasis on industry-specific solutions with attention to cross-collaboration. Technology Zones include additive manufacturing; automation; contract manufacturing; finishing and coatings; joining and fabrication; materials; micromanufacturing; machining, tooling and inspection; software; and design. For more information, visit [www.mfg4event.com](http://www.mfg4event.com).

**May 21–22 – AGMA Spring Marketing & Forecasting Conference 2014.**

Crowne Plaza O'Hare, Rosemont, Illinois. Growing automotive production, housing construction and capital spending are positive indicators for gearing in the near term. But, our industry faces risks from uncertain government policies, a slowing energy sector and weak markets in Europe and Asia. The AGMA Marketing & Forecasting Conference will have a line-up of presenters to help make sense of these competing forces: AGMA's economists (IHS Global Insight) will give their assessment and forecast for the industry and 10 end user markets; two experts representing sales channels for manufacturers' representatives and agent and industrial distributors will discuss how to improve your sales through these two channels; special speaker on the evening of May 22 from the Chicago Federal Reserve. For more information, visit [www.agma.org](http://www.agma.org).



# COME TOGETHER.



**MIKE HAUPERS**  
President  
Swiss Precision Machining Inc.

**YEARS ATTENDING IMTS**  
25

**GOAL FOR IMTS 2014**  
To identify new equipment, tools, and technologies that will enhance our abilities - giving us the competitive edge needed to expand into new markets. After 40 years in the machining industry, I'm still amazed at how much more there is to learn. IMTS is where I go to get smarter.

# LEAVE SMARTER.

Where else can you meet the minds that are moving manufacturing forward? Nowhere but IMTS 2014. With a focus on success through cooperation, the week will be filled with technology, education, and ideas that we can all benefit from. Join us at McCormick Place Chicago, September 8-13, 2014. Learn more at [IMTS.com](http://IMTS.com).

**REGISTER NOW • [IMTS.COM](http://IMTS.COM)**



**COME TOGETHER.  
LEAVE YOUR MARK.**

- 3M Abrasives** – page 19  
[www.3M.com/cubitron2/GearGrinding](http://www.3M.com/cubitron2/GearGrinding)
- A.G. Davis/AA Gage** – page 31  
[www.agdavis.com](http://www.agdavis.com)
- Accu-Drive Inc.** – page 74  
[www.accudrv.com](http://www.accudrv.com)
- AFC-Holcroft** – page 28  
[www.afc-holcroft.com](http://www.afc-holcroft.com)
- ALD Thermal Treatment** – page 12  
[www.aldt.net](http://www.aldt.net)
- ALD-Holcroft Vacuum Technologies** – page 9  
[www.ald-holcroft.com](http://www.ald-holcroft.com)
- All Metals & Forge Group, LLC** – page 16  
[www.steelforge.com](http://www.steelforge.com)
- Applied Process** – page 4  
[www.appliedprocess.com](http://www.appliedprocess.com)
- Arrow Gear** – page 49  
[www.arrowgear.com](http://www.arrowgear.com)
- B&R Machine & Gear Corp.** – page 15  
[www.brgear.com](http://www.brgear.com)
- Beavermatic** – page 35  
[www.beavermatic.com](http://www.beavermatic.com)
- Beyta Gear Service** – page 74  
[www.beytagear.com](http://www.beytagear.com)
- The Broach Masters & Universal Gear** – page 29  
[www.broachmasters.com](http://www.broachmasters.com)
- Circle Gear** – page 79  
[www.circlegear.com](http://www.circlegear.com)
- CTI – Car Training Institute** – page 75  
[www.transmission-symposium.com/usa](http://www.transmission-symposium.com/usa)
- DTR Corp.** – page 21  
[www.dragon.co.kr](http://www.dragon.co.kr)
- ECM USA** – page 23  
[www.ecm-usa.com](http://www.ecm-usa.com)
- Excel Gear** – page 34  
[www.excelgear.com](http://www.excelgear.com)
- Forest City Gear** – page 7  
[www.forestcitygear.com](http://www.forestcitygear.com)
- Gear Consulting Group** – page 79  
[www.gearconsultinggroup.com](http://www.gearconsultinggroup.com)
- The Gear Machinery Exchange** – page 78, 79  
[www.gearmachineryexchange.com](http://www.gearmachineryexchange.com)
- German Machine Tools of America** – page 11  
[www.gmtamerica.com](http://www.gmtamerica.com)
- Gleason Corp.** – pages 40-41  
[www.gleason.com](http://www.gleason.com)
- Goldstein Gear Machinery LLC** – page 78, 79  
[www.goldsteingearmachinery.com](http://www.goldsteingearmachinery.com)
- Hans-Jürgen Geiger Maschinen-Vertrieb** – page 32  
[www.geiger-germany.com](http://www.geiger-germany.com)
- IMTS** – page 77  
[www.imts.com](http://www.imts.com)
- Index Technologies** – page 79  
[www.gallenco.com](http://www.gallenco.com)
- Ipsen International** – page 25  
[www.ipsenusa.com](http://www.ipsenusa.com)
- Kapp Technologies** – page 3  
[www.kapp-usa.com](http://www.kapp-usa.com)
- KissSoft** – page 71  
[www.kisssoft.com](http://www.kisssoft.com)
- Klingelberg – Outside Back Cover**  
[www.klingelberg.com](http://www.klingelberg.com)
- Koro Sharpening Service** – page 79  
[www.koroind.com](http://www.koroind.com)
- Leistritz Corp.** – page 17  
[www.leistritzcorp.com](http://www.leistritzcorp.com)
- Liebherr** – page 5  
[www.liebherr.com](http://www.liebherr.com)
- Luren Precision** – page 44  
[www.luren.com.tw](http://www.luren.com.tw)
- Machine Tool Builders Inc.** – page 71  
[www.machinetoolbuilders.com](http://www.machinetoolbuilders.com)
- McInnes Rolled Rings** – page 18  
[www.mcinnesrolledrings.com](http://www.mcinnesrolledrings.com)
- Midwest Gear & Tool Inc.** – page 73  
[midwestgear@sbcglobal.net](mailto:midwestgear@sbcglobal.net)
- Mitsubishi Heavy Industries** – page 37  
[www.mitsubishigearcenter.com](http://www.mitsubishigearcenter.com)
- Norton/St. Gobain** – page 45  
[www.nortonindustrial.com/vitrium3](http://www.nortonindustrial.com/vitrium3)
- Overton Chicago Gear** – page 43  
[www.oc-gear.com](http://www.oc-gear.com)
- Presrite Corp.** – page 33  
[www.presrite.com](http://www.presrite.com)
- Process Equipment** – page 39  
[www.gearinspection.com](http://www.gearinspection.com)
- Proto Manufacturing** – page 36  
[www.protoxrd.com](http://www.protoxrd.com)
- Reishauer – Inside Back Cover**  
[www.reishauer.com](http://www.reishauer.com)
- Richardson Manufacturing** – page 73  
[www.rmc-BIGCNC.com](http://www.rmc-BIGCNC.com)
- Schnyder S.A.** – page 72  
[www.hanikcorp.com](http://www.hanikcorp.com)
- Seco Tools** – page 20  
[www.secotools.com/us](http://www.secotools.com/us)
- Solar Atmospheres** – page 30  
[www.solaratm.com](http://www.solaratm.com)
- Star SU LLC** – pages IFC-1, 79  
[www.star-su.com](http://www.star-su.com)
- Stresstech Oy** – page 13  
[www.stresstechgroup.com](http://www.stresstechgroup.com)
- Suhner Manufacturing** – page 72  
[www.suhner.com](http://www.suhner.com)
- Zhengzhou Research Institute of Mechanical Engineering** – page 27  
[www.zrime.com.cn](http://www.zrime.com.cn)

## FOR SALE

### GLEASON TESTERS AIRCRAFT QUALITY

MODEL 27M HYPOID  
36.5" (900 mm) <.0001

MODEL 502 HYPOID  
10.5" (266 mm) <.0001

MODEL 13 UNIVERSAL  
13" (330 mm) <.0002

MODEL 6 UNIVERSAL ANGULAR  
7.5" (190 mm) <.0001

MODEL 6 (446) SPLIT-HEAD  
UNIVERSAL  
7.5" (190 mm) <.0001

MODEL 6 (446) SPLIT-HEAD  
UNIVERSAL  
7.5" (190 mm) <.00005



[www.gearmachineryexchange.com](http://www.gearmachineryexchange.com)

## FOR SALE

### LEES BRADNER 16" x 144"

ULTRA HEAVY DUTY  
STRAIGHT & HELICAL  
SPLINE HOBBER - 1975  
MARK III "B"

One of the last ones built  
Differential, Single Index Milling,  
Hard Ways  
Index plate, Gears, 25 HP



[www.gearmachineryexchange.com](http://www.gearmachineryexchange.com)





## School for Gear Manufacturing Technology

Conducted by  
**Geoff Ashcroft, Gear Consulting Group**

### 3 DAY CLASS

to cover the practical aspects of gear technology and geometry aiming toward a logical approach to trouble shooting and optimizing the manufacturing processes.

- Gear geometry and its relationship to gear generation.
- Gear inspection procedures and analysis.
- Understanding the processes of Hobbing, Shaping and Shaving.
- Trouble shooting the process from inspection data.
- Cutter wear and failure analysis.
- Cutter materials and coatings.
- Optimization of feeds and speeds.
- Hob shifting procedures and optimization.
- Use of standards.
- Open forum on attendee's experienced problems.



#### 2014 CLASS SCHEDULE

<b>May 20, 21, 22 / Detroit, MI</b> Hosted by Liebherr	<b>Sept 8,9,10 / Chicago Area</b> Hosted by Overton Chicago Gear	<b>\$975.00</b> including all documentation and lunch for all three days
<b>June 10,11,12 / Statesville, NC</b> Hosted by RP Machine	<b>October 15,16,17 / Anaheim, CA</b> Hosted by GMI (Gear Manufacturing Inc.)	

More information [www.gearconsultinggroup.com](http://www.gearconsultinggroup.com) Contact Bobbie ph: 904-392-0907 [gearconsulting@aol.com](mailto:gearconsulting@aol.com)

## KORO for Quality

### Hob Sharpening Service

- ◆ Quick Turnaround 2 Day Service
- ◆ Spur Shaper Cutter Sharpening
- ◆ HSS & Carbide Hob with center hole and straight flutes
- ◆ Thin Film Coatings
- ◆ Length up to 7 inches
- ◆ Diameter up to 5 Inches
- ◆ Precise rake and spacing guaranteed to AGMA standards
- ◆ **RUSH SERVICE AVAILABLE**



**Koro Sharpening Service**  
9530 85<sup>th</sup> Ave North  
Maple Grove, MN 55369  
763-425-5247  
[info@koroind.com](mailto:info@koroind.com)

## QUALITY CUSTOM GEARING!



Documented Quality Control Program

Inspection Lab including Complete Gear Tooth Diagnostics

**Tooth Cutting, Grinding & Shaving Services Available**

All Sizes & Configurations

- Reverse Engineering
- Design Analysis
- Complete Machine Shop Including CNC Machining



**Circle Gear and Machine**  
*Quality Custom Gearing Since 1951*

1501 South 55th Ct. • Cicero, IL 60804  
Ph: 708-652-1000 • Fax: 708-652-1100

*Please email your inquiries to [sales@circlegear.com](mailto:sales@circlegear.com) • [www.circlegear.com](http://www.circlegear.com)*

## SHARP HOBS

### Change Downtime To Productivity



You Need Your Tools Back **FAST**  
– Eliminating Downtime & Tuned To Meet or Surpass Original Design Specs and That's Where We Come In

- Stripping & Re-Coating
- Gear Shaper Sharpening
- Milling Cutter Sharpening
- Gear Tool Certifications



**Index Technologies**  
Gear Tool Reconditioning

Tel: 216-642-5900 • Fax: 216-642-8837 • 5755 Canal Road • Valley View, OH 44125  
Email: [gallen@gallenco.com](mailto:gallen@gallenco.com) [WWW.GALLENCO.COM](http://WWW.GALLENCO.COM)

### FOR SALE

## GLEASON TOOLING

Model 24A Standard & Extended Setting Gauges, TANRUFF 15" Universal Lower Die for Quench machines

- #39/#14 Long Test Bars
- #39/#39 Short Test Bars
- #39/#14 Short Test Bars
- #14/#14 Short Test Bars

Model 19/27 Wheel Setting Gauges  
Model 54/154 Planer Formers

[www.gearmachineryexchange.com](http://www.gearmachineryexchange.com)

### FOR SALE

## GEAR TOOLING

PIV RS-2-E Drive for Pfauter - UNUSED

GE-FANUC A06B-6059 Spindle Driver - UNUSED

ROHM OVS-230-552-326 Clamping Cylinder for Pfauter - UNUSED

ROHM OVS-150-552-490 Clamping Cylinder for Pfauter - UNUSED

ROHM OVS-85-453-00 C Clamping Cylinder for Pfauter - UNUSED

MAAG INT-1 Checker Internal Attachment

[www.gearmachineryexchange.com](http://www.gearmachineryexchange.com)

## Sharpening Service

for hobs, milling cutters, shaper cutters, shaving cutters and broaches

Service locations in:

- Hoffman Estates, IL  
Tel: 847.649.1450 Fax: 847.649.0112
- East Tawas, MI  
Tel: 989.362.0414 Fax: 989.362.2720
- Querétaro, México  
Tel: 52 442 217 34 45  
Fax: 52 442 217 34 46



[sales@star-su.com](mailto:sales@star-su.com)  
[www.star-su.com](http://www.star-su.com)

# BORN TO BLOG

## Blogging is BIG and getting bigger all the time.

There doesn't exist, for example, a news, industry, or entertainment entity that does not have at least one resident blogger.

And now, since January—we have ours.

"Ours" would be Chuck Schultz, as well-respected a gear man as there is in the business. He's witty. He knows his helicals and herringbones. And he can *write*. And he has *ideas about things*.

Like:

**On "The Beginning of Wisdom":** Make sure your pupils learn the common understanding of gear terms and can recognize non-standard usage when they see it. No matter what your "local dialect" is, they need to be able to converse with people outside your firm without having a translator present.

Or:

**On "100 Years of 4-Wheel Drive":** Particularly in areas like Chicago, creative people were introduced to the trade at one firm and over the course of their career they took that knowledge and developed new products, started new companies, and improved upon the things they saw others doing. It is still possible to do these things today. Just something to ponder as we wait for our SUVs to warm up for another commute through this challenging winter.

And:

**On "The Need for a Gear Industry Mt. Rushmore":** Recently there has been a lot of chatter about an NBA Mount Rushmore and which faces should be on it; certainly a worthy topic to debate at the local sports bar.

Chuck has worked in the gear industry for most of his life, beginning with coursework at Milwaukee's Area Technical College and, from 1972-1978, night classes at Marquette University, where he maintained a 3.5 of 4 GPA but fell 12 credits short of a BSME degree. Undeterred, Chuck went on to earn his professional engineer's license in the states of Wisconsin and Pennsylvania. He is the author of "An Introduction to Gear Design," "Gearbox Field Performance (AGMA FTM 1999)" and a number of articles and technical papers that have appeared in this publication. Besides his blog duties, Chuck also donates his valuable time as a *Gear Technology* Technical Editor.

Schultz's career path in the gear industry has been considerably less than straight and narrow, and that's the way he prefers it; Chuck's not a "30-years-later-and-where's-my-watch" kind of guy. He likes the gear gumbo—not the broth. Consider his stops along the way on his gear adventure, some of the benchmarks of the industry: Falk Corp., 8 years; Milwaukee Gear, 7 years; and Brad Foote, 12 years. Schultz now has his own consultancy, Beyta Gear Service ([gearmanx52@gmail.com](mailto:gearmanx52@gmail.com)).

But enough history. What you really need to know is that Chuck's blog "refreshes" every Monday, Wednesday, and Friday at [geartechology.com](http://geartechology.com). Look for "Blog" at the top of the page and click your gear-lovin' heart out. You'll find Schultz blogs on topics addressed on both the "hardware" and "software" side of things—the serious and the whimsical—but always informative and entertaining.

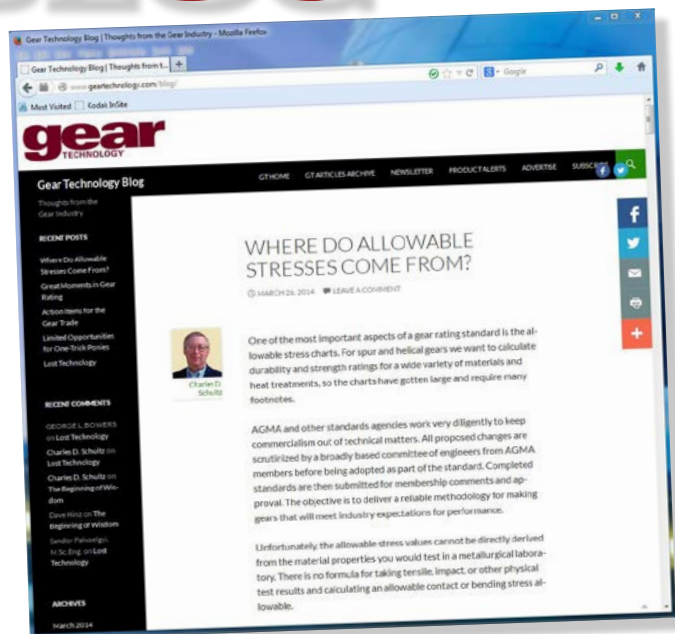

*More of what you're missing if you're missing Chuck:*

**On "Faydor Litvin: 100 Years a Genius":** My last posting talked about finding a book by Professor Faydor L. Litvin in my electronic files. In the preface to the book, professor Litvin laments that many of the personages he wrote about were not recognized for their contributions during their lifetimes. Some of them remained unknown long after their deaths. We still don't know who first accomplished many important feats in our trade. Those who wrote books, filed for patents, taught at prominent universities, or founded companies have a better chance of being remembered. But how would you rank achievers in a field with a history going back several thousand years? Do an innovator, inventor, and founder of several still-existing companies like George Grant get more consideration than an Iron Age mill builder?

We at Gear Technology are thankful that Professor Litvin has been recognized for his achievements within his lifetime and encourage readers to become familiar with his writings.

**On "Frequently Asked Questions (and Other TLA or FLA) Gear A.C.R.O.N.Y.M.s":**

The gear industry, like many others, has built up its own "lingo" that can baffle neophytes. I understand the Federal government has a manual devoted to the development of three-letter acronyms (TLA) and four-letter acronyms (FLA) to speed communication.

The situation in the gear industry is complicated by the different languages of our participating companies and the different descriptions we use for the same gear features. Somewhere in my files I have the valiant attempt of one group to assemble a "cheat sheet" of gear terms and abbreviations in six languages. It is "incomplete" at six pages.

(Check out Chuck's Blog every Monday, Wednesday and Friday at [geartechology.com](http://geartechology.com).) 



# Gear Grinding in Swiss Precision

Since Reishauer Switzerland invented Continuous Generating Gear Grinding, we have constantly been pushing the performance of our machines to new heights: Higher productivity – higher accuracy. That's why the leading automotive companies rely on Reishauer.



**Reishauer AG**

Zürich / Switzerland  
+41 44 832 22 11  
info@reishauer.com  
www.reishauer.com

**Reishauer Corporation**

Elgin IL / USA  
+1 847 888 38 28  
usa@reishauer.com  
www.reishauer.com

**REISHAUER**

Gear Grinding Technology

# PERFECT MATCH.

MAXIMUM ACCURACY SOLUTIONS  
FOR GEAR MANUFACTURERS  
BY KLINGELNBERG

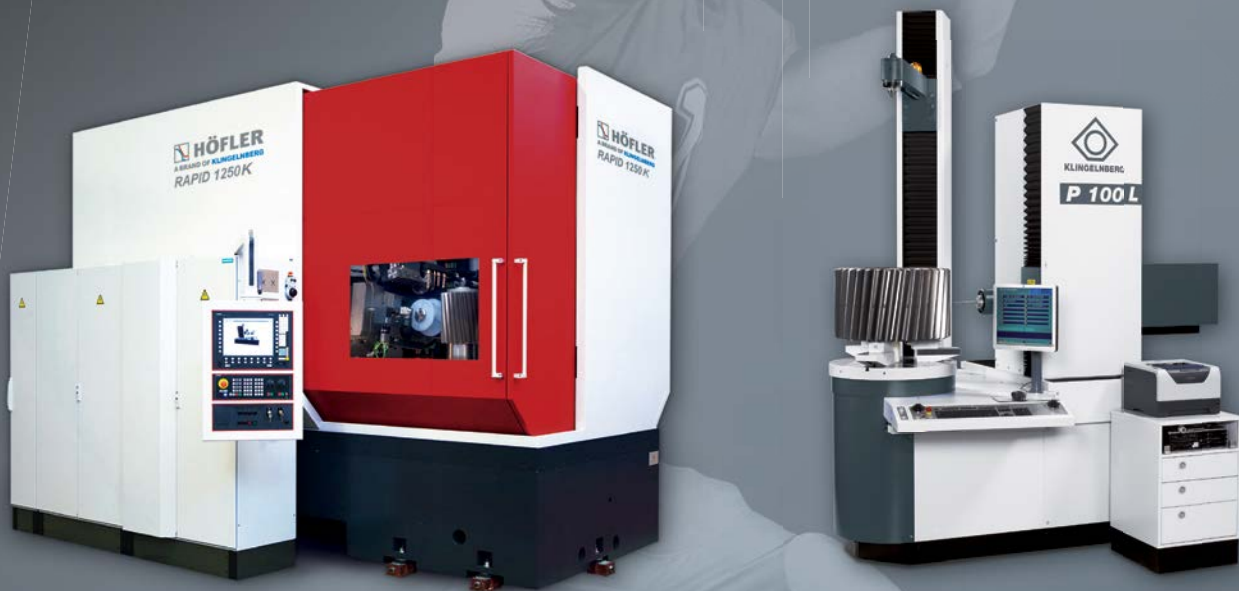

Only a perfect pass, a perfect catch and an optimal score make a perfect game. Such are Höfler gear grinders and Klingelberg measuring centers. For example the Höfler RAPID 1250K with a special spindle for smaller grinding wheels increasing your application range and the Klingelberg P 100L measuring center safeguarding highest precision – perfectly matched machines. A dream team within the Klingelberg system.

Become a player in cylindrical gear technology –  
with the perfect Klingelberg match.

Perfect Match:  
[www.klingelberg.com](http://www.klingelberg.com)  
[www.hofler.com](http://www.hofler.com)

KLINGELNBERG America, Inc.  
p. +1 734 470 6278  
e. [usa.sales@klingelberg.com](mailto:usa.sales@klingelberg.com)

#### NEXT FAIRS:



Control  
Hall 1 – Booth 1418  
Messe Stuttgart  
May 06-09, 2014  
Stuttgart, Germany



Metalloobrabotka  
Expocentre Fairgrounds  
June 16-20, 2014  
Moscow, Russia