

gear

TECHNOLOGY®



MAY
2016

100 YEARS OF GEARS

AGMA'S CENTENNIAL CELEBRATION

- ⚙️ Q&A WITH JOE FRANKLIN
- ⚙️ THE GEAR INDUSTRY NEEDS YOU
- ⚙️ MAKE VOLUNTEERING THE NORM

**MULTI-AXIS MACHINING IN
GEAR MANUFACTURING**

TECHNICAL

How to Make the Best Bevel Gears
Noise Reduction in an EV Hub Drive



Solutions for all your gear cutting tool needs

Gear cutting tools and services

Star SU offers a wide variety of gear cutting tools and services, including:

- Gear hobs
- Milling cutters
- Indexable Gear Milling Solutions by Sandvik Coromant
- Shaper cutters
- Scudding® cutters
- Shaving cutters
- Chamfer and deburring tools
- Rack and saw cutters

- Master gears
- Ring and plug gauges
- Advanced coatings including ALTENSA and ALCRONA PRO
- Tool re-sharpening

Total tool life cycle management

Control your tool costs and let Star SU manage your tool room. From new tools to design work to re-sharpening and recoating, we have the equipment and resources to help keep your gear cutting operation running smoothly.



SAMPUTENSILI

BOURN
& KOCH
INC

Phone: 847-649-1450

5200 Prairie Stone Pkwy. • Ste. 100 • Hoffman Estates • IL 60192



PTG-1L



GS 400

Affordable hob sharpening and in-house tool maintenance

Star's PTG-1L linear motor driven machine sharpens both straight and spiral gash hob designs up to 8" OD x 10" OAL. Additionally, it sharpens disk, shank and helical type shaper cutters, Scudding® cutters, and a wide range of round tools, making it a versatile tool room machine.

Shaving cutter and master gear grinding

Designed to grind shaving cutters and master gears, the GS 400 sets new standards for precision, reliability and ease of use. An integrated measuring unit automatically checks the quality of the first tooth ground without unclamping the workpiece.



System technology from one source
www.star-su.com



38



28

features

24 **The End of An Era — Joe Franklin's Valedictory**

AGMA President Joe Franklin is Stepping Down after 24 years on the Job.

28 **Off-Highway Endures Soft Markets**

Outlook Not Yet Truly Grim — but Companies are Scaling Back.

38 **All-For-One, One-For-All.**

Advantages of Multi-Axis Machining in Gear Manufacturing.

technical

30 **Ask The Expert**

Two Idler Gears?

44 **Noise Reduction in EV Hub Drive Using Full Test and Simulation Methodology**

A series of tests and advanced simulation to troubleshoot and optimize an EV hub drive for noise reduction is presented.

54 **(Stadtfeld's) Rules for Optimal Basic Design of Bevel Gears**

Making the Best Bevel Gears.

Vol. 33, No. 3 GEAR TECHNOLOGY, The Journal of Gear Manufacturing (ISSN 0743-6858) is published monthly, except in February, April, October and December by Randall Publications LLC, 1840 Jarvis Avenue, Elk Grove Village, IL 60007, (847) 437-6604. Cover price \$7.00 U.S. Periodical postage paid at Arlington Heights, IL, and at additional mailing office (USPS No. 749-290). Randall Publications makes every effort to ensure that the processes described in GEAR TECHNOLOGY conform to sound engineering practice. Neither the authors nor the publisher can be held responsible for injuries sustained while following the procedures described. Postmaster: Send address changes to GEAR TECHNOLOGY, The Journal of Gear Manufacturing, 1840 Jarvis Avenue, Elk Grove Village, IL, 60007. Contents copyrighted ©2016 by RANDALL PUBLICATIONS LLC. No part of this publication may be reproduced or transmitted in any form or by any means, electronic or mechanical, including photocopying, recording, or by any information storage and retrieval system, without permission in writing from the publisher. Contents of ads are subject to Publisher's approval. Canadian Agreement No. 40038760.

The Specialists

KAPP NILES machines efficiently finish-grind your critical gears and profiles with an accuracy of one thousandth of a millimeter, and a diameter of up to eight meters, to the utmost precision and durability.



from small to large

Generating Grinding 8mm- 1,250mm • Profile Grinding 8mm- 8,000mm



KAPP Technologies

2870 Wilderness Place Boulder, CO 80301

Phone: (303) 447-1130 Fax: (303) 447-1131

www.kapp-niles.com info-usa@kapp-niles.com



KISSsoft
Calculation programs for machine design

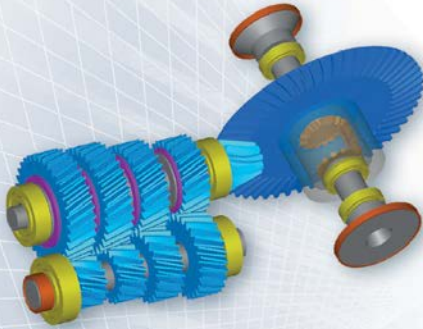

NEW
Release
03/2015

KISSsoft Highlights

- Risk assessment of flank fracture for cylindrical gears
- Contact analysis for bevel gears
- Planet carrier deformation with FE calculation
- Housing stiffness in KISSsys
- Modal analysis of shaft systems
- And many more ...

KISSsoft USA, LLC
3719 N. Spring Grove Road
Johnsburg, Illinois 60051
Phone (815) 363 8823
dan.kondritz@KISSsoft.com

Get your free trial version at
www.KISSsoft.com

gear
TECHNOLOGY® Vol. 33, No. 3

departments

- 06 GT Extras**
Check out our GT Library and its 30 years' worth (more than 2,000) of technical articles; also, Basics: cutting tools.
- 09 Publisher's Page**
Happy Birthday AGMA!
- 12 Voices**
Dean Burrows: The Gear Industry Needs You
- 14 Voices**
T.J. "Buzz" Maiuri: Make Volunteering the Norm
- 18 Product News**
Gleason 500CB Inspection Machine; Big Kaiser Milling Chuck; Saint Gobain NQ3 Grinding Wheels...
- 64 Industry News**
AGMA names Croson president; other news of note
- 68 Calendar of Events**
May 23-26: Windpower 2016
June 5-8: Powdermet 2016
June 27-29: Made by Klingelberg Gear Seminar/ WZL Gear Conference (See inside for details.)
- 69 Subscriptions**
Sign up or renew your free subscription.
- 70 Advertiser Index**
How to find every supplier in this issue
- 72 Addendum**
Harvesting Motion Power

Spiral Bevel Gears

- Spiral & straight bevel gear manufacturing.
- Commercial to aircraft quality gearing.
- Spur, helical, splined shafts, internal & external, shaved & ground gears.
- Spiral bevel grinding.
- Midwest Transmissions & Reducers.
- ISO compliant.



Midwest Gear & Tool, Inc.
15700 Common Rd., Roseville, MI 48066
Tel: 586.779.1300 midwestgear@sbcglobal.net



Liebherr Performance.



New design possibilities for the micro gear geometry

- The same torque at smaller face width
- Noise reduction

Economical solutions by generating grinding of modifications of the flank

- **TF** – Twist-Free
- **DFT** – Deviation Free Topological
- **NEO** – Noise Excitation Optimized modification
- **GER** – Generated End Relief
- Dresser independent profile modifications

Liebherr Gear Technology, Inc.
1465 Woodland Drive
Saline, Michigan 48176-1259
Phone.: +1 734 429 72 25
E-mail: info.lgt@liebherr.com
www.liebherr.com

LIEBHERR

THE GEAR INDUSTRY'S INFORMATION SOURCE

www.geartechnology.com

Unlock the Vault

The GT Library offers more than 2,000 technical articles published in the last 32 years as well as historic profiles on companies like Gleason "Hub of the Gear Industry," (www.geartechnology.com/articles/0115/Hub_of_the_Gear_Industry), Klingelnberg "The Latest Gear Generation," (www.geartechnology.com/issues/1013x/jan_klingelnberg.pdf) and Samputensili "Gear Sample," (www.geartechnology.com/issues/0114x/antonio-maccafferri.pdf).



GT Featured Topics

The *Gear Technology* homepage (www.geartechnology.com) features an in-depth collection of more than 32 years of technical content. Articles are indexed by subject, so all you have to do is type what you're looking for in the search bar.

This Month's Highlighted Topics:

- Basics**
- Cutting Tools**

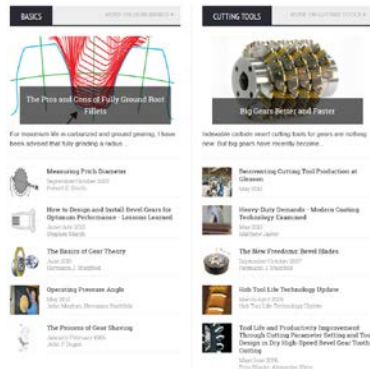

Gear Talk

Gear Technology technical editor and resident blogger Chuck Schultz weighs in on some important gear topics:

In *Slow Times Don't Last*, Chuck discusses his optimism for the construction equipment market and the need to get many infrastructure projects going in the United States.

In *Observations on Health Care*, Chuck examines the much maligned health care industry after scheduling a minor surgical procedure.

Stay Connected



Follow us on Twitter
twitter.com/#!/Gear_Technology



Connect with us on LinkedIn
www.linkedin.com/groups/Gear-Technology-Magazine-3893880



Subscribe Online
www.geartechnology.com/subscribe.htm

gear TECHNOLOGY

RANDALL PUBLICATIONS LLC
1840 JARVIS AVENUE
ELK GROVE VILLAGE, IL 60007
(847) 437-6604
FAX: (847) 437-6618

EDITORIAL

Publisher & Editor-in-Chief

Michael Goldstein
publisher@geartechnology.com

Associate Publisher & Managing Editor

Randy Stott
wrs@geartechnology.com

Senior Editor

Jack McGuinn
jmcguinn@geartechnology.com

Senior Editor

Matthew Jaster
mjaster@geartechnology.com

News Editor

Alex Cannella
alex@geartechnology.com

Editorial Consultant

Paul R. Goldstein

Technical Editors

William (Bill) Bradley, Robert Errichello, Octave Labath, P.E., John Lange, Joseph Mihelick, Charles D. Schultz, P.E., Robert E. Smith, Mike Tennutti, Frank Uherek

DESIGN

Art Director

David Ropinski
dropski@geartechnology.com

ADVERTISING

Associate Publisher & Advertising Sales Manager

Dave Friedman
dave@geartechnology.com

Materials Coordinator

Dorothy Fiandaca
dee@randallpublications.com

China Sales Agent

Eric Wu, Eastco Industry Co., Ltd.
Tel: (86)(21) 52305107
Fax: (86)(21) 52305106
Cell: (86) 13817160576
eric.wu@eastcotec.com

ON-LINE

Digital Content Manager

Kirk Sturgulewski
kirk@geartechnology.com

CIRCULATION

Circulation Manager

Carol Tratar
subscribe@geartechnology.com

Circulation Coordinator

Barbara Novak
bnovak@geartechnology.com

RANDALL STAFF

President
Michael Goldstein

Accounting
Luann Harrold



Extraordinary People Make the Difference



*Kevin Chatfield
Gear Grinding Leadperson*

We bought a \$1.5 million Grinder just for Kevin

New gear machines don't come cheap. But they're worth nothing without highly qualified, deeply experienced people to operate them. That's why we invest in the best – both machines and people. This new Reishauer is already increasing gear grinding output by tenfold in our new 'make complete' facility. But it wouldn't be possible without people like Kevin Chatfield, who applies 28 years of invaluable experience to every job.

Advanced technologies and experience. The best of both, at Forest City Gear.

Excellence Without Exception



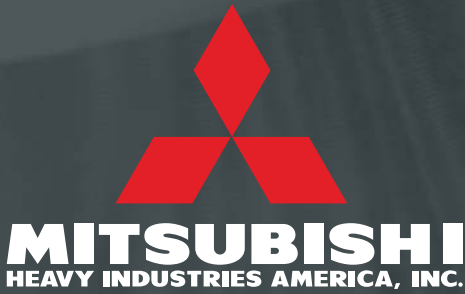

MITSUBISHI
HEAVY INDUSTRIES AMERICA, INC.

Our Technologies, Your Tomorrow

CNC Gear Machine Programming: Easy as 1-2-3

1

Input Gear Data from process sheet or part print. Input distance from work table to bottom of gear.

PARAMETER	VALUE	UNIT
NORMAL MODULE	3.000	
GEAR PRESS. ANG.	20.0000	°
GEAR LEAD ANG.	25.0000	°
HOBBING PATTERN	1	
ROB SPEED	430	
AXIAL FEEDRATE	0.0000	
RADIAL FEEDRATE	0.0000	
ROB/PORT CLEAR	1	
AXIAL FEEDRATE2	0.0000	
RADIAL FEEDRATE2	0.0000	
FINISH FEED	0.0000	
TOOTH THINNING	NO	

2

Input Cutter Data from cutter drawing or box.

PARAMETER	VALUE	UNIT
CUTTER NUMBER	1	
HOBBING PATTERN	1	
ROB SPEED	430	
AXIAL FEEDRATE	0.0000	
RADIAL FEEDRATE	0.0000	
ROB/PORT CLEAR	1	
AXIAL FEEDRATE2	0.0000	
RADIAL FEEDRATE2	0.0000	
FINISH FEED	0.0000	
TOOTH THINNING	NO	

3

Cutting speeds and feeds automatically calculated as well as cutter paths.

COORDINATE	VALUE
X	-3.0768
Y	4.4883
Z	-6.2345
A	-22.530
C	227.884

Advanced Gear Cutting Capabilities at Your Finger Tips

The many-generations-improved Mitsubishi CNC gear cutting machine simplifies programming like never before. It features Conversational Programming with built in macros for calculating cutting speeds and feeds based upon material hardness and gear class with no need to know complicated G-code programming like traditional CNC machine tools. Easy to understand graphics and help screens allow new operators to master programming within a day after installation—and shops that have never cut a gear before can quickly cut their teeth and expand production.

For more information visit mitsubishigearcenter.com or contact Sales at 248-669-6136.

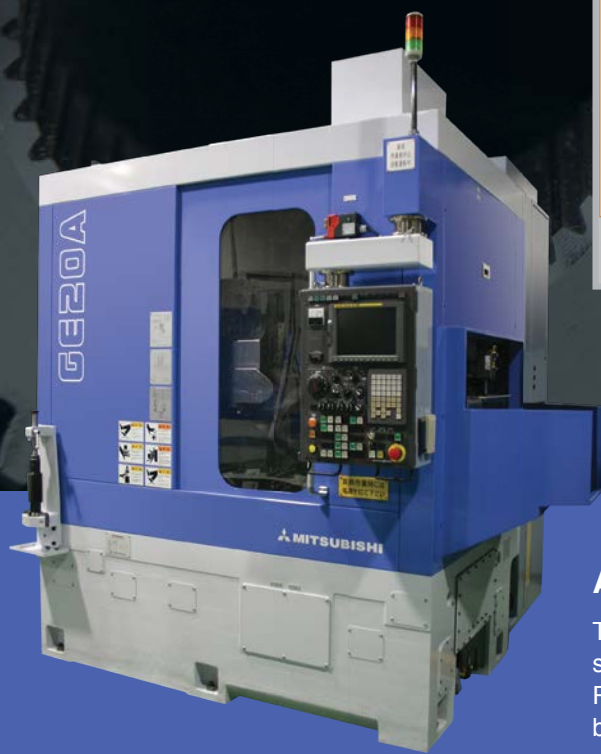

Happy Birthday!

The 25th anniversary is the silver. The 50th is the gold. The 75th is the diamond. But what symbolizes the 100th?

I wanted to know, because the American Gear Manufacturers Association (AGMA) turns 100 this year, and that's an anniversary worth celebrating. From its beginning, AGMA has been an important part of our industry's success, and it continues to be so today.

A brief history: In the early 1900s, industrialization caused an explosion in the requirements for all types of machined components, including gears. Nearly one million cars were sold in 1915, but the lack of industry-wide gear standards meant individual companies developed unique gears to suit particular applications, without any concern for interchangeability. This proved especially unwieldy for the U.S. military. By 1916, the U.S. government called upon the gear industry to create standards that would define gear types, tooth sizes, tolerances (quality), and manufacturing processes.

Nineteen companies answered the call, becoming the founding members of AGMA:

- Nuttall Gear (then part of Westinghouse Electric, now part of Altra Industrial Motion)
- Cincinnati Gear (the predecessor to today's Cincinnati Gearing Systems)
- Earle Gear (now part of Steward Machine Co.)
- Horsburgh & Scott



Publisher & Editor-in-Chief
Michael Goldstein

- Newark Gear Cutting Machine Company
- Philadelphia Gear (now part of Timken)
- Simmonds Manufacturing
- Van Dorn & Dutton
- Pittsburgh Gear (which became part of Brad Foote Gear Works, currently part of Broadwind Energy)
- Bilgram Machine Works
- Boston Gear (now part of Altra Industrial Motion)
- Crofoot Gear Works (now Tracey Gear & Precision Shaft)
- Foote Bros. Gear & Machine (now part of Regal Beloit)
- William Ganschow Company
- Gleason Works
- Hamilton Gear & Machine (now Standard Machine, a division of Timken)
- D.O. James Manufacturing (now Overton Chicago Gear)
- W.A. Jones Foundry & Machine (now part of Regal Beloit)
- Meisselbach-Catucci Mfg. Co.

These details and many more are included in AGMA's 100th Anniversary commemorative book, which I've had the opportunity to preview. The book describes not only the history of the AGMA, but also the history of the gear industry over the past century. You can follow this hundred-year journey by purchasing a copy of this beautiful book from AGMA. The cost is only \$20, and all proceeds go to the AGMA Foundation. You can order one by contacting foundation@agma.org.

But, it's more than the publication of the book and the 100th anniversary of the association that excites me. AGMA itself is undergoing one of the largest transformations in its history, and the next few years will likely be pivotal in determining whether the next 100 years will be as successful for AGMA as the first 100.

Joe Franklin, AGMA's president for almost 25 years, is retiring after the association's annual meeting (May 12-14 in Florida). During his tenure, Joe has brought a great deal of profes-

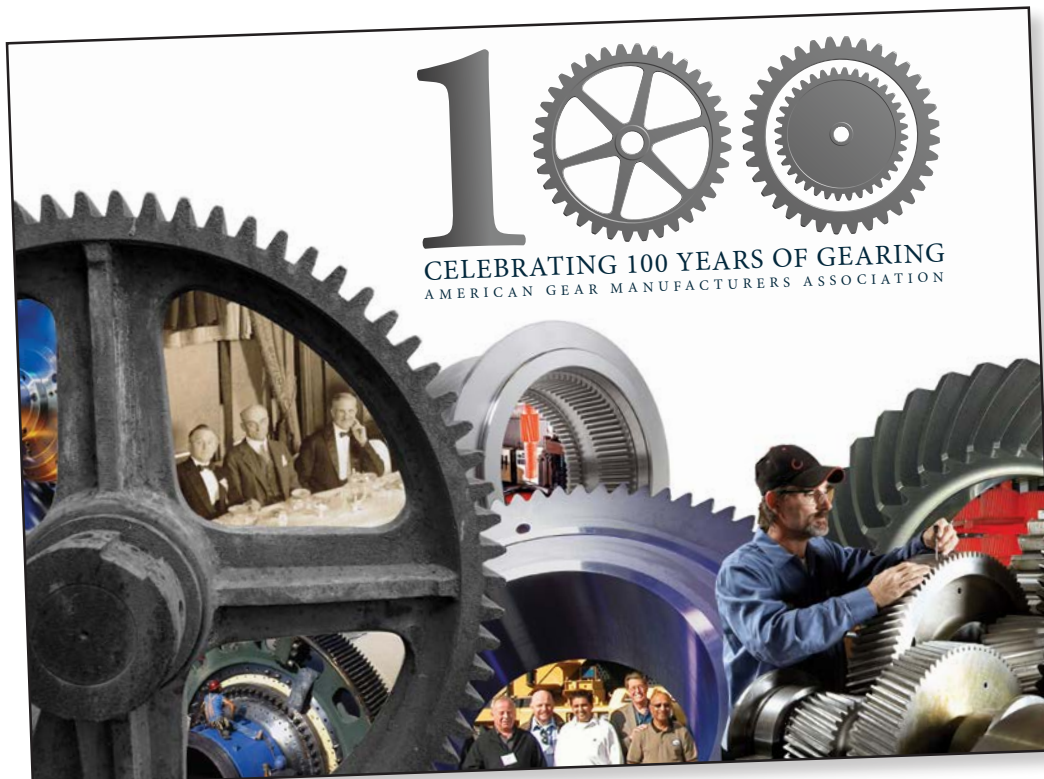

SEAMLESS ROLLED RINGS

& ALL OPEN DIE FORGED PARTS



**ALL PARTS ROUGH
MACHINED
100% UT TESTED**

**108" MAX O.D.
6" MIN O.D.
UP TO 55,000 LBS**

ISO9001:2008 / AS9100C

**All Metals &
Forge Group**

STEELFORGE.COM

800.600.9290

973.276.5000

Proud Sponsor of

**MANUFACTURING
TALK Radio**
 The Voice of Manufacturing - Globally

**BREAKING MANUFACTURING
NEWS, TRENDS AND INSIGHT
LIVE EVERY TUESDAY AT
MFGTALKRADIO.COM
PODCAST ARCHIVED**

sionalism to the association, overseeing a period of tremendous growth, not just in membership, but also in AGMA's impact on the industry. He leaves knowing that his tenure has been a great success. You can read our interview with Joe beginning on page 24 of this issue.

Not only has Joe brought a high level of professionalism to his own office, but he has surrounded himself with excellent people of a similar caliber. AGMA has a younger group of dedicated, smart and capable employees that are bringing new ideas and new energy to the association and the industry. Gear Expo has blossomed into one of the most important events in the world focusing on the gear industry itself, both for suppliers to the industry but also for the gear manufacturers, under the excellent guidance of Jenny Blackford. Our technical standards and representation at ISO were moved forward in giant steps, by Bill Bradley, followed by Charlie Fischer (both now retired) and now in the capable hands of Amir Aboutaleb, with the help of Justin Sikorsky. The AGMA Foundation has grown with the assistance of Cindy Bennett. Casandra Blassingame, who took over as Director of Education for the recently retired Jan Alfieri, brings solid experience and a fresh perspective to the educational offerings of AGMA. Jill Johnson with member services, Madelaine Morgan with meetings and Amy Lane's technical editing all mirror this excellence.

Just recently, AGMA has announced that Joe Franklin's replacement as AGMA president will be Matthew Croson. I haven't met him yet, but I hope he has big feet, as he's stepping into some very big shoes. What I do know is that Croson has more than two decades of manufacturing trade association experience, and who most recently was president and CEO of the Adhesive and Sealant Council.

But the influx of new, experienced and energetic leadership doesn't stop there. AGMA's chairman is the capable and relatively young Dean Burrows, president of Gear Motions, who is just beginning his second year as chairman. More importantly, Dean has experience both inside and outside our industry, and that perspective brings new ideas, new insight and a new vision for where our association and our industry can and will be going in its second century. Dean offers some of his perspective in his *Voices* column on page 12.

If you're an AGMA member, this 100th anniversary celebration is going to be an event you don't want to miss. If you're not an AGMA member, you're missing an opportunity not only to participate in helping direct the future of your industry, but also to avail yourself and your employees of the many benefits of membership, some of which are talked about in Buzz Maiuri's piece, beginning on page 14.

Oh, and it just came to me. If the 75th is diamond, the 100th must be the gear anniversary. So happy 100th birthday AGMA — have a great and successful centennial celebration.





GMTA NOW REPRESENTING

RASOMA

Werkzeugmaschinen GmbH

GERMAN MACHINE TOOLS OF AMERICA (GMTA) is now the authorized North American representative for **Rasoma**, a builder since 1919 of high-quality vertical turning centers, 4-axis shaft turning centers, end machining centers, double-spindle machining centers and a variety of automated solutions for the automotive and other industries.

The addition of **Rasoma** to our other lines makes **GMTA** a viable partner for nearly every application in the powertrain, gearmaking, bearing and other production line concepts for auto, motorcycle and off-road vehicles, as we bring full application engineering, machine building, laser integration and commissioning to your facility, with single-source support and service from our plants in Ann Arbor, Michigan and Queretaro, Mexico.

Take a look at **Rasoma** and all our lines at www.gmtamerica.com. You'll be glad you did.

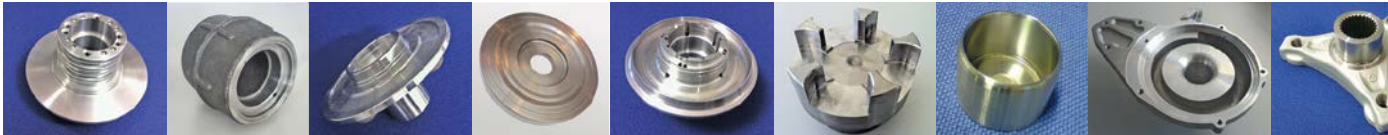

Call Scott Knoy
today for all the details.
734-973-7800



Ann Arbor, Michigan | Queretaro, Mexico | www.gmtamerica.com | Email: company@gmtamerica.com

The Gear Industry Needs You

Dean Burrows



Every major milestone in your life and in your professional career is an inflection point for you to take stock of where you came from and where you are going.

This is no different for an organization like the American Gear Manufacturers Association. As AGMA celebrates its centennial in 2016, it is an appropriate time for the organization to look back at the individuals and companies who brought the organization from its inception through its formative years to become the renowned global association it is today. The individuals and companies who have dedicated themselves to the AGMA are too numerous to name, and the contributions they have made through the first 100 years have been truly invaluable to the organization's continued growth and success. Their commitment over the years and their willingness to share their time, talent, and treasure has made AGMA what it is today.

As a global organization with almost 500 members, with over 25 percent international, AGMA continues to lead the global gear industry while remaining rooted in the technical standards that AGMA was founded to create. As we look to the next 100 years, we will use our strong foundation to envision a future that moves the AGMA to heights that our 19 original founding members could have never imagined.

Joe Franklin has led AGMA for the past 25 years and has grown it to be the world's premier gear association. His contributions cannot be put into words, but can be seen through the continued success of the organization over his tenure. As we embark on this new journey with a new President, Matt Croson, we seek to chart a path that continues to honor our traditions and build on the success of technical documents, networking, and educa-

tion, while exploring new areas such as emerging technologies and advocacy. We are also committed to adding more value to our global members through education specifically tailored to members' needs in their respective countries.

With a seasoned, professional staff leading the organization at our headquarters in Alexandria, Virginia, the AGMA continues to stride forward, but as with any organization, there are challenges that we face. Engaging our members to volunteer their time, talent, and treasure has become increasingly more difficult as companies and individuals face more time and financial constraints. Therefore, we need to find new and innovative ways to engage our members and encourage their involvement with the AGMA. The benefits and rewards of involvement through serving on technical committees, business committees, and ultimately the board of directors need to be voiced to our members. As leaders, we need to identify those individuals within our organizations that can help the AGMA, and as a result, our businesses, move forward and succeed. When the AGMA helps the global gearing industry advance, it contributes to the success of all our members. At this time, we need our company leaders to make a personal commitment to help the AGMA help them.

So what is the value proposition for your company? How will your company and your most valuable asset, your employees, be better off for participating in AGMA? From personal experience at Gear Motions, our involvement began in the early 1970s. Over the years, our employees have attended the Daley Gear School, participating in online training/webinars, participated on technical committees, and brought this knowledge back to the day-to-day business of running our employee-owned busi-

ness. The costs associated with participation in AGMA are far outweighed by the benefits it has brought to Gear Motions. We are a stronger company through our involvement at all levels of AGMA.

As we enter the next century of the AGMA's leadership in the gear industry, the long-term view for the organization and the industry as a whole remains bright. The industry and AGMA's members will always have challenges and rough times, but we can continue to ultimately survive and prosper. The AGMA has supported its members and made invaluable contributions to the industry for the past 100 years and will continue to do so for the next 100 years and the 100 after that. 

Dean Burrows is

beginning his second year as chairman of the board of AGMA. He is also president of Gear Motions. Burrows joined Gear Motions in 2008 as president of Nixon Gear. He graduated with a Master's in engineering management and a B.S. in industrial engineering from the Rochester Institute of Technology. He previously served as vice president of operations for Marietta Corporation in Cortland and director of global supply chain for Carrier Corporation, a Division of United Technologies. He has more than twenty-five years of operations experience from various industries including automotive, medical device and consumer products.



WE ARE
A TEAM WHOSE END
GAME IS COMPLEX
PROJECTS, INCREASED
PROFITS, AND JOB
CREATION. IMTS WILL
HONE OUR GAME PLAN
WITH BIG IDEAS AND
NEW EQUIPMENT.

WE ARE

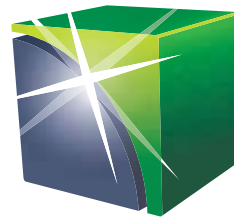

COMPETITIVE.

Matt Guse
President & Owner, MRS Machining

IMTS2016

International Manufacturing Technology Show
September 12 - 17, 2016 · McCormick Place · Chicago

REGISTER TODAY AT IMTS.COM/REG

Make Volunteering the Norm

Thomas J. "Buzz" Maiuri



This is a very exciting year for AGMA as the organization celebrates its 100-year anniversary. In addition to the anniversary, AGMA President Joe Franklin, jr., who has done an outstanding job at the helm of AGMA for the last 25 years, will retire, and we welcome in our new AGMA President, Matt Croson, who will lead us into the next 100 years. The centennial kicked off in October with a dinner at the AGMA Gear Expo in Detroit and will continue throughout 2016 with a number of exciting events scheduled to celebrate this milestone anniversary. The celebration will come to a conclusion at the 2016 Fall Technical Meeting in Pittsburgh, PA, the city where the first AGMA meeting was held 100 years ago.

AGMA is about a number of things, and one of the most important elements of the organization is the Technical Division. The Technical Division consists of the Technical Division Executive committee (TDEC) and the 25 technical committees, including two active sub-committees. The committees create and maintain the standards and information sheets that the gear industry relies on every day. The TDEC has the responsibility to supervise the development and maintenance of all AGMA standards and technical publications. They also coordinate the Technical Division's activities with the activities of the Administrative Division of AGMA. Another important role of the TDEC is to organize and conduct the Annual Fall Technical Meeting. This year, the FTM will be held October 2-4 at the Sheraton Pittsburgh Hotel at Station Square in Pittsburgh, PA.

For more information on the roles of both of these groups within the Technical Division, please look up the article in *Gear Technology* from September of 2013 titled "How Gear Standards are Written." The article, as well as all past *Gear Technology* articles, can be found in the "GT Library" at geartechnology.com.

The TDEC consists of a chairman (myself — T.J. "Buzz" Maiuri of The

Gleason Works) and seven voting members: John B. Amendola, Sr. of Artec Machine Systems; Terry Klaves of Milwaukee Gear Company; Todd Schatzka of Rexnord Corporation; Todd Praneis of Cotta Transmission Company; Bill Hanks of A-C Equipment Services, and Walt Weber of Siemens Industry Inc. The newest member joining the TDEC is Michael He of Scot Forge Company. The TDEC schedules two to three face-to-face meetings and conducts several meetings via web conference each year. In addition to these scheduled meetings, we hold several impromptu conference calls and emails throughout the year to take care of any business that needs to be addressed between meetings.

All TDEC meetings are attended by AGMA Headquarters Technical Division personnel Amir Aboutaleb (vice president of the Technical Division) and Justin Sikorski (staff engineer). In addition to Amir and Justin, the president of AGMA, the chairman of the AGMA board of directors, and the chairman of the Business Management Executive committee (BMEC) attend the meetings as well.

The new chairman of the board of directors, who began his term in May of 2015, is Dean Burrows, president of Gear

evaluate new projects and prepare project proposals to the TDEC. They also submit progress reports, present completed projects for approval and report difficulties that the committee may be facing to the TDEC.

Amir and Justin, from AGMA headquarters, are actively involved with each of the committees. Each has his specific committees that he is a liaison to, and one of the two is in attendance at every technical committee meeting, whether it is a face-to-face meeting or a web conference.

The technical committees are responsible for the timely development, maintenance, and theoretical accuracy of the technical publications of AGMA. Each committee has a chairperson and a vice chairperson. Last year there were a total of 138 committee meetings — 17 meetings were face-to-face and 121 were held via web conference. The use of web conferences by committees is growing every year, which allows committee participation without the costs of travel and time out of the office.

The average committee meets about six times a year. Some committees may have only two or three meetings, while other committees have as many as 10 or 11 meetings per year. Last year there were 9 committees that met exclusively through web conferences.

The average committee has about 30 members, with about 10 of the committee members being active members. The Helical Gear Rating committee is the largest committee with over 70 members and 23 of the members considered active members. The remaining committee members are observer members. An active member is a representative of a member compa-

“No one starts out as an expert — it takes time and effort to acquire the knowledge, insight and experience. You must put yourself, or your employees, in a position or situation to obtain that knowledge and experience by working with others in your segment of the industry who have different experiences and challenges.”

Motions, Inc. John Cross, president of ASI Technologies, Inc. is the chairman of the BMEC.

Each member of the TDEC has the responsibility of being the liaison to several of the technical committees. The liaisons help the committee chairpersons

ny that regularly attends meetings, and accepts and performs work assignments as assigned by the chairperson. All new committee members start as observer members. An observer member cannot vote on committee actions, but may participate in committee activities and receives committee distributions, such as meeting minutes and agendas. Based on attendance and contribution levels, an observer member may submit a request to the committee chairperson for their status to be changed from observer to active.

At this time committees are working on roughly 30 open projects. AGMA committees have responsibility for a total of 98 documents consisting of 55 AGMA Standards, 33 AGMA Information Sheets, six Adopted ISO Standards, and four Adopted ISO Technical Reports.

All AGMA standards have the status of being American National Standards as defined by the American National Standards Institute (ANSI). To maintain this status, AGMA's Technical Division procedures are audited by ANSI every five years to ensure compliance with our own Policy and Practices and with ANSI's requirements. The last audit was in 2014, and the next will be in 2019.

Several of the technical committees also have the responsibility to serve as the United States Technical Advisory Group to Working Groups (WG) within ISO TC 60 and ISO TC 14 (International Organization for Standardization — technical committees). AGMA is the secretariat of ISO TC 60 and procedurally oversees all the standards programs that are undertaken by TC 60. The scope of ISO TC 60 is standardization in the field of gears, including terminology, nominal dimensions, tolerances, and tools for manufacturing and control. The scope of ISO TC 14 is standardization in the field of shafts for machines, their keys and keyways, splines and serrations and their accessories such as couplings and flanges.

AGMA publishes two types of documents: standards and information sheets. While similar, information sheets and standards have several key differences. AGMA standards comprise proven, time tested information and require compliance to all guidelines provided except where specific exceptions are

clearly recorded. Information sheets often contain material that is not yet common practice and is still in the process of being proven. Information sheets are often a forum for setting new material before the industry so that it can be used and refined.

All AGMA standards require balloting before the entire membership of AGMA, as well as any other interested parties. An information sheet requires only approval of the technical committee that prepared it and permission to pub-

lish from the TDEC. Not going through a General Ballot allows an information sheet to be published more quickly; however, information sheets do not carry the same authority of consensus standards.

So what are the benefits to an individual serving on an AGMA technical committee?

For me personally, it has been a great experience. In 2001 I was asked to serve on the TDEC and I confess I was a little anxious because I had no idea what I was





LFG-8040 VERTICAL GEAR PROFILE GRINDING MACHINE

**800mm-50mm CNC Smart Gear Grinding
With Hob Sharpening Capabilities**





- ◆ Fanuc controller
- ◆ Direct drive motor
- ◆ 8-axes closed loop system
- ◆ On-board inspection
- ◆ Automatic stock dividing
- ◆ AGMA Class 14 or DIN 4
- ◆ Luren designed windows based smart grinding operating software
- ◆ Up to 1000 mm grinding with tail stock removed
- ◆ 800 mm with tailstock

Our Gear Cutting Tools *Hobs • Shaper Cutters • Master Gears*



For over 20 years Luren has manufactured high quality, high precision gear cutting tools using the very best materials to ensure long tool lives and very satisfied customers.



Corporate Headquarters
Luren Precision Co., Ltd.
 No.1-1, Li-Hsin 1st Road,
 Hsinchu City, Taiwan, 30078
Phone : +886-3-578-6767
Email : sales@luren.com.tw
Website : www.luren.com.tw

North American Headquarters
Luren Precision Chicago Co., Ltd.
 707 Remington Road, Suite 1,
 Schaumburg, IL 60173, U.S.A.
Phone : 1-847-882-1388
Email : sales@lurenusa.com
Website : www.lurenusa.com



Hall C4 Booth #2128



North Building Booth #N-6960

Quality Solutions Since 1960



Standard Components, Made To Print Parts And Assemblies

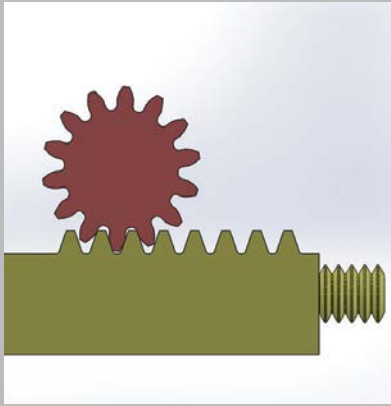

- Mechanical Components and Assemblies
- Made to Print Parts
- Design & Engineering

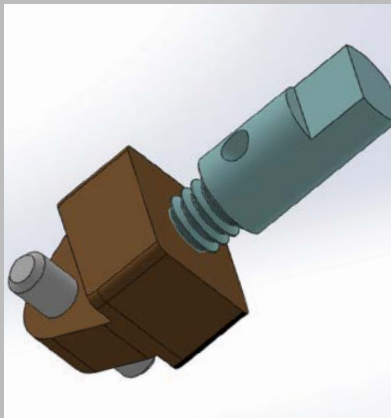

Nordex.com

sales@nordex.com

eng@nordex.com

Phone: (800) 243-0986
or Call: (203) 775-4877

getting myself into. I did not know any of the TDEC members prior to the meeting and I honestly did not know that much about the AGMA organization. I quickly realized that my anxiety was for nothing. At the very first TDEC meeting, I was warmly welcomed and made to feel part of the team right out of the box. Over the years I have had the opportunity to meet numerous men and women from the world of gearing. These people are the heart of the industry — they are the managers, salesmen, gear designers, machine designers, application engineers, manufacturing engineers, professors, owners, etc.

My involvement with AGMA and the people I have met and worked with over the years has been of great benefit to me. The experience gained working alongside people from other organizations has helped me further develop relationships with my coworkers. In many instances I have been able to help our customers by

AGMA and the support of my company The Gleason Works.

No one starts out as an expert — it takes time and effort to acquire the knowledge, insight and experience. You must put yourself, or your employees, in a position or situation to obtain that knowledge and experience by working with others in your segment of the industry who have different experiences and challenges. Often, you will find there are different ways to do things, or think about things — not necessarily better, but different. A good place to start or expand that knowledge and experience is by participating with AGMA. Working on an AGMA committee is not a chore or obligation; it's an opportunity.

A colleague of mine told me a story about a young engineer from a number of years ago who was just starting out as a new employee for his company. He joined an AGMA committee, and was tasked with doing some research and

“Over the years I have had the opportunity to meet numerous men and women from the world of gearing. These people are the heart of the industry—they are the managers, salesmen, gear designers, machine designers, application engineers, manufacturing engineers, professors, owners, etc.”

calling on the many contacts I've made to just chat and get a better understanding of a particular issue or subject. It also works the other way — I'll get calls from contacts and colleagues or even individuals that I have not met, asking for some insight or contacts that can provide further assistance.

One of the highlight experiences of my career came last year at a dinner hosted by *Gear Technology* magazine during the AGMA Gear Expo. I was seated in a room with over 20 individuals from all over the world who are known as the top experts in the world of gearing. I can't mention all their names here, but I will tell you it was like a hockey fan being in the same room with Gordie Howe, Wayne Gretzky, Mario Lemieux, Bobby Orr, Tony Esposito, Bobby Hull, Mark Messier, and Stan Mikita - just to name a few. This would not have been possible for me if not for my involvement with

exploring the subject matter of the information sheet/standard the committee was working on. That young engineer eventually reached the position of Vice President of Engineering. It was clear that the research and investigation he did for the committee had played a large part in his becoming the expert and to his becoming the engineering manager.

I asked new committee members who have been participating on a committee for just over a year about their thoughts and experiences. They have attended several face-to-face meetings and a half dozen web conferences. Their first comment was on what a great networking experience it has been. They have met experts from around the industry and have benefited from “getting outside and seeing the industry from different viewpoints.” Joining while the committee was in the middle of writing a new standard provided an interesting look into how

and what information gets included in a standard, and the discussion of how best to present it.

When I asked the same question of a veteran committee member who has been serving on a committee for almost 20 years, he responded that he has gained a much deeper and broader knowledge of his trade by working with experts from different sectors of the gear industry as compared to what he would have ever gained interacting only with coworkers and suppliers. He had also gained a number of contacts with great expertise in different areas that he has been able to draw on over the years.

So what are the benefits to member companies and management who allow their individuals to serve on an AGMA technical committee? Again, I posed that question to a manager who has several of his staff working on AGMA committees. He said that it is an opportunity for those individuals to be exposed to and contribute to technical discussions, which will broaden their understanding of the gearing industry as a whole.

AGMA technical committee participation is a great way for managers to help their employees meet the development goals the employee would like to achieve, as well as the development that the employer would like to realize in order to maintain a competitive technical department. In addition to the professional development that managers see, having representatives on the committee allows the member company to have a say in the development of the standards.

Since individuals serving on the technical committees and the TDEC are all volunteers from member companies, I would like to take this opportunity to thank everyone involved for the great job they are doing. Involvement in AGMA is a win/win opportunity for all involved — the individuals serving on the committees, the companies they are representing, and AGMA. There is no better way to learn about the standards, the art of gearing, and the gearing industry than participating on an AGMA technical committee. You do not have to be an expert to get involved, but I know that if you do participate on an AGMA technical committee, you will

be working alongside some of the most knowledgeable individuals in the world of gearing. In time, you can become the expert and be the mentor to the next generation of those joining the industry.

We are always looking for new people to participate on AGMA technical committees. If you are interested we encourage you to contact Amir Aboutaleb at aboutaleb@agma.org. 

T.J. “Buzz” Maiuri

Sr. Product/Project Manager — The Gleason Works
Chairman - AGMA Technical Division
Executive committee

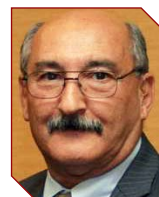

Gearing your past to power your future.

Breakdown Services
We understand the urgency of meeting critical deadlines. We offer our customers expedited services without sacrificing quality.

Heat Treatment
Our in-house heat treat facility performs a full range of services that include annealing, carburizing, and thru hardening.

**B&R**
MACHINE AND GEAR CORP.

B&R Machine and Gear Corporation is a full service gear manufacturing facility driven to power your equipment with reliable and durable gears that are built to perform and last. Find the perfect mesh. No matter the gear, we've got you covered.

VISIT OUR WEBSITE BRGEAR.COM FOR MORE INFORMATION

Gleason 500CB Inspection Machine

HELPS ACHIEVE PRECISE GEAR QUALITY AND MAXIMUM TOOL LIFE

Gleason Corporation has introduced its latest innovation, the 500CB Cutter Build Inspection Machine. The 500CB delivers more accurate and highly automated build, truing and inspection of all types of stick-blade bevel gear cutters.

The 500CB features automated closed-loop blade positioning creating a highly accurate and repeatable build quality. An accurately built cutter head is a critical factor in achieving precise gear quality and maximum tool life. In addition, the 500CB also automatically controls the tightening of the blade clamp screws, consistently applying the correct torque. These features require greatly reduced operator involvement to build highly accurate and repeatable cutter heads, while freeing personnel to perform other functions.

This advanced machine has an intuitive operator interface including “wizard” functions to guide an operator through the build process. The software has many smart features, making recommendations to the operator while continually displaying key data as the head is being built.

For more information:

Gleason Corporation
Phone: (585) 473-1000
www.gleason.com/500CB



Traub TNL32-11

PROVIDES THREE SIMULTANEOUS TOOLS

The new Traub TNL32-11 sliding/fixed headstock automatic lathe has a headstock moving in the z-axis, an upper and identical lower turret with x, y, and z-axes and a counter spindle movable in the x and z directions. It offers a new front working attachment which sits on an additional cross-slide moving in the x and z-axes, providing the user with further, freely positionable tools and enables the use of up to three tools simultaneously and independently of each other. The 11-axis machine saves machining time - especially for components with a high proportion of drilling.

In addition to the two linear x and z axes, the front working attachment features a CNC circular axis. By the interpolation of the rotary axis with the x-axis and the c-axis of the main spindle, the front working attachment can also be used in the y direction using an interpolated y-axis. The particular benefit: when a drilling tool needs to be corrected to exact center, the necessary corrections can be simply performed via the CNC controller. That can help with small parts which react with great sensitivity to even minimal offset errors.

The front working attachment makes eight additional tool stations available. Four of them are used to mount fixed tools, the other four are for live tools.

There is also a station for a workpiece gripper which can unload a machined workpiece from the counter spindle. While the finished workpiece is discharged from the counter spindle, the next part can be machined with two tools at the main spindle.

With an output of up to 3.4 kW and a maximum speed of 12,000 rpm, the tool drive in the front working attachment is extremely productive and designed for high power. The tool holders are highly robust and stiff with a mounting shank diameter of 36 mm. Individually control-





Another highlight is the “Dual Drive” consisting of two drive trains integrated within one turret. This patented drive solution reduces non-machining time and thus also machining times per piece. While one tool is in use, the tool intended for the next work step can be accelerated up to the desired speed during main time and is immediately available at full speed after the turret indexing operation. Jerky accelerations and delays that

were previously unavoidable when reducing auxiliary processing times are now prevented. In addition, tool holder wear is reduced due to the lower acceleration values. Even with live tools, chip-to-chip times are around just 0.3 seconds.

For more information:
 Index Traub
 Phone: (317) 770-6300
www.indextraub.com

able coolant pressure of up to 80 bar is available at every station. One live station can be used as a deep-hole drilling station with a coolant supply up to 120 bar. The front working attachment can also be used as a tailstock when producing long components.

In addition to the advantages of the front working attachment, the Traub TNL32-11 offers the many other benefits of the entire TNL series. The work area is easily accessible to the operator due to its high and wide sliding door, simplifying setup and changeovers. A large inspection window allows the operator to keep a close eye on the machining process. The long z travel of the headstock means the machine can easily be used for sliding or fixed headstock turning without compromises in less than 15 minutes.

Tool turret indexing is performed using an NC rotary axis that controls movement via an internally meshing planetary gear. This allows the turret to be indexed to any position without requiring a mechanical locking mechanism. The free positioning of the turret makes multiple-tool assignment possible on each station.

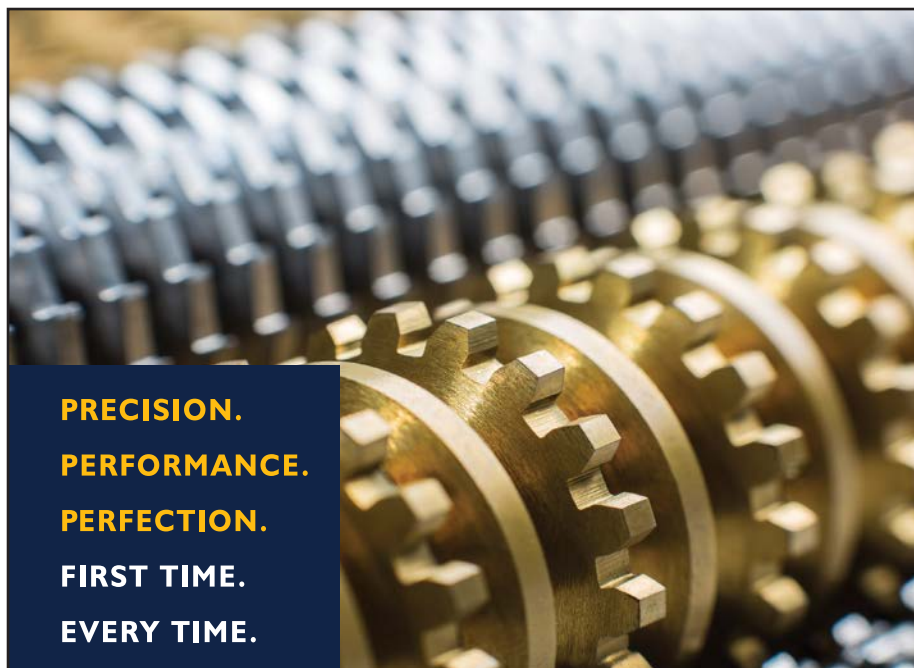

PRECISION.
PERFORMANCE.
PERFECTION.
FIRST TIME.
EVERY TIME.

Manufacturers of:

Broaches

- Spline Broaches
- Fine Pitch Gear Broaches
- Form Broaches
- Serration Broaches
- Bearing Cage Broaches

Shaper Cutters

- Disk Shapers
- Shank Shapers
- Hex and Square Cutters
- Special Form Cutters

Inspection

- Master Gears
- Go-No Go Gages
- Posilock Arbors
- “Quick Spline” Software



The Broach Masters
 and Universal Gear Company

1605 Industrial Drive
 Auburn, CA 95603
 Phone: (530) 885-1939
 Fax: (530) 885-8157

Call 530-885-1939 or visit
www.broachmasters.com

Suhner Rego-Fix

DIRECTLY APPLIES COOLANT-LUBRICANT TO IMPROVE TOOL LIFE

Rego-Fix has launched a cost-effective and efficient attachment for the application of coolant-lubrication liquids through a tool based on an ER collet nut, which is ideal for use on Suhner feed drilling units.

Optimizing the cooling and lubrication effect to help increase chip removal, tool life and performance requires the coolant-lubricant mix in direct contact with the cutting edge of the tool. Namely, for drilling operations, internal coolant has become more and more essential. In the past, the application of an internal pressurized coolant-lubricant mix, especially for quill feed units, presented challenges and complications.

A new approach engineered by Rego-Fix is called reCool, where the coolant-lubricant mix enters the collet from the radial direction and then passes through the tool. It is very simple and effective. Based on this idea, Suhner adapted the reCool principle and designed attachments

for the application of internal coolant liquids for its Monomaster and Multimaster families of quill feed drilling units.

Drilling with coolant through the tool applications typically allow for a 20 percent increase in surface cutting speed, which results in higher chip removal rates and reduces machine cycle time.

This solution allows users to retrofit Suhner quill feed units with internal coolant supply, even on existing machines in a clever, uncomplicated way, thus providing increased benefits in machine efficiencies and production time.

Some of the advantage of reCool are a simple retrofit for existing quill feed units, optimal cooling & lubricating at the tool, up to 20 percent higher surface speed, good chip removal, optimal lubrication for every tool and nonexistent deflection or dissolving of coolant.

ReCool is compatible with spindle speeds up to 12,000 rpm. It has a coolant pressure of 50 bar/725 psi and can be used for internal and external coolant application.

For more information:

Suhner Industrial Products Corp.
Phone: (706) 235-8046
www.suhner.com



Sumitomo Milling Cutter

OFFERS HIGH WEAR RESISTANCE, PRECISION AND EFFICIENCY



New from Sumitomo Electric Carbide Inc., the DFC Double-Sided 90° Milling Cutter is engineered for exceptional precision and efficiency.

The high toughness and special shape of the DFC six-edge insert ensure long-term, stable cutting and high efficiency machining with high feed rates. Cutting edges are optimized to provide excellent surface finishes.

Low cutting forces and high wear resistance of Sumitomo's DFC result in a long tool life. Machining accuracy is enhanced through the separation of the insert contact areas and cutting edges. In addition, a double-sided insert design reduces costs.

Recommended insert grades for steel include ACP200 and ACP300. For stainless steel applications, ACM200 insert grades are recommended and for cast iron applications, ACK200 and ACK300 insert grades are recommended.

The DFC is available in 1" to 8" in standard, fine pitch and extra-fine pitch styles for a variety of applications. Maximum depth of cut is 6 mm.

For more information:

Sumitomo Electric Carbide, Inc.
Phone: (800) 950-5202
Sumicarbide.com/milling_dfc.htm

Saint Gobain NQ3 Grinding Wheels

DECREASE DOWNTIME , IMPROVE USER COMFORT

Saint-Gobain Abrasives has introduced Norton Quantum3 (NQ3) Depressed Center Grinding Wheels. Featuring a proprietary grain along with a tougher bond system containing a combination of fillers and bonding agents that allow for better mix quality in manufacturing, NQ3 provides substantially faster grinding for more metal removal and longer wheel life with less operator fatigue to significantly increase grinding output. Test results conducted with NQ3 and competitive wheels revealed that NQ3 removed almost twice the amount of carbon steel at five minute intervals.

NQ3 wheels are constructed using a precisely engineered iron, sulfur and chlorine-free resin technology to provide a uniform abrasive distribution throughout the wheel. This unique bond was designed for retaining the grains long enough during and after grain fractures. This subtle but powerful bond characteristic enables both excellent cut rates and wheel life.

“Norton Quantum3 grain tends to be more rounded than precision-shaped

ceramic grain. This allows a more robust, sharper cutting action with less vibration, for much easier operator control. These wheels don't grab or dig when used in any direction. They simply glide through the workpiece while removing metal. This also means the free cutting control can boost the amperage on its own without additional pressure needed on the tool,” said Debbie Gaspich, Norton Abrasives director of product management, North America. “Norton Quantum3 grinding wheels are made in the USA and provide users the lowest total operating cost and the most productive grinding yield in the industry.”

The NQ3 wheels are offered in 12 Type 27 all-purpose grinding application SKU's, one Type 28 all-purpose and two Type 27 SKU's for foundry applications. All products are currently in stock. Sizes range from 4" x 1/4" x 3/8", to 9" x 1/4" to 7/8".

For more information:
Saint-Gobain North America
Phone: (610) 893-6000
www.saint-gobain-northamerica.com



DO YOU KNOW HOW YOUR BEVEL GEAR BLADE WAS MADE?

WE DO.



NOT ALL CARBIDE
IS CREATED EQUALLY.



MITSUBISHI
MITSUBISHI MATERIALS

Hard Materials Division | (800)-322-6382 | hardmaterials@mmus.com

Heimatec Live Tool Speed Multiplier

AVAILABLE IN STYLES UP TO 24,000 RPM

Heimatec has announced that its newest development, a line of 1:4 live tool speed multipliers in 24,000 rpm max. styles, is now available for all popular live tool lathes currently on the market.

These speed multipliers are provided as axial or radial drilling and milling heads, with either external or internal coolant design and mounting configurations to suit virtually any machine tool turret set-up, including all VDI and BMT sizes.

According to Heimatec President Preben Hansen, "As our presence in the American machine tool market continues to expand, so does our product line. These speed multipliers are a great addition to our line. They give us more to offer the job shop and large production departments, through our growing net-

work of reps and distributors, serving the market here."

For more information:

Heimatec Inc.
Phone: (847) 749-0633
www.heimatecinc.com



All The Gear Cutting Tools You Will Ever Need Are Right Here DTR is one of the world's largest producers.

DTR. Your best choice for high quality gear cutting tools.

DTR is a world class supplier of the finest high performance long-life gear manufacturing tools, for small and large gear cutting applications. Established in 1976, we are one of the world's largest producers of cutting tools, shipping to over 20 countries.

DTR offers a full line of gear cutting tools including:

- Hobs
- Carbide Hobs
- Shaper Cutters
- Milling Cutters
- Chamfering and Deburring Tools
- Broaches
- Master Gears

We can produce virtually any tool you need for auto, aerospace, wind, mining, construction and other industrial gears.

Every tool is precision-made utilizing high speed steel, premium powder metal or carbide and the latest in coatings, to achieve superior cutting and long life. DTR uses top of the line equipment including Reischauer CNC grinders and Klingelberg CNC sharpeners and inspection equipment.

Learn more about our outstanding quality tools at www.dtrtool.com.
Call us at 847-375-8892 for your local sales representative or
Email alex@dtrtool.com for a quotation.



PERFECTION MOVES US
(formerly Dragon Precision Tools)
WWW.DTRTOOL.COM

DTR has sales territories available. Call for more information.

U.S. Office Location (Chicago) Email inquiries to: alex@dtrtool.com.
1865 Hicks Road, Suite A, Rolling Meadows, IL 60008
PHONE: 847-375-8892 Fax: 224-220-1311

Headquarters
85, Namdong-daero 370beon-gil, Namdong-gu, Incheon, Korea, 21635
PHONE: +82.32.814.1540
FAX: +82.32.814.5381

Big Kaiser Milling Chuck

DESIGNED TO ELIMINATE END MILL PULLOUT

Big Kaiser introduces the Mega Perfect Grip from Big Daishowa, a simple to handle, heavy-duty milling chuck for heat resistant super alloys (HRSA) that eliminates end mill pullout under heavy torque loads.

The Mega Perfect Grip, with fully concentric clamping, combines the accuracy and cutting performance of heavy-duty milling chucks with the security against pullout of solid side-lock tool holders.

The concept is simple and assembly is quick. To keep the system cost-effective, it is based around milling cutters with a standard Weldon flat (ASME B94.19-1997). No special grinding or threading of the milling cutter is required.

To assemble, insert the exclusive key grip into the Weldon flat of the end mill. Align the key grip with one of three key grip grooves inside the chuck body, and insert the cutting tool until it depresses a spring in the clamping bore. The spring functions to remove the gap between the key grip and the wall of the groove, and to provide a slight axial preload on the tool until final tightening is performed. Rotate the end mill approximately 20° until the grip stops securely against a stopping pin. This engagement prevents any slip under high torque. Finalize assembly by tightening the clamping nut until it contacts the positive stop of the chuck body.

The three key grip grooves in the chuck body also serve to provide channels for high-volume coolant to reach the cutter, which is required in milling HRSA to dissipate heat and to remove chips efficiently.

“Pullout can be a big headache when working with HRSA’s - costing time and money, and hitting manufacturers’ profitability,” says Jack Burley, vice president sales and engineering. “This innovative chuck solves the problem completely, combining innovation with ease-of-use and industry standards.”

The Mega Perfect Grip is available in Big-Plus BCV50 and HSK-A100 for Ø.750"-1.250", and HSK-A125 for Ø1.000" and 1.250". The product is in stock and ready for immediate delivery from Big Kaiser’s North American headquarters.

For more information:
Big Kaiser
Phone: (224) 770-2999
www.us.bigkaiser.com



PROTO

MANUFACTURING

a world of solutions

RESIDUAL STRESS & RETAINED AUSTENITE MEASUREMENT

Choose from one of our portable or laboratory systems, or utilize our ISO 17025 laboratories for accurate and efficient contract measurement services.

For more information contact us at info@protoxrd.com or 1-313-965-2900

www.protoxrd.com



LXRD
STANDARD



LXRD
WIDEBODY



LXRD
MODULAR MAPPING



iXRD
STANDARD



mXRD
ULTRA PORTABLE

The End of an Era — Joe Franklin's Valedictory

Jack McGuinn, Senior Editor

AGMA President Joe Franklin is stepping down after some 24 years on the job. He graciously took the time to answer some questions from *Gear Technology* Senior Editor Jack McGuinn regarding his tenure.

Gear Technology: Was the position one that you aspired to 24 years ago?

Joe Franklin: "I was excited to receive a call from Stewart Ward, in the summer of 1991, and pleased that after being vetted by the Executive Committee and Board, I was offered the job. Before AGMA, I worked twelve years for the National Machine Tool Builders Association, now known as AMT—The Association for Manufacturing Technology. AGMA's members are very similar, and several companies were members of each group."

How does AGMA look today compared to when you stepped in 24 years ago?

"In many ways, AGMA is quite similar to the organization of 1991; in a few others, I am pleased to say, we have been able to build on the foundation in place when I was hired. The overall mission and objectives of the association have not changed. In fact, you can look at our Articles of Incorporation and see that the reasons for existence have not changed in 100 years.

"Today, we have fewer staff positions and more specialization in each position. In 1991 most of the employees were generalists who learned to wear multiple hats. Our office space was in a converted Coke bottling plant with a leaky roof and dark offices. Today, we are in a relatively new space full of glass and light, designed to encourage interaction among the staff and visiting members.

"Membership has grown and become more diverse—more in the supply chain and more internationally. We



were financially stable then and, I would say today, our finances are such that the organization is guaranteed a future as long as the members want an AGMA.

"Our standards development activities, with the supporting array of technical committees, continue to be one of AGMA's most important programs. Today we are more heavily involved internationally with ISO and the several national gearing standards developing organizations.

"The education programs of 1991 were less frequent and tended to be produced to respond to an issue or problem of the time. Today we have eight established, advanced education courses, webinars and video delivery, as well as the FTM (Fall Technical Meeting) and short courses at Gear Expo.

"Gear Expo was just beginning in the early '90s, and today is a well-established, "must-attend" event for our industry. Of course, it is larger today in size and number of exhibitors and attendees.

"Most importantly, today as then, the Board, members and staff continue to look for ways to keep the organization fresh and in step with the industry."

What would you like to see the association accomplish going forward? Is there any unfinished business you just ran out of time to address adequately?

"The most important new item of business in front of AGMA today is the successful transition to its new president, Matt Croson. The Board and I will be working with him over the next several months to make sure

he has the support and information he needs to be successful. Matt is an experienced association executive who will bring new ideas and new enthusiasm to AGMA.

“AGMA does not have a “to do” list that no one has worked on. What we do have is a responsible Board of Directors and committed staff who are actively looking forward.

The Board recently changed how it approaches meetings; the Board now focuses more of each meeting on discussion of strategic issues and less on oversight and management. I think this is very wise and has promise of really driving the organization forward.

“Face it—it is a lot easier to come together for a couple days every four or five years and create THE Strategic Plan than it is to grapple with the strategic elements of building a relevant program to help educate the industry or to challenge yourself to add more value to all of our members, domestic and international. AGMA no longer has that “dusty binder” on the shelf; we do have a very impressive way for 22 representatives of the industry (our Board) to work with staff to continuously improve AGMA and to look beyond the daily activities for what’s next for AGMA and the industry.”

It seems there will always be a Fall Technical Meeting, but what about Gear Expo?

“The Fall Technical Meeting and Gear Expo trade show just keep getting better. I am pleased that with the excellent international conferences and congresses, the FTM is held in high regard everywhere. We always have a good array of international technologists and industry experts who offer papers for consideration. Remember, we always receive two or three times as many abstracts as we are able to accept for the conference. AGMA’s Technical Division Executive Committee (TDEC) evaluates the abstracts and selects the papers.

“Gear Expo is the industry networking event—an opportunity to see the most current technology for manufacturing gears and gearboxes. And this past show was a good place for OEMs to come to find sources for their power transmission needs.

“As long as the industry supports the events and tells the Board and staff, they will be supported by AGMA.”

How does AGMA stay relevant as an association in which highly skilled and talented people, as well as major corporations, will care to participate?

“I have long said the reason companies join and remain as members can be summarized in three words—access, credibility and voice.

“Let me explain.

“Access is what companies get when they join—networking with their peers, suppliers and customers. Networking is one way of expanding what we know about this business. It is an excellent way of vetting suppliers and processes—not so many of our members directly compete, so there are few barriers to talking.

“Credibility is what manufacturers get by publicly stating they are part of the gearing and mechanical power transmission industry. Your customers will know you have access to the best and most current technical information. One quite large member told me his company got credibility from AGMA because he could assure his customers that the way he was making their parts was the best because the technical committee had rejected the others.

“(The most important) voice is the voice of our members. At AGMA, the members set the agenda. If members do not support something, AGMA will

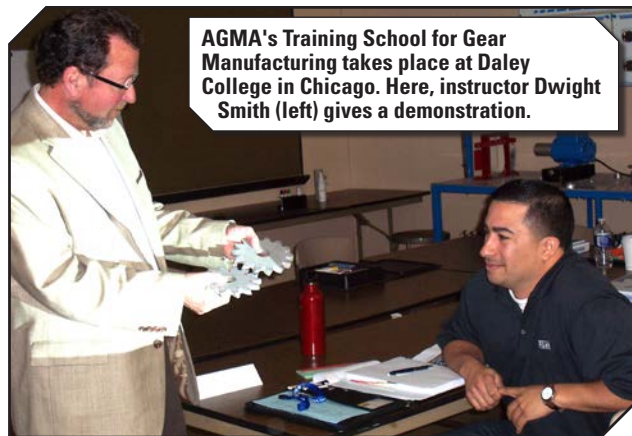

not waste time and money offering it. And when members have a need, the organization will work to provide it.

One example: in the early 1990s several smaller companies came to me with the idea that we start our own gear training program at a community college. They helped acquire some machines, find instructors, and together we got agreement from Daley College in Chicago to set up our Training School for Gear Manufacturing on their campus. Today we have taught innumerable individuals in our industry how to make gears. Interestingly, about a quarter of those in the school never make a gear. They are executives who came from another industry or PR staff or sales engineers. All need to understand gearing, but will not generally be called on to make gears.

“As long as AGMA continues to build opportunities for members to network, as long as members perceive value in membership, and as long as Board and staff continue to hear the voice of the customer, AGMA will attract the full range of companies and executives in the industry.”

Are you satisfied with AGMA’s accomplishments in gear education and job training?

“Developing a set of education programs for an industry is not a simple task. Because of the diversity of members and of education and training needs, it cannot be done quickly if you want to be effective. The nature of “crowd sourcing” means that you can get a very robust result—but it is never fast.

"Today, we have a group of proven courses and proven instructors; and we have a new Director of Education on staff and new instructors eager to begin working.

"I think AGMA is well positioned but, as always, is dependent on motivated members who are interested and capable of helping develop new courses."

You have presided over the association's greatest period of growth during your tenure. To what would you attribute that?

"I came to AGMA at a time much like today. Many of the employees and executives who came out of World War II were retiring and a younger group was coming in. Some were moving into their parent's companies; others were buying existing companies or starting from scratch. They all needed a way to know each other; all needed technical information and standards and all needed business tools like benchmarking studies.

"Additionally, with the greater attention on international technical standards, more international companies were interested in AGMA. We also increased our activity with international organizations like the Hannover Fair.

"The Board and our staff responded to the needs of the members; we tried to increase value of membership and

we met frequently with individual companies to discuss membership.

"In many regards, success builds on success and so it seems it did at AGMA. Membership grew, our revenue generating programs grew enough to allow improvements in benefits, and the cycle repeated.

"I always come back to the voice of the member. We were resolute in not offering what was not wanted, and in providing what was.

"As we had staff turnover, I moved to bring in specialists who knew trade shows, meeting management, adult education, and how membership organizations worked. I outsourced non-revenue-generating positions and used the savings to add staff that could generate revenue and grow the membership.

"Associations must not get out of sync with their members. I joke about the parade leader with the big hat and baton; every once in a while he needs to look back and make sure the band didn't turn without telling him.

"AGMA has been successful because the 22 Chairmen I have worked with,



AGMA's Training School for Gear Manufacturing offers hands-on learning for gear manufacturers.

and for, along with the 100 or so Board members since the early 1990s, loved this industry and worked cooperatively with the staff to meet the needs and desires of the members. The U.S. Department of Commerce classifies the industry as a mature or declining industry. Fortunately, they neglected to tell the thousands of individuals who work daily to improve the power transmission components and devices that almost no one in the general public knows is working for them."

What were some of your toughest times in the job?

"Industry downturns are inherently difficult. Many times, members need information and programs from the association in bad times more than they do in good, but many times do not have the necessary cash flow to support it. Bad times for the industry translate directly to bad times for AGMA. Still, we have a mission and purpose. I am pleased that most of the time we had the flexibility to accommodate what members needed."

What, if anything, would you have done differently—or acted sooner on—or later?

"With 20-20 hindsight, I probably would have done a number of things differently. The key is not to focus on the past but to learn from every experience and build a body of knowledge that helps you improve next time."



Since its beginnings as a table-top show in 1987, Gear Expo has grown to become the gear industry's largest event. Shown here is the Gear Expo Solutions Center.

How does the AGMA Foundation, which supports and strengthens education, training, and research for the gear industry, look as you prepare to turn over the reins?

“The Foundation Trustees and staff are refocusing the AGMA Foundation away from some of the purposes it had in the beginning. The most significant of the original objectives have been achieved and the programs are part of AGMA’s operating budget, not special projects.

“I am excited that the Trustees are increasingly moving to fund scholarships for college students who have an interest in mechanical engineering, and gearing in particular. The Foundation also funds the development of education courses.

“I have confidence that this will be the primary direction into the future. It makes more sense to give money directly to students than it does to fund university research programs that many times are a way of giving a student a fellowship. The scholarship puts 100% of the money toward getting the student educated; research can be considered on its own merits.

“Members have responded positively to the refocusing, and I hope it succeeds to help individuals like those the Foundation has funded over the past several years.”

What would you like your AGMA colleagues to consider as your legacy, if you will, to the association?

“I have tried to do my job with honesty and integrity. I have approached each member with respect, knowing that in most cases their job was rarely easy. And, if I or AGMA could offer a solution – that’s why we were there.” *(By the beginning of July, Matt Croson will be on the job full time and Franklin will drop his hours for the balance of the year. Croson will take over day-to day management of the association as Franklin works through 2016 with*

the primary responsibility of working with Croson on the transition. Both men will be visiting both individual companies and hosting smaller, regional group dinners, so Croson can meet the industry and get to know the players.) ⚙️



WWW.RAVEGEARS.COM





RAVE GEARS AND MACHINING



AS9100 QUALITY FROM START TO FINISH

Rave Gears promises to deliver the highest quality gears and machined parts, on-time, at a fair price.

Our Specialty: Spiral Bevel, Hypoid, Helical and Spur Gears

Current customers include Bell Helicopter, SpaceX, United Technologies, GE, Baker Hughes, Penske Racing.



Klingenberg P65 Gear Analyzer



Klingenberg G60 Gear Grinder



Mori Seki NT 5400

425 Stempel St. Seguin, TX USA 78155
(855) RAV GEAR | 855-728-4327 | 830-421-3295
sales@ravegears.com

Off-Highway Endures Soft Markets

The off-highway industry faces low demand and weak global economies, but is soldiering on.

Alex Cannella, News Editor

The off-highway industry is one under pressure from numerous market forces. The oil sector's decline, weakened global economies (particularly China) and local government policies outnumber and outweigh relieving forces such as the FAST Act, leaving the industry in a general downturn. The outlook has yet to become truly grim, but companies are beginning to scale back.

"It is a bit unprecedented to have the four end use equipment markets for mining, agriculture, construction and energy (oil and gas) all suffer slowdowns at the same time," Greg Moreland, global manager of market and product research at Oerlikon Fairfield, said.

The oil industry's turbulence is no secret — thanks to an almost overwhelming tide of oversupply, oil prices have nosedived to the lowest point they've been in decades, prompting many of the major oil companies to cut back on costs. BP has had multiple waves of layoffs to match their decreasing profits, the most recent cutting 4,000 jobs in January. Shell also announced they would cut 7,500 jobs last year, and both companies have announced more to come. Many smaller businesses that took advantage of the previously exploding fracking industry have outright shut down or gone bankrupt.

Worse, the price has yet to stabilize, much less begin to climb back to its previous state of \$100 a barrel. The energy sector still has a lot to sort out before they're in a position to invest in new equipment, and it will take even longer before anyone starts thinking about expanding operations or new businesses start to replace the ones that have gone under.

"In a longer term, I believe CAPEX will return to the oil and gas markets," Moreland said. "But there will be a period of adjustment where industry will need to adapt to the reality of lower oil and gas prices for the foreseeable future."

The real issue for companies like Oerlikon Fairfield is that other industries that could support them while the oil industry restructures itself are also facing their own struggles. The mining industry is running into the same problem oil is — the raw materials they're producing just aren't selling for what they used to, and that means companies don't have enough money to pay their own workers, much less invest in the latest drives for their equipment. Agriculture had, according to Moreland, reached the end of a buying cycle. Construction has seen hits to sales due to economic slowdown in countries such as China and Brazil. Even in the United States, things have been rocky in some sectors. Dodge Data and Analytics reported a 28 percent downturn last year in manufacturing plant construction, which they largely attributed to "pull-back by large petrochemical starts."

According to Moreland, it's not doom and gloom on literally every front. There are some portions of the construction market, primarily residential and commercial, that are faring a little better than their more industrial counterparts.

But the construction projects that are still going strong are only a small portion of the overall customer base manufacturers like Oerlikon Fairfield supply, and demand is declining. Like many companies that primarily supply off-highway products, simultaneous downturns in each of the major industries Oerlikon Fairfield supports, along with global economic woes, have made business more difficult.

"We have been dealing with the reduced business environment by leveraging supply chains and structuring the business to adapt to the conditions,"

Moreland said. "It is important, however, to protect key parts of the business that will be needed when conditions improve."

The Silver Lining

Even faced with uniformly soft markets, Oerlikon Fairfield has managed to score some hits. Most of their successes have come from individual products that have overcome low demand with specific features and advantages over their competition.

"Our successes tend to be product specific," Moreland said. "...We have recent releases with track drives and wheel drives which have applications in the construction equipment and agricultural equipment sectors. Although these are not strong and growing markets, because the new products offer some performance or feature advantages, they are being



adopted into new machine designs."

One such success has been the Champion series of hydrostatic drives designed for agricultural spray tractors. One of the series' primary selling points is its internal wet service brake, which

removes the need for the extra mounting hardware required to support external braking systems and protects the brakes from potential chemical corrosion, eliminating a safety and maintenance issue.

Individual hits such as the Champion series aren't the only thing Oerlikon Fairfield has going for it. While the off-highway industry may have been dealt a mostly bust hand, not every market force is working against them. Most notably, the Fix America's Surface Transportation Act (FAST Act) was passed in December.

For years, piecemeal and short-term bills have siphoned a trickle of federal funds into maintaining and developing America's infrastructure. The FAST Act, which is the first of its kind in over a decade, will provide \$305 billion over the next five years towards highway construction and maintenance, public transportation and more. Highway construction companies and other businesses maintaining the U.S. infrastructure system, metaphorically speaking, finally know where their next meal is coming from, and can safely plan longer and more intensive projects without worrying about funding being cut come the following year. And that means more sales for the off-highway industry, where some of that money is almost guaranteed to go. The FAST Act is a welcome and much needed boon for the industry.

But according to Moreland, it won't be enough to balance out the industry on its own, and there's other legislation that's as prohibitive as the FAST Act is helpful. Moreland believes that governments will have to go farther and reform corporate taxes, as well as institute more pro-growth legislation.

"Obviously, the U.S. government is not functioning in an ideal manner," Moreland said. "But, others are in the same situation. Policies enacted in Brazil have all but destroyed their AG equipment business. Starting with our government, and hopefully spilling around the world, useful pro-growth policies which support business and remove uncertainty can go a long way in stimulating global GDP."

Many of the industries off-highway supports are still trying to piece themselves back together and are a long way

from stabilizing — which means off-highway has a long way to go, as well, before the economic weather begins clearing. In the meantime, however, Moreland suggests that while weathering economic conditions, make sure you preserve foundational assets for better days in the future.

"I would suggest to follow those actions necessary to weather the current downturn, but always protecting those assets which form a company's DNA

and sustain growth in the up cycle," Moreland said. "Growth in these markets will return eventually. Although facing difficult conditions at this moment, the recent Bauma...was well attended, and this suggests that better days are ahead." 

For more information:

Oerlikon Fairfield
(765) 772-4000
www.oerlikon.com/fairfield



TURNING UP

THE HEAT

McINNES
ROLLED RINGS

Now offering complete heat treat capabilities for our seamless rolled ring forgings up to 144" diameter with the same speed and quality you've come to expect.

Turn up the heat with excellent customer service and the fastest delivery times in the industry.

Speed. Quality. McInnes Rolled Rings.

1.800.569.1420

sales@mcrings.com

www.McInnesRolledRings.com

Heat Treating Capabilities:

- Normalize
- Normalize & Temper
- Solution Treat & Age
- Anneal
- Solution Anneal
- Spheroidize Anneal
- Quench (Polymer, Water & Air)
- Temper
- Stress Relieve

Idler Gears

Email your question—along with your name, job title and company name (if you wish to remain anonymous, no problem) to: jmcguinn@geartechnology.com, or submit your question by visiting geartechnology.com.

QUESTION

What is the point of using two idler gears in a geartrain?

Expert response provided by Octave A. LaBath and Charles D. Schultz: Idler gears are used when a different direction of rotation is needed on the output gear of the geartrain. An idler gear can also be used when a larger center distance than the required ratio and gear size for the transmitted load is needed between the input gear and the output gear of the geartrain.

There are several reasons that two idler gears are used instead of one idler gear in a geartrain. Two idler gears may require less width on the geartrain with respect to the gear diameters. Two idlers may also have less total weight. Another reason to use two idler gears is when you need two more pads for accessory units that are to be driven by the geartrain.

I can recall an example gearbox where we had designed a gearbox with one idler gear to match the required center distance between the input shaft and the output shaft. When we presented our proposal, the potential customer rejected the design because it required that the output shaft rotate in the same direction as the input shaft. We were able to redesign the proposal geartrain sketch while we were still at the customer facility by using a copy machine, scissors, and white-out to show using two smaller idler gears in place of the larger single idler gear. While we were doing this the engineers back at the company were checking the rating on the two smaller idler gears for their strength rating.

The new design was approved, our company got the order, and we eventually built over 100 gearboxes with this design. Incidentally, most of the gearboxes are still operating on a U.S. Navy vessel. ⚙️

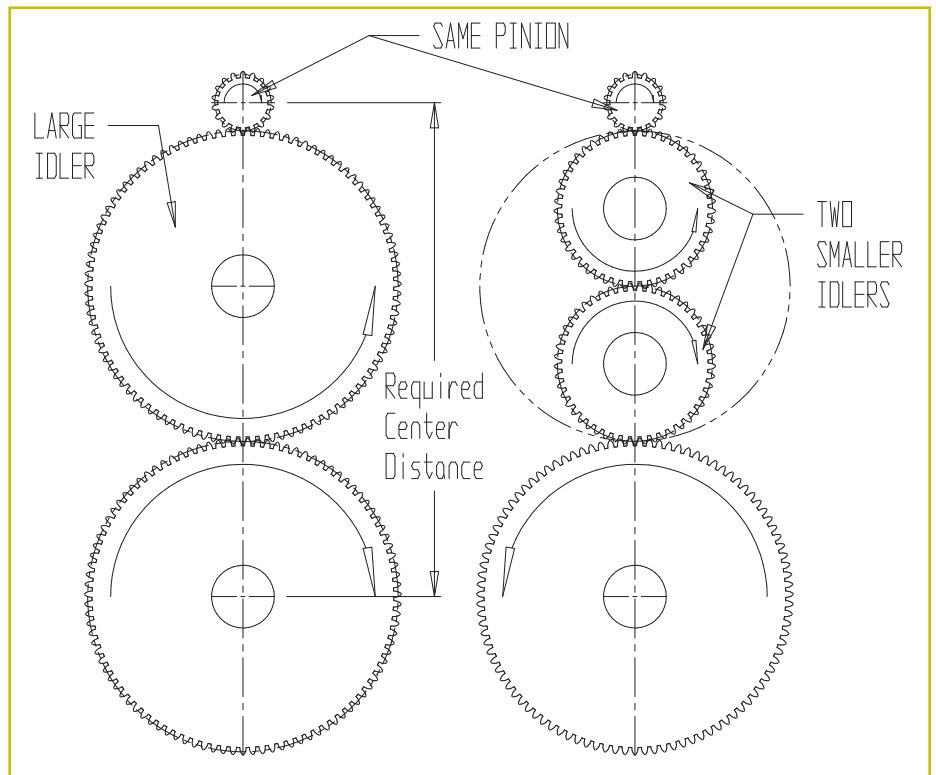

Figure 1 Single Idler

Figure 2 Two Idlers

Drawing provided by Charles D. Schultz.

For Related Articles Search

basics

at www.geartechnology.com

Octave LaBath (PE), a

lifelong gearing engineer and AGMA member, is also a Gear Technology Technical Editor. LaBath has served on a number of AGMA technical committees and is a recipient of the AGMA TDEC Award.



Chuck Schultz (PE) is a

Gear Technology Technical Editor and twice-weekly (Tues. and Thurs.) blogger (geartechnology.com), industry consultant (Beyta Gear Service) and longtime AGMA member and contributor.



Our Librarian Will Never Shush You

at the **GT LIBRARY**



That's because the GT LIBRARY is all online, and you can visit it anytime. Just go to *www.geartechnology.com* and use the search box for access to 32 years of technical content focused on gears.

- **Every issue since 1984**
- **More than 2,000 technical articles**
- **More than 6,000 archived news items**
- **Addendum, Publisher's Page, Back to Basics and more**

And the best news of all? You don't even need a library card. That's because the GT LIBRARY is open to everyone. Knowledge is free. All you have to do is go and get it.

www.geartechnology.com

KORO for Quality

Hob Sharpening Service

- ◆ Quick Turnaround 2 Day Service
- ◆ Spur Shaper Cutter Sharpening

◆ HSS & Carbide Hob with center hole and straight flutes



- ◆ Thin Film Coatings

◆ Length up to 7 inches

- ◆ Diameter up to 5 Inches



- ◆ Precise rake and spacing guaranteed to AGMA standards



◆ **RUSH SERVICE AVAILABLE**

Koro Sharpening Service
9530 85th Ave. North
Maple Grove, MN 55369

763-425-5247
info@korind.com

CUT BIG
WITH **CLC**

Need a gear machine that fits your needs?

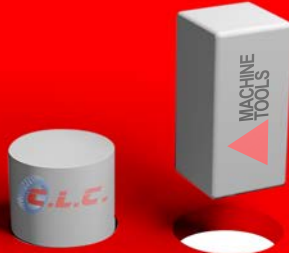

Learn more: CLCgears.com

KOEPFER
AMERICA, LLC



847-931-4121

koepferamerica.com

sales@koepferamerica.com

Dry Lube Coating

- WS₂
- MoS₂
- PTFE

MicroSurface

has unbeatable prices!

(408) 723-0700

info@ws2coating.com



Sharpening Services

- Hobs
- Milling Cutters
- Shaper Cutters
- Shaving Cutters
- Broaches



Service Centers

Hoffman Estates, IL
Phone: 847.649.1450
Fax: 847.649.0112

East Tawas, MI
Phone: 989.362.0414
Fax: 989.362.2720

Querétaro, Mexico
Phone: 52 442 217 34 45
Fax: 52 442 217 34 46



sales@star-su.com
www.star-su.com

QUALITY CUSTOM GEARING!

Documented
Quality Control Program

Inspection Lab
including Complete
Gear Tooth Diagnostics



Tooth Cutting, Grinding & Shaving Services Available

All Sizes & Configurations

- Reverse Engineering
- Design Analysis
- Complete Machine Shop Including CNC Machining



Circle Gear and Machine
Quality Custom Gearing Since 1951

1501 South 55th Ct. • Cicero, IL 60804
Ph: 708-652-1000 • Fax: 708-652-1100

Please email your inquiries to sales@circlegear.com • www.circlegear.com

SOMETIMES EVEN THE TOOTH FAIRY CAN'T FIND MISSING TEETH

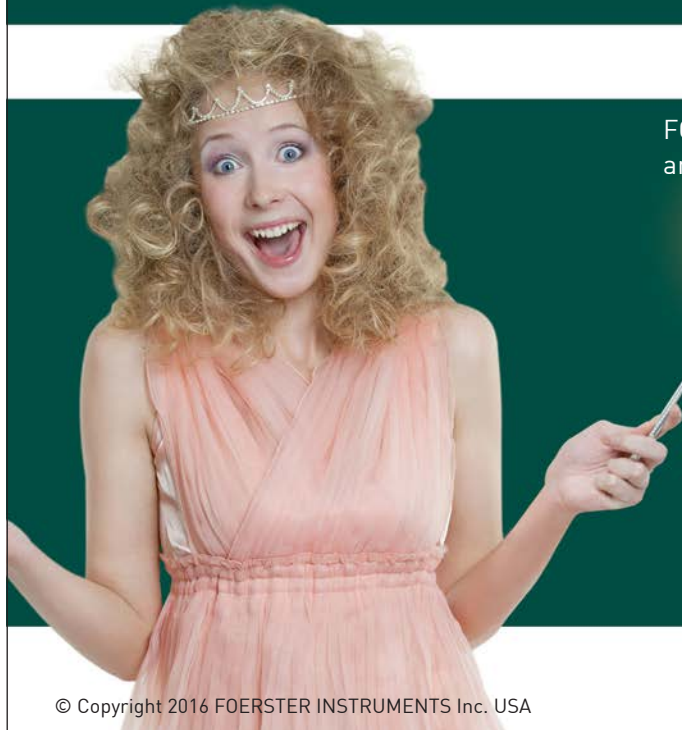

FOERSTER testing systems can verify material properties and heat-treat conditions; detect cracks, chipped or missing teeth in the most intricate of manufactured gears.

Utilizing eddy current technology, FOERSTER manufactures cutting edge Non-Destructive Testing (NDT) equipment designed to be incorporated into your current production line.

Contact a FOERSTER representative today to design your specific customized gear testing system.

© Copyright 2016 FOERSTER INSTRUMENTS Inc. USA

1-800-635-0613

foerstergroup.com



**INNOVATIVE
RACK & GEAR**

Gear rack specialists with state-of-the-art gear rack production capabilities including our most recent acquisition; Gleason-Saikuni HR-2000 CNC rack milling machine with hard-milling after heat treat capabilities up to 65 Rc hardness (producing impressive tooth finishes and accuracies comparable to rack grinding).

We will happily demonstrate samples produced for the most demanding of needs in aerospace, automation, off-highway equipment, defense, energy, machine tool, medical and others.

- Custom SPUR and HELICAL racks from a variety of materials
- Precision Quality up to AGMA 12
- Unique Tooth Configurations
- FINE and COARSE pitch (254 D.P. – 0.5 D.P.; 0.10 Module – 50 Module)
- Hard-cut up to 65 Rc and soft-cut up to 40 Rc
- 32" Face width and up to 288" lengths through resetting

630.766.2652

fax: 630.766.3245



www.GEARACKS.com
info@gearacks.com

365 Balm Court, Wood Dale, IL 60191

KAPP Grinding Tools 30 years of Solid Success

(303) 630-1792

tools-usa@kapp-niles.com



www.kapp-niles.com
www.kapp-usa.com



KAPP NILES

Nordex[®]
INCORPORATED

Over 32,000 standard components.

Buy online 24/7.

Nordex.com



presrite



PEOPLE AND TECHNOLOGY
MAKE THE DIFFERENCE

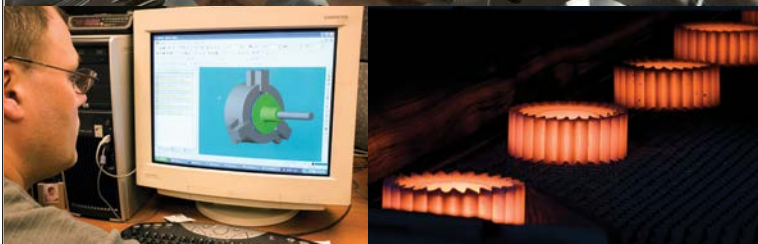

At Presrite, our experience, innovation and expertise ensure that you get the best net and near-net forgings. Our new Tech Center has state-of-the-art design, engineering technology and die-making capabilities.

- Dedicated state-of-the-art facility
- Presses up to 6,000 tons of capacity
- .008-.060 stock allowance on gear blanks
- ISO 9001:2008
- TS 16949:2009



www.presrite.com • 216-441-5990



DK SURFACE HARDENING
www.dksurfacehardening.com

Services

- Spin Flame Hardening
- Tooth-By-Tooth Flame Hardening
- Progressive Hardening
- Shot Blasting
- Vapor Blasting

708-233-9095

Fax: 708-233-9366

Managed by Dan King

contactus@dksurfacehardening.com

7424 W. 90th St.
Bridgeview, IL 60455

MIDWEST THERMAL - VAC

MTV has become a world leader in vacuum carburizing and vacuum heat treating for the Aerospace, Military, Motor Sports, and many other Commercial Industries, with multiple quenching capabilities to handle all commercial materials.

- Vacuum Carburizing
- Vacuum Carbo-nitride
- Vacuum Tool Steel & Stainless Processing
- Pulse-Plasma Ion-Nitride

23 Bar HPGQ or Oil Quench in Vacuum
Complete Certified Metallurgical Lab
NADCAP, ISO9000 & AS9100 Aerospace Approved

"Specialists in Vacuum Gear Processing"

Business Park of Kenosha
5727 95th Avenue
Kenosha, WI 53144

(262) 605-4848

Fax (262) 605-4806

Follow us at: **www.mtvac.com**

oelheld
innovative fluid technology

Innovative grinding fluids
to get your production into gear.

oelheld U.S., Inc.
1760 Britannia Drive # 1
Elgin, IL 60124
phone: +1-(847)-531-8501
fax: +1-(847)-531-8511
E-Mail: hutec-us@oelheld.com
www.oelheld.com

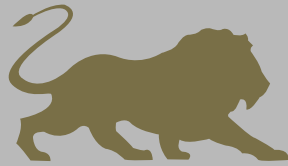

HobSource Inc

Custom gear cutting tools

**Performance
Dependability
Value**

866.HOB.TOOL
www.hobsource.com



bringing your

DESIGNS to **LIFE**

Gear & Spline Machining Services

- Spur, helical, crown, face, bevel
- Hard to machine alloys a specialty
- Full inspection CMM tooth charting

CNC hobbing, shaping, milling and turning with the latest state-of-the-art machine tools.

Zeiss, M&M, Gleason & Hofler CMM inspection.
Production lots, short runs, one-off or prototype.



Call us at (860) 738-2525

120 Industrial Park Rd - New Hartford CT
sales@perrytechnology.com
www.PerryGear.com



Do you Design Gears or Gear Drives?
Do you Buy Gears or Gear Drives?

Power Transmission Engineering
is for you.

Subscribe today at
www.powertransmission.com



Perfect Fit

Whether you need PM-HSS, G90 or carbide tools, we have the right solution to fit your application. All available with advanced PVD coatings for greater performance in all types of cutting conditions.

www.gleason.com/fit

Total Gear Solutions

Gleason

All-For-One, One-For-All

Advantages of Multi-Axis Machining in Gear Manufacturing

Matthew Jaster, Senior Editor

The “less is more” mantra is certainly a rallying cry in manufacturing. Technologies like multi-axis machining, 3D printing and automation are enabling companies to be more efficient, cost-conscious and flexible on the shop floor.

These will continue to be trending topics as the metalworking world comes together at IMTS 2016 (September 12-17, Chicago, IL).

“The increasing technological requirements of mechanical parts, combined with a shorter delivery time led us to establish more technology integration on our machines to help our customers to meet these increasing challenges,” said Dr.-Ing. Edmond Bassett, head of technology development at GILDEMEISTER Drehmaschinen GmbH, DMG MORI. Nitin Chaphalkar, product manager at DMG MORI confirms the increasing customer demand of multiple machining operations, such in five-axis Mill-Turn or Turn-Mill machines. “Especially in combination with exclusive technology cycles enabling the shop floor programmer to create complex geometries fast with high process reliability.”

“Today it is not possible to be focused on only one or two technologies. All equipment has to be combined in a suitable way,” said Dr. -Ing. Volker Sellmeier, head of technology development at Index. “Together with classic turning and milling operations, grinding to gear hobbing technologies are needed to machine a part completely in one operation.”

Mike Finn, senior application development engineer at Mazak, stressed the importance of multi-axis flexibility. “If you’re cutting a gear, it’s helpful when you have the ability to perform a variety of operations on a single machine. Turning, milling, power skiving and hobbing, for example, can add new elements to a manufacturer’s gear capabilities and provide additional shop floor

resources. This allows our customers to handle basically any kind of part that comes through the door.”

Gear Technology recently spoke with representatives from DMG MORI, Mazak, Index and Breton S.p.A. on the evolution of multi-axis equipment and what to expect from these machines moving forward.

DMG MORI Highlights Internal Gears, Inspection Technologies

The DMU 125 FD duoBLOCK 4th generation is the latest generation of DMU machines. The five-axis milling machine is capable of multiple machining operations including turning, milling and gear machining. “With this latest release, we’ve made some key improvements to machine accuracy and rigidity,” said Chaphalkar. “This machine offers cooling of the entire feed drive which increases the machine accuracy by 30 percent.” Machines in this DMU platform are offered in many different sizes which accept parts from 650 mm (25.59 in.) diameter to 3.4 m (133.85 in.)” he added.

Additionally, DMG MORI has increased the table stiffness which boosts machining performance. “Several DMG MORI exclusive technology cycles are available for use with the machines including *Machine Protection Control (MPC)* and *3D Quickset*,” Chaphalkar said. Today we offer 24 Technology Cycles exclusive to our customers on turning and milling machines. MPC offers protection when

machine vibration reaches a critical limit thanks to automatic fast shut-off, also in case of collisions. Additionally the cutting force can be monitored during drilling and tapping operations. *3D Quickset* is a quick calibration tool that provides accurate assessment of the kinematic center positioning. “Special technology cycles like these keep the machines performing at the highest accuracy level.

While the company will have plenty of innovations to present at IMTS 2016, Chaphalkar discussed two newly developed features that will immensely help gear manufacturers. “One is for machining of internal and external gears. We have been demonstrating the gearSKIVING technology cycle on our machines since last year and now DMG MORI offers a dialog guided programming interface for easy and safe shop floor programming. Customers will be able to

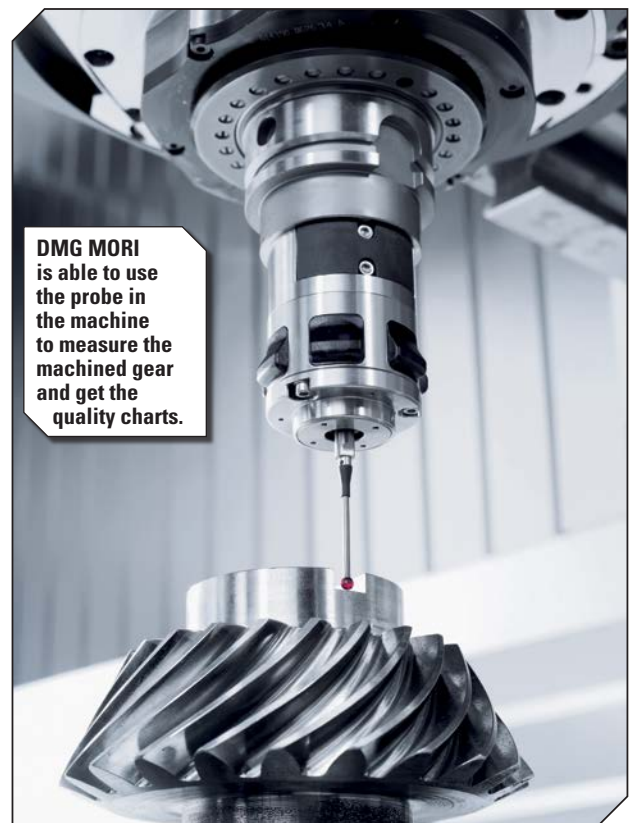

input both tool and gear data to produce a good part with gearSKIVING. This makes it easy for customers to program this complex process.”

This technology is being applied successfully on the DMU 125 FD duoBLOCK, turn-mill machines CTX-TC, and the NTX of DMG MORI.

“With gearSKIVING the customer can have the complete machining of the part on only one machine and reduce the conventional process chain significantly. The ability to implement such a complex process demonstrates the machines control capability as well as the rigidity of our machines. We have been able to machine a module 5 internal gear on a 300 mm (11.8 in.) part at quality of DIN 9 (AGMA 2000 – 8) with a cycle time of around 10 minutes,” Chaphalkar said. Smaller modules can be machined with a quality of DIN 7.

Another feature DMG MORI has improved upon is in-process gear inspection. “We are able to use the probe in the machine to measure the machined gear and get the quality charts. We have found good correlation between mea-

surement data from the machine and CMM. This allows the customer to be confident of the machined part before it is removed from the machine. We are able to measure many types of gears including spur, helical and spiral bevel gears. Additionally, this inspection capability gives DMG MORI customers the ability of finish machining heat treated gears. A module in the inspection software is capable of finding the center of the gear, finding the tooth and aligning the part by dividing the stock left for finishing,” he added.

Customers are also very interested in gearSKIVING technologies for machining ID gears. “I believe that is a very efficient process for making smaller module gears and customers would benefit by using this technology,” Chaphalkar said.

Another area the company continues to focus on is CELOS for all new DMG MORI machines. 16 apps help the operator to prepare, optimize and systematically carry out production jobs. CELOS apps provide solution for all applications-making them a solid basis for thoroughly digitized paperless production.

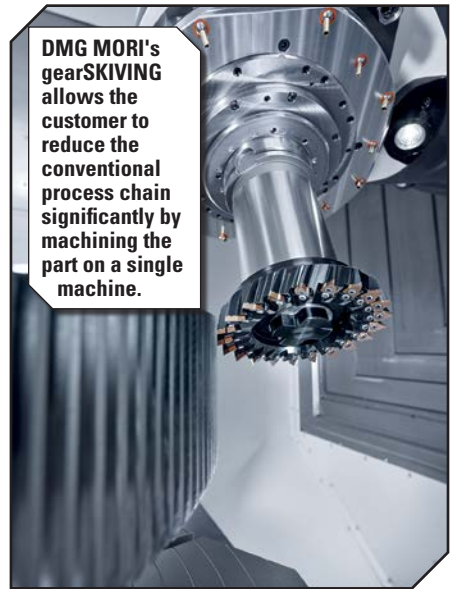

DMG MORI's gearSKIVING allows the customer to reduce the conventional process chain significantly by machining the part on a single machine.

“The CELOS environment gives the operator direct access to the machines including optimized planning, clear organization and live monitoring of all production processes. The machine also has about 60 sensors analyzing the processes within the machine tool and delivers detailed information on the current status of machine and the production processes,” Chaphalkar said. “CELOS



Penta Gear Metrology

Gear Metrology Systems

NEXT DIMENSION® Gear Measurement Systems



ND300



ND165

- Analytical Gear Inspection
 - DOB/DOP Gages
 - Double Flank Testers
 - Single Flank Testers
 - Gear Burnishing Machines
 - Gear Deburring Machines
 - Master Gears
 - Spline Gauges
 - REPOWERED Gear Inspection Machines
 - Metrology Services
- Contract Inspection

Windows7 64 Bit OS • Minimal Operator Training Required • Intuitive User Friendly Software

6161 Webster Street, Dayton, OH 45414
www.gearinspection.com

Email: sales@pentagear.com

Tel: 937-660-8182
fax: 937-660-4511

is a key element in a networked intelligent production facility with Industry 4.0. DMG MORI is an active partner in MTConnect standard and all of our machines are compatible for that data exchange format.”

Chaphalkar said that the Industrial Internet of Things (IIoT) and Industry 4.0 are the next developments that DMG MORI is focusing on. “Many machine tools are being underutilized right now and that operational efficiency can be improved,” he added.

Index Focuses on Complete Machining of Parts

The Index R200 and R300 are two machines gear manufacturers should take particular interest in, according to Sellmeier as well as the Index G220 which will be exhibited at IMTS. “Compared to the R-machines the G220 offers extended possibilities for the machining of shafts by using a tailstock function and/or a steady rest,” Sellmeier said. “Gear hobbing operations of cylindrical gears and spiral bevel gears are also possible on the G220 and quite often needed for the machining of shafts. In addition, the G220 offers the possibility to work with two tools simultaneously on one spindle. The gear hobbing operation of spiral bevel gears on the G220 will be shown at IMTS in Chicago.”

A distinctive feature of Index machine tools is the company’s high in-house production depth. “This means, that almost all of our spindles are built at Index,” Sellmeier added. “We use high-

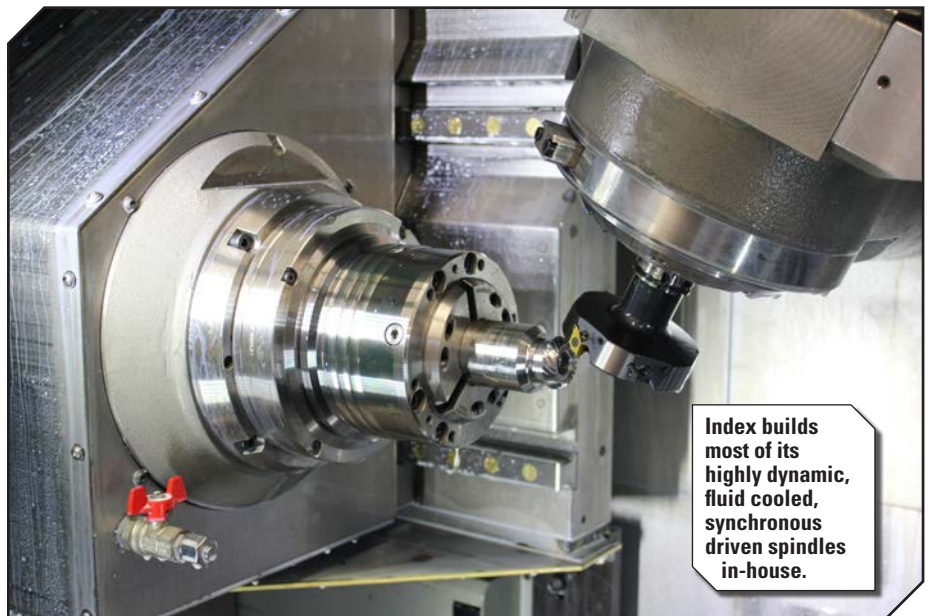

Index builds most of its highly dynamic, fluid cooled, synchronous driven spindles in-house.

ly dynamic, fluid cooled, synchronous-driven spindles in our machine tools. These spindles feature runouts of less than 1 μm . For most of our spindles it takes approximately only a second to reach the maximum spindle speed.”

Some of the key control advantages include the Siemens control (which is extended by many unique Index features) and offers a high, safe and convenient level of programming. “Together with our *Virtual Machine*, with the *Index VirtualPro* and/or *NXCAM*, our customers are able to program even high quality, complex parts in a short time. Regarding our bevel gear technology, which runs in continuous indexing mode, it is important to have an excellent “electronic axle” to guarantee the absolute synchronization free of play

between the milling spindle and the main spindle. One of our advantages is that our machine tools have no limitation of the maximum spindle speed due to this synchronization,” Sellmeier said.

The company is currently working on the single indexing method where it is necessary to have an extremely precise rotary positioning of the C-axis of the main spindle. “First tests with the single indexing method we did for a customer on a R200 resulted in a total pitch variation less than 3 μm . The high quality of our machine tools makes them very suitable for such challenging gearing operations,” he added.

Index has had several requests for the complete machining of parts from key customers for power tools and gearboxes as well as aerospace customers. “In 2013, we showcased the Index face hobbing technology (continuous indexing method) for the complete machining of spiral bevel gears at the EMO in Hannover for the first time,” Sellmeier said. “Since then we had a lot of requests from customers not only for face hobbing but also for face milling (single indexing method) of spiral bevel gears including cutter tilt and universal motions. At the moment, we are conducting some tests in this direction with our customers.”

Another technology that Index customers are asking for is power skiving. “Many parts could not be machined completely due to some external or internal gear teeth which had to be cut on special shaping machines. Power skiving offers the possibility to cut such



The high quality of Index's R200 makes it suitable for several challenging gear operations.

teeth on the turn-mill center as well. This means less investment, less floor space, faster cycle times and better quality,” Sellmeier said.

Additionally, software development is a key trend facing machine tool providers. “We have to provide all the software which is needed to control not only the machine but also the whole manufacturing process,” Sellmeier said. “Our answer is *Xpanel* which allows the integration of an Index machine in the local network of a customer just like a personal computer. With this solution it is possible for the machine or for the worker to get access to all manufacturing information which is available in the customer’s network.”

While Index is most known for its turning machines, they are focused on the complete machining of parts. “In the future, we plan to extend our capabilities in milling; our new turn-mill center G220 a larger milling spindle with HSK-63 will be released soon. Right now we are also working on the successor of the G200 the G200.2. Other important technologies that we implement on Index machines are grinding and gearing

operations. After the continuous indexing method for spiral bevel gears we plan to release the technology package for the single indexing method including cutter tilt and universal motions towards the end of this year,” Sellmeier said.

Regarding automation, Index has developed a new bar loader, the MBL65, which will be shown at the AMB in Stuttgart this year. “Machine intelligence is a very important topic for us. The cross-linking

of machine tools and production processes will be a key feature for production in the future,” Sellmeier added.

Mazak Combines Five-Axis Machining with VTC Capabilities

The Mazak Integrex Vertical I and E Series are able to perform milling, turning, boring and drilling operations in a single setup. Manufacturers can reduce the inaccuracies that occur when moving heavy parts across multiple workstations, eliminate work-in-process inventory and boost overall throughput utilizing these machine tools. “These



Mazak's Integrex Vertical I and E Series are able to perform a variety of tasks for a broad range of application requirements.

EXCEL-LENCE AT WORK

EXCEL CNC RETROFITS – SMART MOVE!

Your best investment. We're now restoring outdated gear machines to like-new condition – and saving our customers thousands of dollars vs. a new machine purchase. With our exceptional engineering and in-house machining and grinding capabilities, EXCEL is the 'perfect fit' for CNC retrofits.

Circa '80s shaper and hobber recently retrofit with powerful new FANUC CNC for a major aerospace manufacturer.



Ready to Excel? Contact:

EXCEL
CNC RETROFIT LLC
DRIVEN BY EXCEL-LENCE

A DIVISION OF
EXCEL GEAR

815.270.1004 / www.excelgear.com

machines meet the changing needs of our gear customers,” Finn said. “They offer two-axis turning, five-axis milling, boring, drilling and other operations via a powerful turning spindle, high-speed milling spindle and a wide array of tool storage options.”

This advanced multitasking functionality allows the machines to easily handle large, highly complex components from aluminum, steel and high-temperature alloy materials. Finn said that the machine’s integral motor C-axes are necessary for speed and accuracy improvements. “There is no gearbox for the milling which allows the table to rotate faster.”

The machine’s direct-drive, large table eliminates backlash for smoother rotation in heavy-duty cutting operations. High-speed and high-torque milling spindle specifications meet a broad range of application requirements in industries such as aerospace, heavy construction and energy. In addition, it comes with a two-pallet changer that provides unattended operations and off-cycle part setup. “This automation capability allows operators to load, unload and inspect parts on one pallet while the machine works on the other undisturbed.”

Mazak’s Mazatrol SmoothX CNC control technology, delivers faster processing of fine-increment programs and higher rotary axis rpms. Faster processing improves fine-increment five-axis tool-path flow used to cut spiral bevel gears and the higher rotary axis rpm allow for optimum cutting conditions for power skiving. “Power skiving has been around for a long time in the gear industry, but it’s still a relatively new concept in the general metalworking world,” Finn said.

There is little room for error in power skiving as both the workpiece and cutter masses spin, the slightest miscalculation in terms of synchronization will immediately cause chatter that will continue until the cutter is completely removed from the cut and adjustments are made. There are also speed limitations. For example, how fast can the C-axis spin while maintaining proper synchronization with the milling spindle? Dedicated skiving machines typically offer higher synchronized-rpm capabilities. Mazak’s SmoothX CNC control technology continues to boost the speeds/rpms at which its multitasking machines maintain skiv-

ing synchronization, according to Finn.

Mazak’s SmoothX CNC control technology functions in high-speed machining, cutter path adjustments, position-controlled hobbing and variable acceleration control. A larger display (19-in.) and intuitive touch screen enables faster programming and user-friendly navigation. Complex gear cutting requires lots of data points. “This is where the SmoothX control really shines,” he added.

In addition to control technology, Mazak has made some general machine design upgrades. The front of the machine, for example, offers a wider work envelope so operators can get in and out of the machine easier. The tool magazine is located next to the operating area for simplified and accessible tool setup.

At IMTS 2016, Mazak plans to roll out a variety of machine tool apps and remote services that will enhance production in the future. “We can’t say much at the moment, but we’re excited about the new machine tool features and capabilities that we’ll be rolling out in Chicago this fall,” Finn said.

Breton Offers One-Piece Flow Gear Production

Breton offers two specific machine tools relevant to gear manufacturing, the Xceeder series and the Ultrix series. The Ultrix series are multitask five-axis machining centers with a vertical spindle, rotary tilting table, mobile cross-beam, gantry structure and turning bar

for vertical turning independent from the electro-spindle. This range includes various models: Ultrix 800 RT, Ultrix 1000 RT HD and the new for 2016 Ultrix EVO 1200. The table rotates around the C axis and reaches speeds of 100 rpm for milling operations and up to 500 rpm for turning operations. The A tilting axis can reach speeds of 50 rpm. The linear axes travel at speeds of 60 m/min. Ultrix multitask centers offer a number of different machining operations in one including turning, milling, boring and grinding. Downtimes for workpiece repositioning are eliminated. The vertical design of these Breton machining centers is a suitable solution for machining workpieces with diameters greater than the height of the piece.

Xceeder is a range (Xceeder 900 RT, Xceeder 1200 RT HD and the new Xceeder EVO 1400) of high-speed machining centers designed and developed by Breton S.p.A to satisfy demanding machining requirements across various industrial applications such as the aerospace industry, precision engineering and die manufacturing. The gantry structure and rotary tilting worktable with direct drive are significant and innovative features ensuring a high production output and performance enclosed in a compact design. The machine’s steel structure benefits from improved structural rigidity compared to a conventional metal structure thanks to an engineered polymer filler designed to absorb up to 10 times more vibrations



Breton's five-axis machining centers offer flexibility in manufacturing different gear types and sizes.

offering high machining performance when milling complex workpieces with five axes. The thermal symmetry of the machine structure and thermal stabilizing system ensure maximum machining precision when operational and production conditions vary.

“Breton offers a full gear manufacturing software suite with the ability to work both in five-axis with cylindrical end mills and with dedicated face mill tools for small bevel gears,” said Sergio Prior, marketing manager at Breton S.p.A.

The unique characteristics of the Xceeder include four different electrospindles, all with an integral temperature control circuit making it possible to machine special alloys such as titanium and Inconel with the maximum chip removal capacity. All versions of the Xceeder machine line can be equipped with a tool magazine with up to 200 positions, automatic pallet changer and a full range of options that are capable of meeting the most complex requirements.

“The Ultrix EVO 1200 and the Xceeder EVO 1400 are trunnion type mono-block machines that offer a rotating and tilting table where the turn-

ing bar is independent from the electro-spindle,” Prior said. “Multi-touch Breton Gear CAM suite allows operators to modify cutting strategies and tools independently, directly on the machine control, facilitating one-piece flow gear production.”

The flexibility in manufacturing different gear types and sizes is one of the key benefits of the latest Breton machine tool technology. “The ability to make topological modifications to the gear tooth geometry to optimize the contact pattern between two meshing teeth, increase tooth load capabilities and decrease noise are additional benefits,” Prior added.

One customer that is currently utilizing these technologies is SEW Eurodrive. The company is using five-axis milling on case-hardened crown bevel gears (20-in. diameter, AGMA 12). These gears are perfectly meshing with pinions produced on a standard gear cutting machine, according to Prior. “The company is seeing reduced lead times from design to manufacture using only commercial milling tools (round-end mills). This includes any type of spiral bevel,

herringbone, spur, helical, face or special geometry gears up to 40-in.,” Prior said.

The trend today is to optimize the stiffness to mass ratio of the machine structure in order to provide high-speed machining. “Improving dynamic performance by reducing chatter and other vibration phenomenon is essential,” Prior said. “We’re moving more and more towards hybrid machining today by consolidating several machine operations into one machine (turning, milling, threading, etc.).” 

For more information:

Breton USA
Phone: (941) 360-2700
www.bretonusa.com

DMG MORI
Phone: (847) 593-5400
us.dmgmori.com

Index Corporation
Phone: (317) 770-6300
www.indextraub.com

Mazak Corporation
Phone: (800) 331-9151
www.mazak.com

For Related Articles Search

multi-axis 

at www.geartechnology.com



HANS-JÜRGEN GEIGER

Maschinen-Vertrieb GmbH

Metzingen/Stuttgart



High quality used machine tools from Germany since 1968.

Please visit our showrooms:
7000 sqm display area with more than 600 machines in best condition.

HANS-JÜRGEN GEIGER
Maschinen-Vertrieb GmbH
James-Watt-Straße 12
D-72555 Metzingen (Germany)
Phone +49 (0) 7123 / 18040
Fax +49 (0) 7123 / 18384
E-Mail: geiger@geiger-germany.com

- MIKRON
- DMG | DISKUS
- TBT | HELLER
- ELB | NAGEL
- SCHAUDT
- KEHREN
- KARSTENS
- MIKROSA
- INDEX | ZEISS
- BOEHRINGER
- GILDEMEISTER
- SCHÜTTE
- AGIE | SCHULER

Gear cutting machines:

- LORENZ | HURTH
- PFAUTER | KAPP
- KOEPFER | NILES
- LIEBHERR
- REISHAUER
- LINDNER
- KLINGELNBERG
- GLEASON
- WMW



b-werk.de

www.geiger-germany.com

Noise Reduction in an EV Hub Drive Using a Full Test and Simulation Methodology

Dr. Owen J. Harris, Dr. Paul P. Langlois and G.A. Cooper

With the ongoing push towards electric vehicles (EVs), there is likely to be increasing focus on the noise impact of the gearing required for the transmission of power from the (high-speed) electric motor to the road. Understanding automotive noise, vibration and harshness (NVH) and methodologies for total in-vehicle noise presupposes relatively large, internal combustion (IC) contributions, compared to gear noise. Further, it may be advantageous to run the electric motors at significantly higher rotational speed than conventional automotive IC engines, sending geartrains into yet higher speed ranges. Thus the move to EV or hybrid electric vehicles (HEVs) places greater or different demands on geartrain noise. This work combines both a traditional NVH approach (in-vehicle and rig noise, waterfall plots, Campbell diagrams and Fourier analysis)—with highly detailed transmission error measurement and simulation of the complete drivetrain—to fully understand noise sources within an EV hub drive. A detailed methodology is presented, combining both a full series of tests and advanced simulation to troubleshoot and optimize an EV hub drive for noise reduction.

Introduction

A combination of regulations and consumer expectations drives the demand for reduced noise in all drivetrain components. Further demand is driven by the growing trend towards electric vehicles (EVs) and hybrid electric vehicles (HEVs), where noise from internal combustion engines is intermittent or no longer present, and the contribution of transmission noise to overall vehicle noise becomes dominant—making it more difficult to achieve customer satisfaction.

In this paper we share our experience of how NVH issues can be addressed at both design and development stages with a combination of detailed measurement and computer-aided engineering (CAE) simulations. The methodologies given for CAE simulation should be used during the design stages to try to minimize the risk of any NVH issues prior to development. However, NVH issues in fact often first arise during prototyping and in-vehicle installation. Time scales for solutions are then short, and commercial pressures high. We believe that the rapid NVH troubleshooting required is best supported by a combination of comprehensive tools, methodologies and expertise.

An Electric Vehicle Hub Drive

The gear drive to be considered is the hub drive for a recently developed, fully electric bus. The vehicle has been widely distributed worldwide as a demonstrator vehicle and represents a good, potential solution to contribute to “green” urban transport. But the vehicle is perceived by some potential customers to exhibit high noise, and so a program was undertaken to assess, understand and reduce it.

Figure 1 shows the details of the drive, of which there are two per vehicle—driving the left and right rear wheels. Key points to note include:

- The hub unit is an integrated unit, which is comprised of the electric motor, geartrain and wheel hub bearings
- The drivetrain is a reduction ratio of approximately 17
- The ratio is achieved using three gear stages
- Progressing from the electric motor, the first and second gear

stages are parallel helical gearsets; the third is a helical planetary set

- The typical operating range is 0–7,000 rpm for the electric motor or drivetrain input

Noise and Transmission Error Measurements

A first step in investigating any perceived noise issue is to take detailed, objective measurements. To do this the authors developed their own in-house, detailed measurement system—MEASA (Ref. 1). The system combines all of the necessary hardware, data capture, and data analysis software in one integrated solution. This approach allows for more detailed work than potentially possible with commercial, off-the-shelf solutions (e.g., providing detailed transmission error measurements). It has also enabled the authors to integrate the test and CAE simulation results described in this paper in greater detail.

Figure 2 shows the details of the measurements system; it

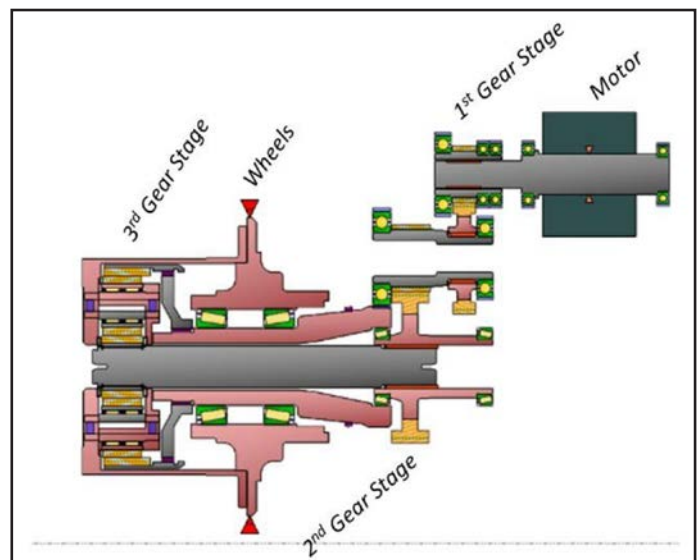

Figure 1 Cross-section showing geartrain in electric bus hub drive.

combines both traditional noise and accelerometer measurements with loaded transmission error (TE) measurements. Transmission error will be discussed in more detail below; we believe both measurement and simulation of TE can be critical in solving gear-related noise.

Noise and acceleration testing; results. The EV hub drive has been tested — in both the vehicle and on an isolated test rig; the former clearly provides the best direct indication of the unit’s performance with respect to customer experience. The test rig is useful during troubleshooting, as the test conditions and environment can be much more carefully controlled than with in-vehicle testing on a test track.

It is important to note that the full test conditions do need to be more comprehensive for an electric vehicle drive with power regeneration. They are:

- Forward drive or acceleration under the full range of throttle positions, which will engage the “drive” flanks of the gears
- Forward coast or de-acceleration under the full range of breaking and power regeneration, which will engage the “coast” flanks of the gears
- Similar for reverse — although this is often considered to be much less critical — as its percentage of the drive cycle is much less than forward

Figure 3 shows the classic “waterfall-type” plots during in-vehicle testing. Note that the noise was recorded at a range of microphone positions throughout the vehicle, with the most critical found to be in a passenger seat position directly above the wheel hubs. The waterfall plots show:

- Very clear order lines are present; these are indications of quite distinct frequencies that are linearly increasing with speed. Such noise content is often described as “whine” and is a tonal noise that can stand out in subjective assessment.
- There is less evidence of more broadband noise, which is often associated with a rattling-type motion. For example, in drivetrains with an internal combustion (IC) engine, torque oscillations from the engine can generate a rattling in the gears. This EV application shows much more of a whine-type noise signature.

The next step in the troubleshooting process is to analyze the orders to identify which components can be associated with each order line.



Figure 2 Authors’ in-house hardware solution for noise/vibration testing and transmission error testing, showing portable hardware used within project.

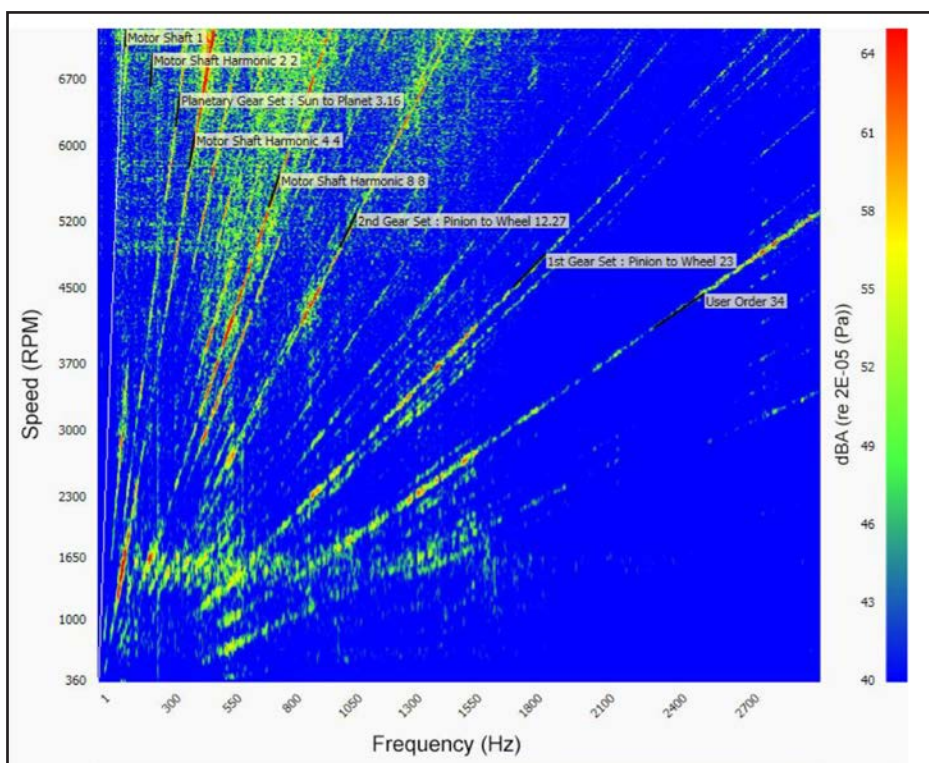

Figure 3 Waterfall plot showing typical noise measurements from in-vehicle testing of electric bus; this is drive condition with component orders superimposed.

Table 1 lists the orders corresponding to the gear stages, shafts, and bearings. These are relatively simple to calculate by hand (for example, the first-stage pinion has 23 teeth, so its order with respect to the input shaft is 23), but will become increasingly complex as transmission complexity and power flows increase as, for example, with a hybrid electric vehicle. As described in the CAE section, the authors use the commercial MASTA software solution to automatically generate all these orders and transfer them to the MEASA data analysis software (Ref. 1).

The results in Table 1 show how the component orders decrease as the speed reduces through the drivetrain. Also shown are the corresponding frequencies at the maximum motor/input operating speed of 7,000 rpm. It can be seen that the third gear stage frequencies are relatively low-frequency and may not be as objectionable to a passenger, compared to the higher-frequency first and second stages.

The results of Table 1 can now be superimposed on the waterfall plot to qualitatively identify which components are contributing noise; this is given in Figure 3 and shows that:

- All three gear stages can be clearly seen in the noise waterfall plots; further harmonics of the fundamental orders can be seen.
- In addition, some very clear harmonics of the once-per-revolution order of the input shaft are present — in particular, orders 4–9; these have been identified as orders associated with the electric motor and are beyond the scope of this paper and the geared drivetrain optimization.
- Little evidence of explicit bearing passing orders is seen.
- An unexplained order 34 is present; a potential source is a “ghost” gear frequency — i.e., an artefact of the gear manufacturing process. This was confirmed during the project and this order was eliminated with optimized gears.

In order to quantify the contributions of these identified orders, order slices — or order plots tracking the contribution versus speed — are plotted in Figure 4; total noise is also given

Table 1 Component orders and frequencies in EV hub drive		
	Order (with harmonics)	Frequency, Hz (at input speed of 7000 rpm)
First gear stage, tooth-passing	23 (46, 69)	2683 Hz
Second gear stage, tooth-passing	12.27 (24.54, 36.81)	1432 Hz
Third gear stage, tooth-passing	3.16 (6.33, 9.49)	369 Hz
Input and motor shaft, once-per-rev	1	117 Hz
Intermediate shaft 1, once-per-rev	0.51	60 Hz
Intermediate shaft 2, once-per-rev	0.22	26 Hz
Output shaft, once-per-rev	0.056	7 Hz
Motor shaft rolling bearings	6.07, 5.57	708 Hz, 650 Hz
Input shaft rolling bearings	4.08, 6.06, 6.06	476 Hz, 707 Hz, 707 Hz
Intermediate shaft 1 rolling bearings	2.33, 2.08	272 Hz, 243 Hz
Intermediate shaft 2 rolling bearings	2.95, 2.95	344 Hz, 344 Hz
Output shaft (hub) rolling bearings	0.77	90 Hz

for comparison. These order plots reveal a clear indication of how much each gear mesh contributes to the total noise and identify any speed regions where system resonances excited by a component occur.

A critical metric often considered is the minimum difference between the gear order noise and the total noise across the full speed range. For an IC engine application, the authors believe that targeting a minimum difference of 12 dBA in the in-vehicle noise will ensure that no gear whine is detected by the passenger. For EV and HEV applications the gear noise contribution can be greater, as a percentage of total noise due to an intermittent or non-existing IC contribution. In this project an absolute reduction in gear order noise was targeted.

Introduction to Theoretical Transmission Error and Gear Whine.

As seen in the previous section, noise and vibration testing can be used to identify clear tonal noise corresponding to once-per-tooth passing orders of gears; this is often referred to as gear whine (Ref. 2).

Gear whine is an NVH phenomenon, most commonly sourced from transmission error (TE) at engaged gear meshes. Theoretically, an infinitely stiff gearset with perfect involute form and no misalignment would transfer angular veloc-

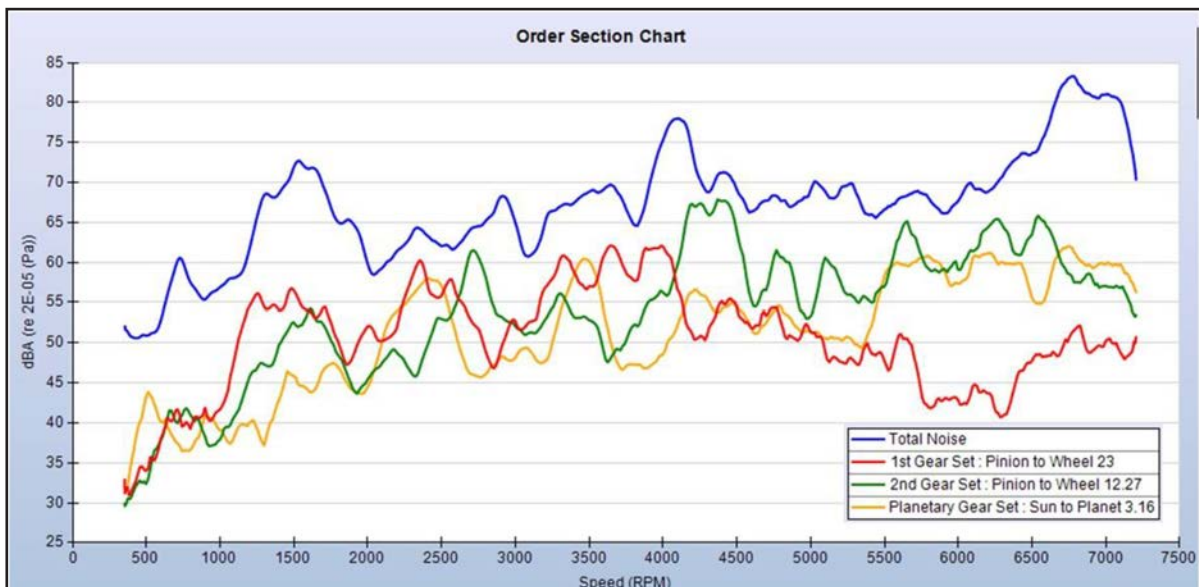

Figure 4 Order cuts through waterfall plot, showing typical noise measurements from in-vehicle testing of electric bus; this is the drive condition.

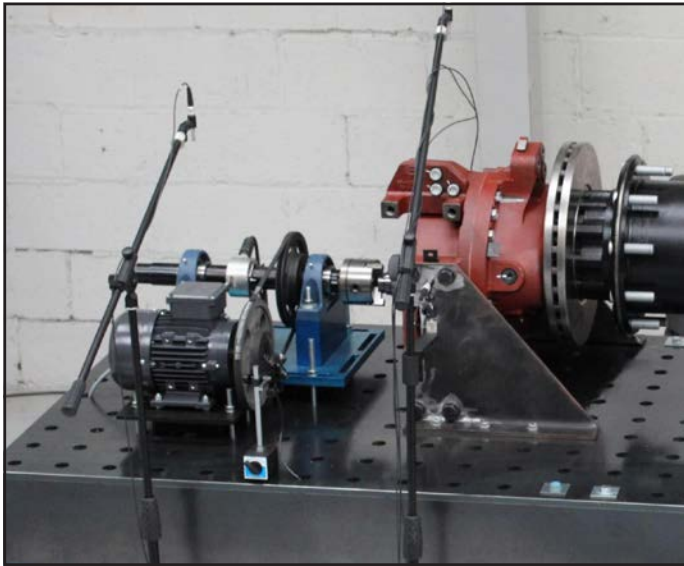

Figure 5 Test rig for making transmission error, noise and accelerometer measurements while running with light load.

ity exactly in accordance with the designed ratio. However, in reality no gear is perfect and, for example, tooth bending and misalignment caused by deflections of the system contribute to real gears not performing to this ideal. TE is the difference between the angular position that the output shaft of a drive would occupy if the drive were perfect — and the actual position of the output. Note that other authors may use the actual position — minus the expected position. In this paper we use expected minus actual. Under this convention TE values are usually positive, as the actual position is typically less than the expected, due to take-up of backlash and compression of the system under load. Other potential, but less common, sources of gear whine whose fundamental frequency is also at once-per-tooth, include axial shuttling forces where the axial location of the resultant force varies through the mesh cycle, resulting in a varying moment on the gears, and friction forces from the relative sliding at the gear mesh (Ref. 3).

Transmission error can be considered a periodic, relative displacement at the gear mesh in the line of action, caused by less-than-ideal meshing conditions. TE can dynamically excite the transmission via a path from the gear mesh, through the shafts and bearings, and on into the transmission housing. Gear whine is the resulting tonal noise radiated from the housing or transmitted from the housing and radiated elsewhere. Gear whine should therefore be considered not just a gear problem — it is a systemic problem — with the gears as the excitors of the system.

Transmission error: testing and results. For a multi-mesh drivetrain such as this we will refer to the drivetrain TE (with respect

to the drivetrain input and output) as the “system TE.” The concept of TE is often associated with single gearsets. The system TE will be the summation of the three gearsets’ TEs, noting that TEs are periodic and their relative phases are important.

Figure 5 shows the experimental set-up used to measure the system TE of the EV hub. As discussed above, this measurement should fully capture the TE as the source of noise. In this set-up we have measured the full drivetrain, as assembled; this ensures that we capture all the potential sources of the TE. For example, build quality misaligning the gears and gear manufacture quality, as well as the fundamental gear design. In addition, by moving the position of the input and output encoders it was possible to measure sub-parts of the drivetrain (e.g., just the 2nd stage).

In order to derive the individual gear mesh TEs, it is necessary to use Fourier analysis to decompose the total system TE signal into those components corresponding to each mesh. This will use the different gear orders (with respect to the input) given in Table 1. Figure 6 shows this process. Key points to note include:

- The total TE has quite large periodic variations — at once-per-revolution of input, intermediate and output shafts. These can be attributed to run-out of these shafts or the encoders, which is likely to be present to some degree in all drivetrains. These oscillations, from a noise perspective, will be low-frequency and not relevant to gear whine.
- Where the data is examined on shorter (higher frequency) timescales, the once-per-tooth oscillations corresponding to the gear meshes are seen.
- The Fourier analysis clearly shows how total TE is composed

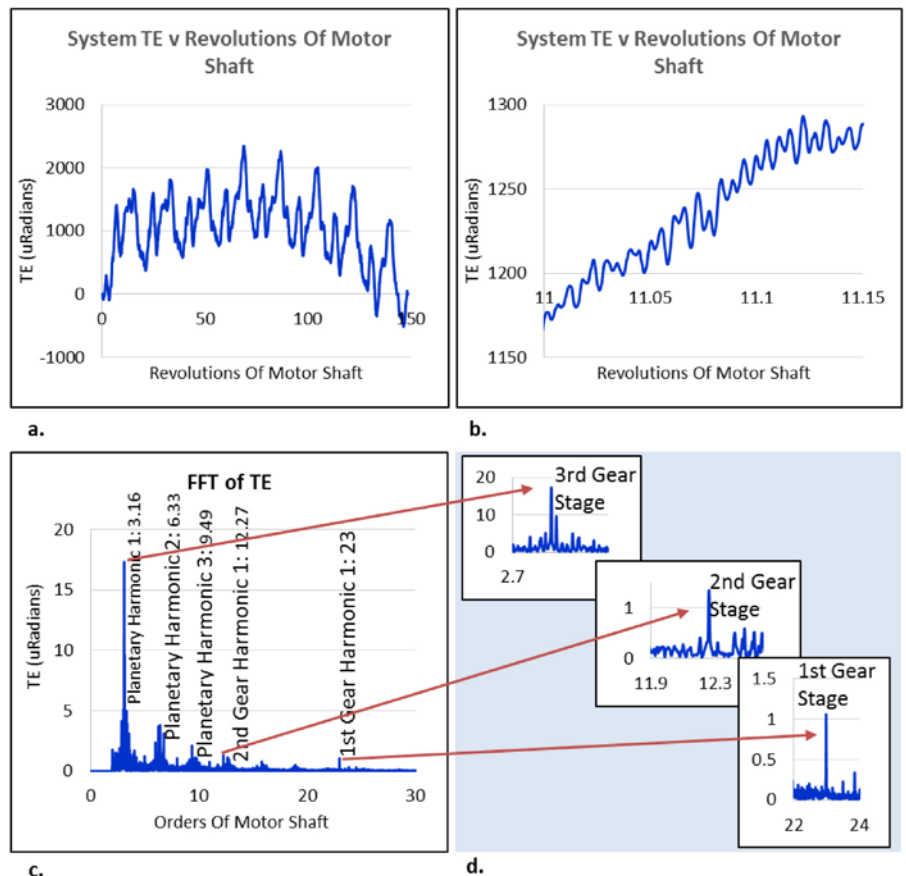

Figure 6 Transmission error testing results showing data analyses required to extract individual gear mesh TEs. From top: graph (a) full raw system TE; (b) zoom to smaller timescale showing oscillations due to tooth passing; (c) and (d) show Fourier transformation.

of the TE due to the gear meshes. The meshes of the three gearsets and their corresponding harmonics can be clearly identified.

- Some sideband structures can be seen. For the second stage the sidebands are predominately at one-order intervals with respect to its pinion shaft, suggesting pitch error or other manufacturing errors of the second stage pinion gear. The sidebands structure of the third stage may not necessarily be due to manufacturing error, as sideband structures are a known artefact of planetary gear sets (Ref. 4).

For cylindrical gears, TE values are typically given as a linear value derived from the angular error across a mesh multiplied by the base radius of the reference gear. Table 2 lists these for the first and second stages. It is necessary, when extracting the TE of individual meshes, to include the speed ratios through the drivetrain. The system angular TE is a measurement of the combined, relative angular position error due to all meshes in the drivetrain; it is the product of not only each individual gear mesh TE, but also the speed ratio between each mesh and the reference point of the measurement (output). Therefore, in Figure 7/part c, the contribution of each mesh will appear greater or smaller than its equivalent linear mesh TE, depending upon whether the base radius of the gear used to calculate linear TE is rotating more slowly or more quickly than the measurement point. The TEs of the slower speed meshes appear higher within the FFT of the system angular TE, but are not necessarily higher when recalculated as an individual gear mesh linear TE.

Relationship between noise/vibration and transmission error testing results. A further inspection of both the standard noise and acceleration and detailed system TE test results is instructive in the troubleshooting process. Figure 7 shows results from rig testing of the same unit on the same rig. It can be clearly seen that the characteristic sideband structure seen in the system TE is also present in the acceleration and noise data, thus confirming the underlying assumption that the gear TE generates both the casing acceleration and noise.

Testing and data analysis conclusions. In conclusion, the testing methodology is set out, highlighting the importance of both noise and vibration and transmission error testing. In the next section, we describe the role of CAE in supporting the interpretation of the results and developing solutions to reduce noise.

CAE for Gearbox Noise Reduction

In this section we discuss — using the EV hub drive — how CAE can be used to support noise reduction. Where appropriate, comparisons are drawn between the previous test results and the CAE simulation.

A MASTA (Ref. 1) model has been built to simulate the EV hub drivetrain, as described in the following sections.

Power flow and excitation orders.

Gear-set	Peak-to-peak linear TE (urn)	
	Drive	Coast
First gear stage	1.55	4.16
Second gear stage	3.88	4.24

This has already been covered in the (Noise and Acceleration Testing Results) section. A “power flow-type” model is required to calculate all the component speeds and derive the excitation orders. In particular, we have identified the tooth passing orders for the gear meshes and superimposed them on the noise and TE measurement results. An integrated solution between the software used to analyze the test data and the CAE software proves advantageous for speed and accuracy in performing this operation. In this study the order data from the corresponding MASTA model was exported from MASTA, via an XML file, and imported into SMT’s MEASA software for the analysis of the measurement results. This process enables the automatic identification of excitation orders on the measured data plots (Fig. 3).

System deflection. Simulation and testing show that gear mesh misalignment will both potentially degrade gear contact patches (reducing life) and increase transmission error — and thus noise. A full CAE model is required to model and simulate the deflection under load of the full system. The EV hub model consists of:

- Full gear geometry from which the gear forces can be accurately calculated
- Shafts modeled using finite element beam elements or a 3-D stiffness and mass imported from a full finite element model, where appropriate (e.g., for gear blanks)

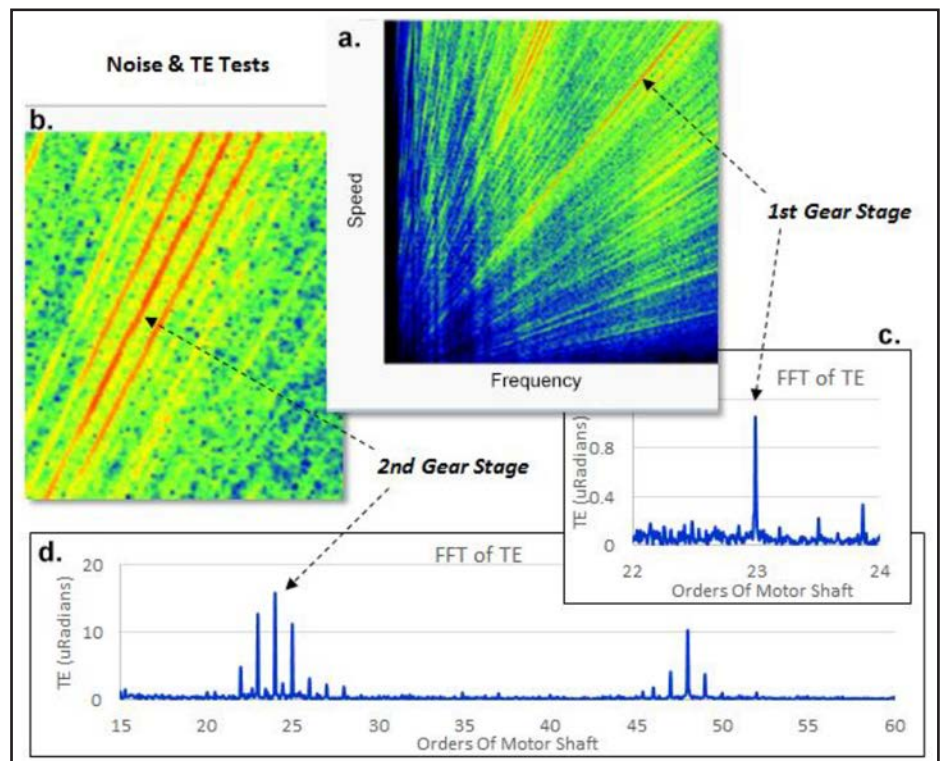

Figure 7 Results showing casing acceleration and transmission error testing results of EV hub drive; same unit with same light load is used for all tests. Detail: (a) waterfall plot of casing acceleration with clear 1st and 2nd stage gear order lines; (b) zoom of second-stage order showing clear sideband structure; (c) and (d) show TE results with respect to these two meshes.

- Bearings modeled using non-linear, load-dependent six-degree-of-freedom stiffnesses, derived using bespoke methods from the bearing internal geometry details and a Hertzian contact model (Ref. 5)
- Casing modeled using 3-D dynamic stiffness and mass reduction imported from a full finite element model

Typical results are given in Figure 8, showing the deflection of the full system; the critical gear mesh misalignments are given in Figure 9. An important role of CAE is that it allows for the simulation and identification of those components which contribute the most flexibility and are thus candidates for optimization (Ref. 6). Figure 9 also includes misalignment results showing the effect of the casing flexibility. For this unit, we can rule out poor bulk casing flexibility as a contributing factor to the noise issue. The model shows that the gear misalignments are due to shaft and bearing deflections under load. A methodology the authors often use in projects is to build further models with stiff/flexible shafts and bearings in order to identify exactly how much misalignment can be attributed to each component. This level of detail is not given here for brevity.

Loaded tooth contact analysis (LTCA). Loaded tooth contact analysis (LTCA) is used to calculate the loaded contact conditions for gears as they progress through the meshing cycle. One critical input for this calculation is the gear mesh misalignment, as calculated in the previous section. The key result with respect to noise is the TE. Torque, misalignment and gear macro- and microgeometry are also used as inputs.

It is important to use an accurate LTCA in order to get an accurate calculation of TE. A hybrid FE and Hertzian contact-based formalism (see Ref. 7 for a formalism similar to that used) is used to accurately capture the stiffness at each contact location, while providing a fast calculation suitable for assessing microgeometry parameter changes and robustness to tolerances (Fig. 10). Such a calculation is comparable in accuracy to a full FE contact analysis, while also being many orders of magnitude faster. An FE model of the gear macrogeometry is built automatically in the

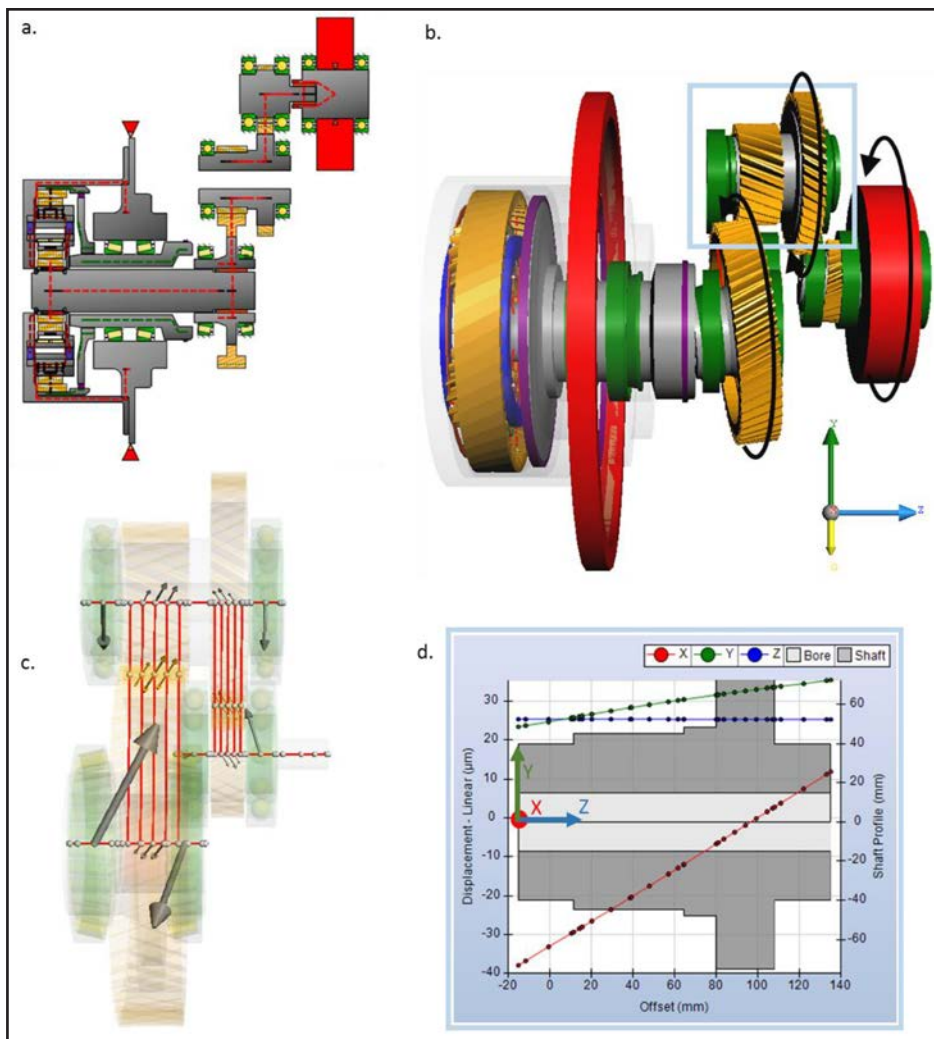

Figure 8 Predicted deflection of EV hub drive. Image a) power flow; b) deflection of full drivetrain; c) gear and bearings loads on first two stages; d) predicted deflection of intermediate shaft 1.

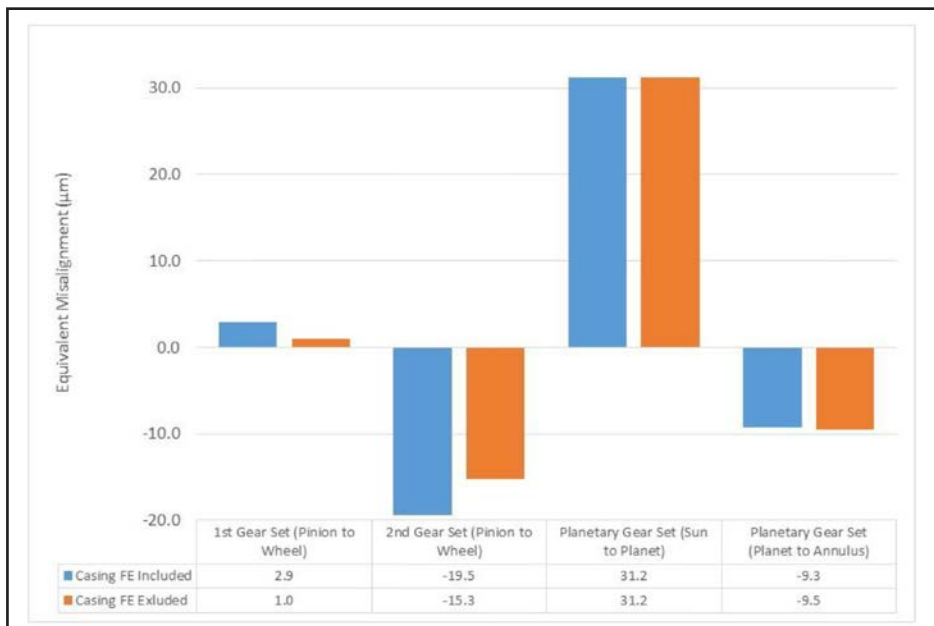

Figure 9 Predicted gear mesh misalignments— with and without including effects of casing stiffness.

software and is used to obtain the overall bending and base rotation stiffness of the gear teeth, with consideration made for coupling between teeth. This bending stiffness is combined with a Hertzian line contact formalism to calculate the overall stiffness of any potential contact points. Potential contact lines are split into strips, and force balance and compatibility conditions are formulated and solved to calculate the load distribution across the mesh and the transmission error for the input torque. This loaded tooth contact analysis can be used to optimize both gear microgeometry and macrogeometry for minimal transmission error. Consideration must be given to the entire operating range of loads and the robustness of the proposed design to variation in load and misalignments, as well as variation in gear microgeometry within the manufacturable tolerance range.

The correlations between test and simulation are often insightful with respect to solving noise issues. If correlation is good, this boosts confidence in the analysis model, implying that calculated misalignments, microgeometry inputs, calculated load distribution and TE are accurate and the model can be taken forward to explore design changes. Conversely, differences between test and simulation can often highlight manufacturing problems. In this case the model showed good correlation for the contact patches (Fig. 11). The TE analysis and test results proved important in highlighting manufacturing issues to be corrected, including the second-stage sideband structure in test and considerably higher measured peak-to-peak TE than predicted from the nominal gear design geometries. There will always be some manufacturing variation with respect to the nominal design, but the increases in measured TE compared to simulation in Figure 12 were judged to be too great, and a thorough audit of manufactured tolerances was undertaken. Poor control of a number of critical tolerances was identified and rectified, yielding improved noise performance.

Advanced system deflection and system TE. A further, more advanced simulation is to combine the LTCA and system deflection calculations — known as “advanced system deflection” (ASD) — in MASTA. In the ASD the LTCA assumption that the misalignment is constant through the meshing cycle is relaxed, the misalignment is recalculated based on the gear load distribution from the LTCA and, conversely, the gear load distribution is recalculated with the corrected misalignment. An iterative solution is followed to reach equilibrium for each meshing position.

In a number of important cases, such as the tooth contact conditions of a planet gear, the interaction between two or more meshes of the planet means that the system deflection and tooth contact conditions are best solved with this coupled ASD calculation. Further, for planetary systems where contact conditions may vary as the planet carrier rotates, such a coupled calculation can be used to calculate the load distribution and transmission error as the planets precess.

For the EV hub, this calculation was used to simulate the full system TE — including gear tooth pitch errors (Fig. 13). The simulation was run with nominal geometry; comparison to test confirmed that the second stage had significant contributions from manufacturing errors, giving a sideband structure.

Modal analysis and gear whine simulation. The full CAE model described above can also be used to analyze the dynamics of the system via modal and harmonic response analyses.

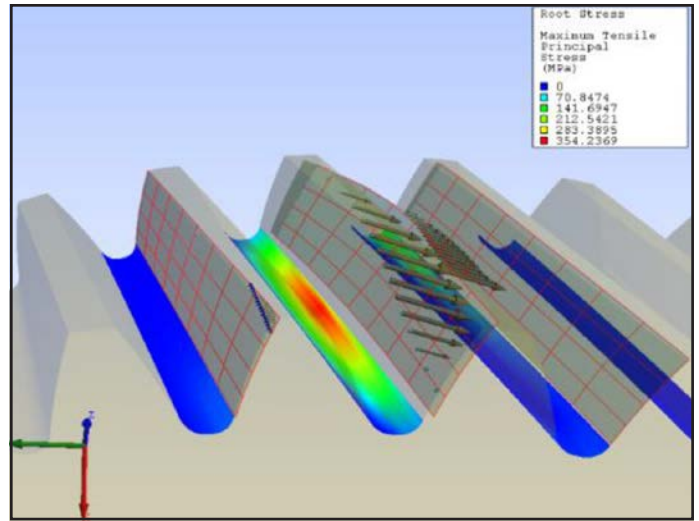

Figure 10 Hybrid FE and Hertzian-based LTCA used to calculate gear mesh load distribution, contact and root stress (shown in this figure for one roll angle) and transmission error, in order to optimize gear geometry for low noise.

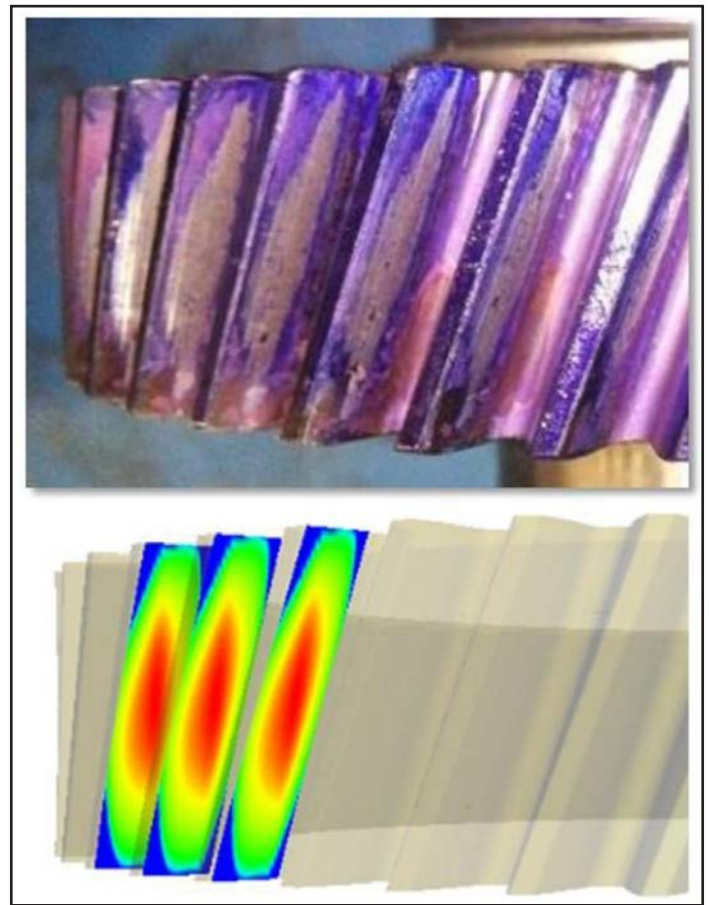

Figure 11 Test and predicted gear contact patch results from EV hub drive.

For Related Articles Search

noise

at www.geartechnology.com

For a modal analysis of the system at a given input load, a linearized model of the non-linear static analysis model is used.

The calculated natural frequencies, mode shapes, modal strain and kinetic energies, and Campbell diagrams can be used to identify potential excitations of the system where, for example, gear mesh frequencies or their harmonics cross the natural frequencies of the system; further inspection of the energy content (strain or kinetic) of the mode shapes can be used to identify the main contributing components to those potential resonances. For example, modes with significant strain energy in the gear mesh modeling element are most likely to be excited by TE. One target would be to minimize the number of natural frequencies within the operating range while also separating any that happen to lie within the range from of each other.

The method of calculation of the system response to the TE introduced by (Ref.8) can be used to calculate the casing acceleration at virtual accelerometer locations. As the excitation is periodic and the stiffness around the loaded condition can be considered linear, calculation can be performed very quickly in the frequency domain. The static TE described above is the assumed excitation input of the system and the first step is to calculate the dynamic force at the gear meshes that leads in turn to a relative displacement at the mesh given by this transmission error. This force is known as the “dynamic mesh force” and is calculated from the dynamic compliances at each side of the gear meshes. The dynamic mesh force is then applied as an excitation to the system model to calculate the response (at any point on the system) to this excitation. Waterfall plots of dynamic response for any point on the model can be shown and compared with accelerometer and/or microphone data obtained via noise and vibration tests.

Figure 14 shows a comparison of test and simulated accelerations on the casing of the EV hub drive. Plots are given here for SPL (sound pressure level) versus speed, which is of most direct interest to a vehicle manufacturer; however, SPL versus frequency plots is also

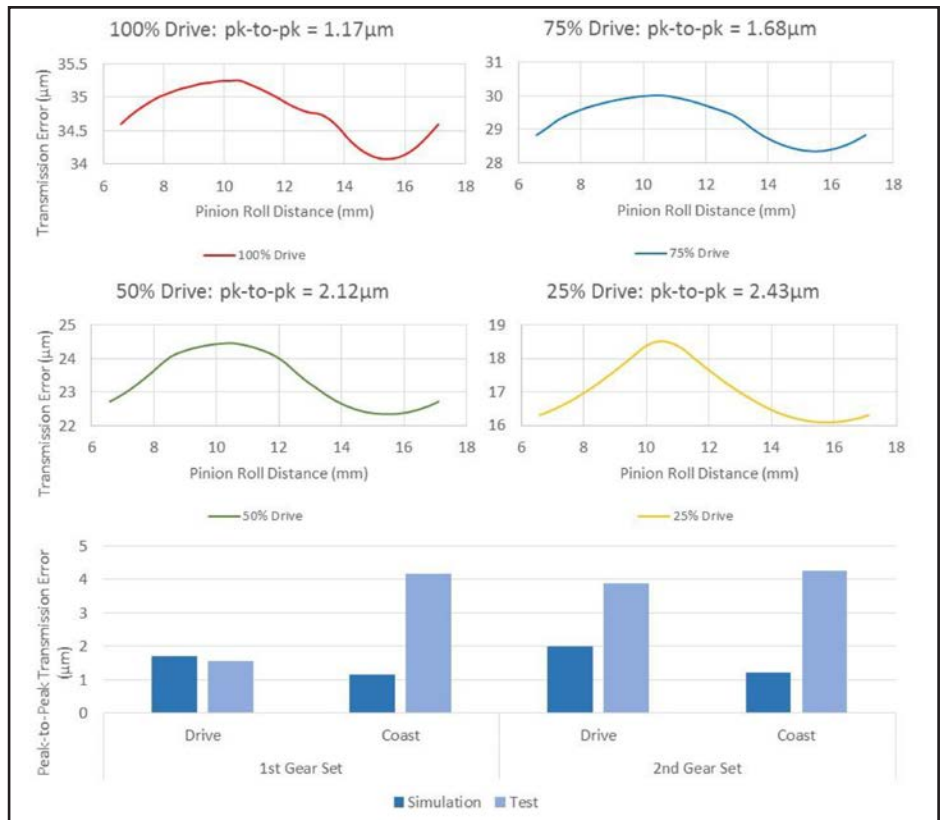

Figure 12 Transmission errors; simulated transmission errors in top four graphs showing sensitivity to load; bottom two graphs show simulation and measurements of rejected hub drive unit—both at light load. 100% drive denotes max motor/input torque over typical drive cycle.

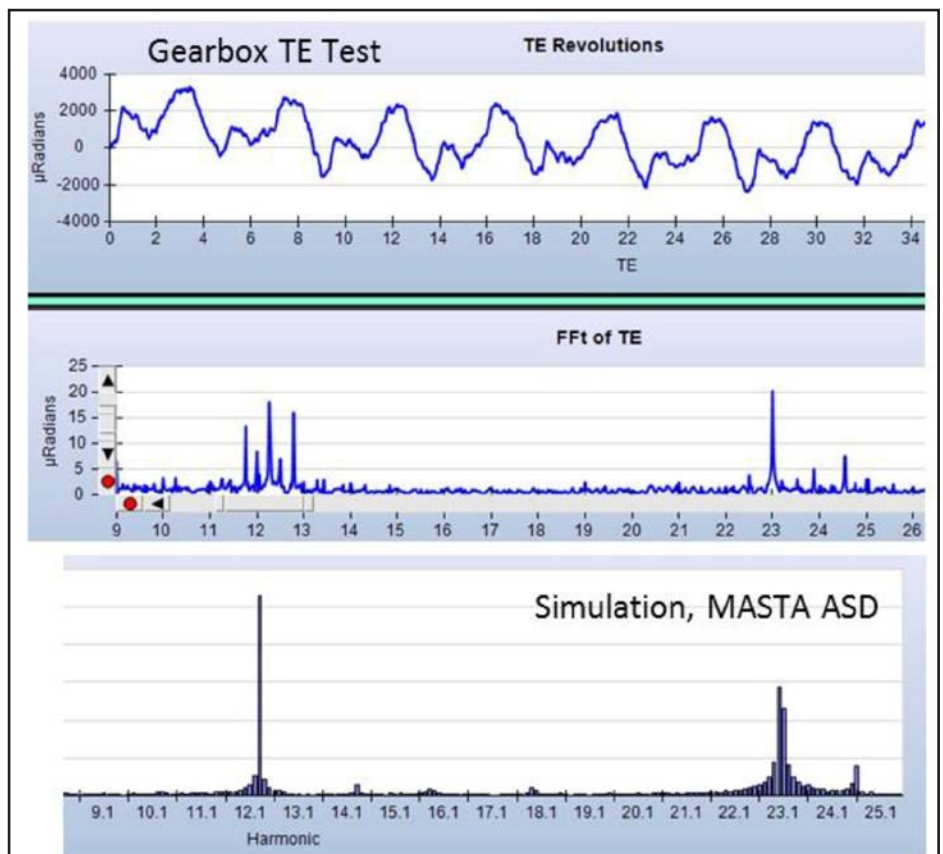

Figure 13 Predicted and test results for full drivetrain system TE.

instructive; e.g., checking for presence of resonances). The results provide a qualitative comparison and were used to guide the troubleshooting team in their noise reduction strategy. As an example, no clear, isolated resonances were identified, suggesting that casing dynamic optimization was not necessarily a good route, but gear geometry optimization, inspection and improvement of manufacturing quality were.

Design optimization for noise reduction. The first stage of the optimization process is presented here; further optimizations are in progress. This first stage focused on redesign of both the gears' macro- and microgeometries to reduce TE. Advanced CAE tools described in the previous sections were used to make the modifications and guide and assess the design improvements (Fig. 15). The main optimization tasks undertaken within this stage can be summarized as follows:

- Assess gear macrogeometry for potential tooth number changes to improve contact ratios while taking care not to move tooth passing frequencies to coincide with any system resonances within the operating range.
- Further macrogeometry optimization of gear module, helix angle, pressure angle, and tooth height to improve contact ratios and minimize predicted TE across full operating range of loads.
- Microgeometry redefinition and optimization again, for minimized predicted TE across full operating range of loads; note that the full MASTA CAE model of the gearbox is used to provide the gear misalignment input to the TE calculations.
- Ensure that predicted durability results are not compromised by the design changes for reduced noise.

The results of prototype testing of this first phase of design changes are given in Figure 16. These in-vehicle noise measurements show significant individual gear noise contribution reductions. Total noise reductions of about 12 dBA, with respect to the peak value across the operating range, have been achieved.

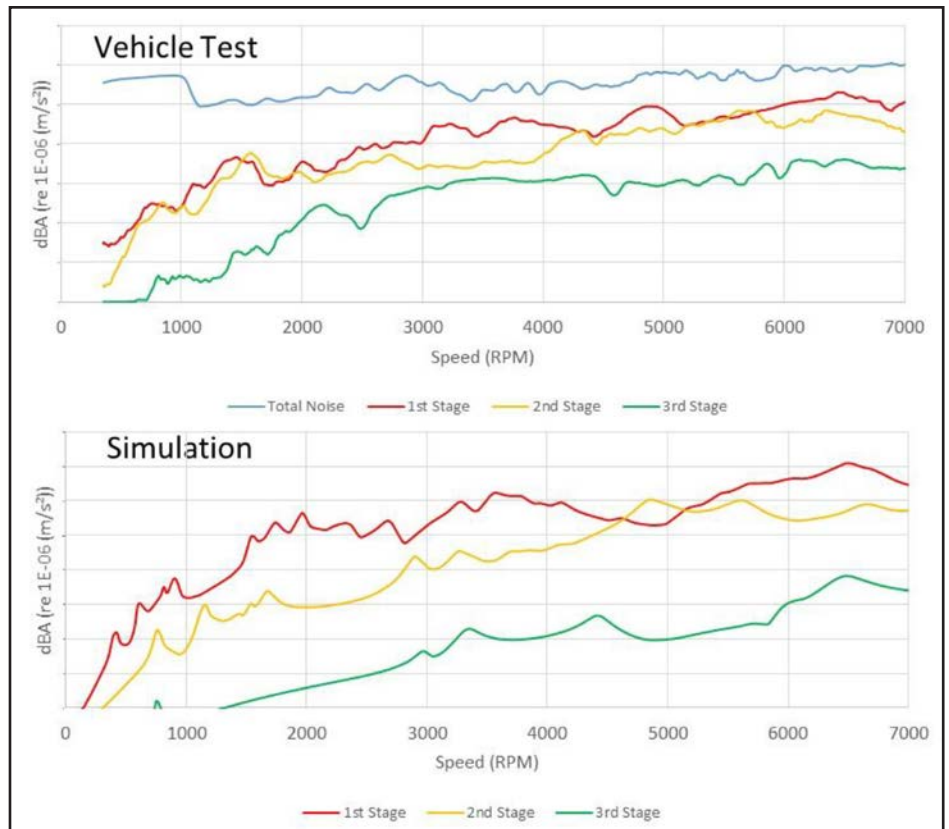

Figure 14 Comparison of test and simulated accelerations on casing of EV hub drive. On the vertical axis, there are 10 dB per division.

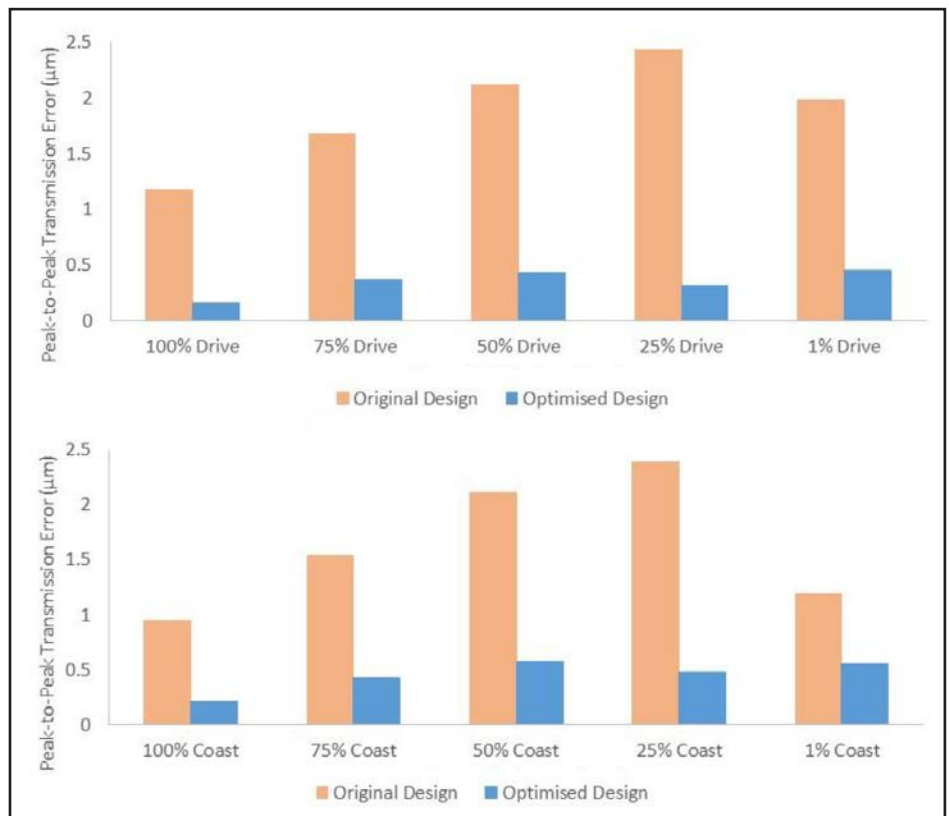

Figure 15 Results for simulated TE for second-stage gearset across full load range—both drive and coast conditions for original and optimized gear designs.

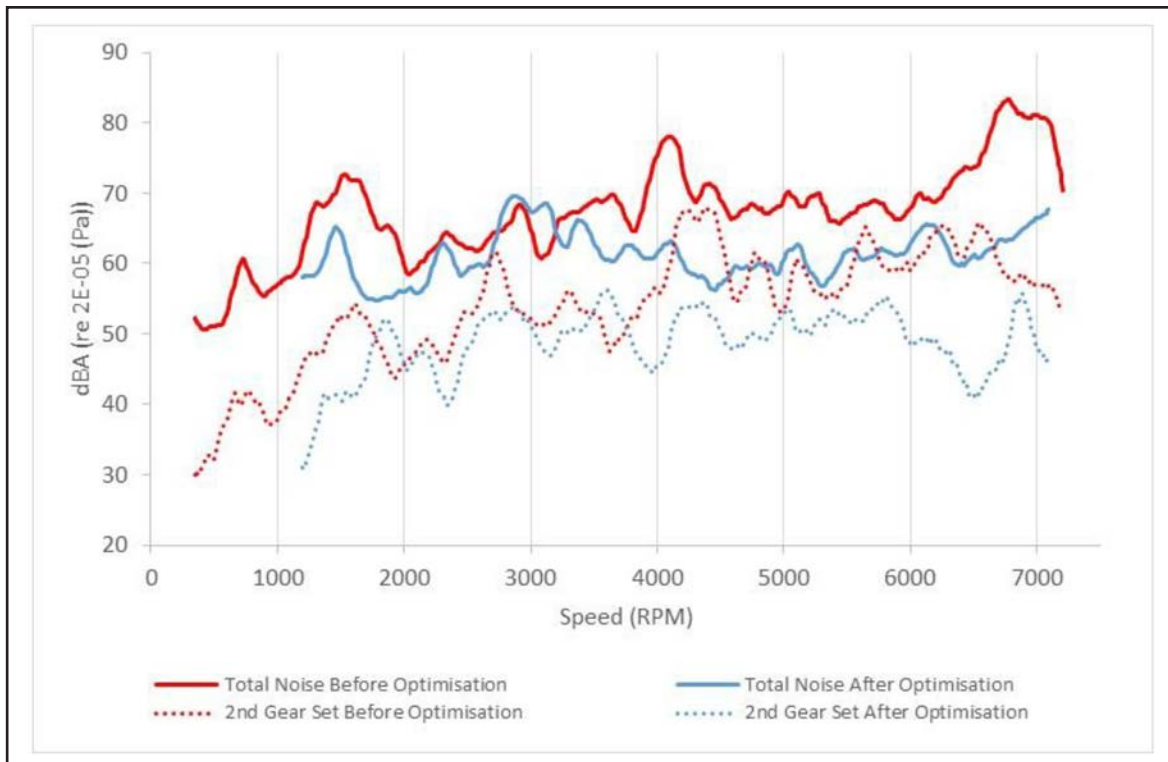

Figure 16 In-vehicle total noise and second-stage noise contribution—before and after a first optimization of EV hub drive; peak value across speed range was 82 dBA in original design and 70 dBA after optimization.

Conclusions and Future Work

This paper describes how gear-related NVH issues can be important during the development of EV and HEVs. It describes how a strong combination of testing and CAE tools, together with a solid methodology, can provide efficient solutions for such issues. A system-level approach to both processes is recommended to fully capture the interactions of all components. A case study of a hub drive for an electric bus was presented, showing how such an approach led to significant noise reductions within a first round of design optimizations.

Some of the authors' future work will be focused on further integration of test data analysis and CAE simulation tools, so more rapid comparison of test and simulation results can be made. ⚙️

References

1. Smart Manufacturing Technology Ltd. *MASTA and MEASA software*, www.smartmt.com, 2015.
2. Smith, J.D. *Gear Noise and Vibration*, Second Edition, Marcel Dekker, Inc. 2003.
3. Houser, D.R. et al. "Determining the Source of Gear Whine Noise," *Gear Solutions*, February 2004.
4. Inalpolat, M. and A. Kahraman. "A Theoretical and Experimental Investigation of Modulation Sidebands of Planetary Gear Sets," *Journal of Sound and Vibration*, 2009.
5. Harris, T.A. "Rolling Bearing Analysis," 3rd Ed., John Wiley & Sons, Inc., 1991.
6. Harris, O.J. et al. "Predicting the Effects of Housing Flexibility and Bearing Stiffness on Gear Misalignment and Transmission Noise using a Fully Coupled Non-Linear Hyperstatic Analysis," *Proceedings, Institution of Mechanical Engineers*, C577/005/2000, May 2000.
7. Steward, J.H. "Elastic Analysis of Load Distribution in Wide Faced Spur Gears," PhD thesis, Newcastle University, 1989.
8. Chung, C., G. Steyer et al. "Gear Noise Reduction through Transmission Error Control and Gear Blank Dynamic Tuning," *SAE Noise and Vibration Conference 1999-01-1766*.

Dr. Owen Harris, a graduate of Trinity College Cambridge, has worked in the analysis of transmissions and geared systems for over fifteen years. He was instrumental in writing some of the first commercial software codes for housing influence, system modal analysis and gear whine and planetary load sharing. Harris has filled many roles in over ten years working at Smart Manufacturing Technology Ltd. (SMT). He has worked on SMT's state-of-the-art MASTA software, while at the same time being heavily involved in many engineering projects. Harris's current focus is to lead SMT's research department.



Dr. Paul Langlois is the CAE products development department manager at SMT. Having worked for SMT for 10 years, he has extensive knowledge of transmission analysis methods and their software implementation. He manages the development of SMT's software products and is a main contributor to many aspects of the technical software development. As a member of the BSI MCE/005 committee, Langlois contributes to ISO standards development for gears.



Gareth A. Cooper is a graduate of Loughborough University's automotive engineering department. He has been involved in many automotive NVH projects providing testing, CAE analysis, and solution implementations. Cooper heads up SMT's engineering team to deliver SMT's NVH software and hardware solutions as product and engineering services.



Rules for Optimal Basic Design of Bevel Gears

Dr. Hermann J. Stadtfeld

Bevel Gear Technology

Chapter 6

Introduction

More strength and less noise are the two major demands on gears, which includes both bevel and hypoid gears. Within the last few years, the still modest request for higher efficiency has been added to the original two requirements. Traditionally, gear engineers have met the first demand by changing a gearset's basic parameters — tooth height, pressure angle, spiral angle, etc. — and to meet the second, by making flank form modifications in order to reduce crowning — also known as “Ease-Off.”

With today's available bevel gear software — e.g., *CAGE* and *UNICAL* — many engineers are modifying flank topography and discovering their gearsets are both stronger and quieter. Unfortunately, this coincidence is tricking some engineers into believing that Ease-Off itself adds strength to gearsets. In fact, the flank form modifications are only allowing the sets to make greater use of the strength potential that was available in their basic designs.

Most strength optimization requires changing a gearset's basic parameters. Most minor reductions in gear noise are made by optimizing just flank topography. In some cases, though, there are gearsets that don't use all their possible strength because they need more sophisticated Ease-Offs, which are adjusted to the particular operating conditions. The challenge for gear engineers is to know when to change what — basic parameters or flank topography — to increase a gearset's strength. In order to make such a distinction it is necessary to understand both basic parameters and flank form modifications (Refs. 1 – 2).

Although the influence of the basic parameters seemed to be obvious in the past, today's calculation and analysis sys-

tems provided many new insights. These new insights occasionally seemed to contradict the general experiences and appeared physically inconclusive. It is interesting to note that the implication of the “deeper” analysis and their physical basics can often only be discovered after intensive studies. The results are significantly improved gear properties which can be materialized for the first time today.

This chapter opens with a closer look at the so called “dimension sheet.” The Gleason Dimension Sheet has become a

workload standard, although at first view it does not appear to be very “user-friendly.” It includes (in a highly condensed layout) all important basic dimensions, as well as many parameters that are not explicitly expressed in the geometrical data of a bevel gearset. The following sub-chapters elaborate each on one of the key gear parameters, with recommendations that comply with good practices in advanced bevel and hypoid gear design. The end of this chapter discusses the question, what can be achieved with more optimal dimension sheet param-

THE GLEASON WORKS									
Division of Gleason Corporation									
HYPOID GEAR DIMENSIONS			NO.	M	SAMPLE	VERSION: 1.0.4.3		1/16/2012 8:25	
GLEASON					PINION		GEAR		
NUMBER OF TEETH		12		41					
PART NUMBER									
MODULE		4.724							
FACE WIDTH		37.12		30.00					
PINION OFFSET	BC	38.10							
PRESSURE ANGLE - PIN CONCAVE		15D 26M							
PRESSURE ANGLE - PIN CONVEX		26D 32M							
LIMIT PRESSURE ANGLE		6D 21M							
SHAFT ANGLE		90D 0M							
TRANSVERSE CONTACT RATIO		1.036							
FACE CONTACT RATIO		2.074							
MODIFIED CONTACT RATIO		2.318							
OUTER CONE DISTANCE		125.30		103.26					
MEAN CONE DISTANCE		106.71		88.17					
PITCH DIAMETER				193.68					
ADDENDUM		7.83		1.91					
DEDENDUM - THEORETICAL		3.48		9.16					
WORKING DEPTH		10.11		9.78					
WHOLE DEPTH		11.31		11.07					
OUTSIDE DIAMETER		95.12		195.01					
CUTTER RADIUS		3.750"							
SYN. BACK GEAR POINT WIDTH			0.070"						
CALC. GEAR FINISH. PT. WIDTH			0.070"						
GEAR FINISHING POINT WIDTH			0.070"						
PINION ROUGHING POINT WIDTH			0.075"						
OUTER SLOT WIDTH			0.084"						
MEAN SLOT WIDTH			0.084"						
INNER SLOT WIDTH			0.084"						
FINISHING CUTTER BLADE POINT STOCK ALLOWANCE			0.050"						
			0.009"						
MAX. RADIUS - CUTTER BLADES			1.650mm						
MAX. RADIUS - HUTLATION			1.750mm						
MAX. RADIUS - INTERFERENCE			1.625mm						
CUTTER EDGE RADIUS			1.500mm		1.000mm				
CUTTER BLADES REQUIRED	STD	DEPTH	STD	DEPTH					
DUPLEX SUM OF DEDENDUM ANG									
MAX. NO. OF BLADES IN CUTTER									
RATIO OF INVOLUTE/OUTER CONE			1.332						
RATIO OF INVOLUTE/MEAN CONE			1.560						
GEAR ANGULAR FACE - CONCAVE			18D 46M						
GEAR ANGULAR FACE - CONVEX			20D 52M						
GEAR ANGULAR FACE - TOTAL			22D 16M						
ALL DIMENSIONS ARE METRIC UNLESS OTHERWISE SPECIFIED									
RELEASED BY -				AJN					
PITCH APEX BEYOND CROSS PT						25.40		-2.97	
FACE APEX BEYOND CROSS PT.						15.99		-4.72	
ROOT APEX BEYOND CROSS PT.						28.32		-1.25	
CROWN TO CROSSING POINT						90.80		37.03	
FACE ANG TUNCT TO CROSS PT									
FRONT CROWN TO CROSS. POINT						56.90			
MEAN NORMAL TOPLAND						1.76		2.73	
PITCH ANGLE						1.8D 33M		69D 41M	
FACE ANGLE OF BLANK						2.4D 0M		71D 40M	
INNER FACE ANGLE OF BLANK									
ROOT ANGLE						1.6D 42M		63D 44M	
OUTER SPIRAL ANGLE						51D 34M		30D 54M	
MEAN SPIRAL ANGLE						50D 17M		25D 26M	
INNER SPIRAL ANGLE						50D 49M		20D 5M	
HAND OF SPIRAL								RH	
DRIVING MEMBER								PH	
DIRECTION OF ROTATION-DRIVER								REV	
BACKLASH	MIN		0.13	MAX		0.18		NON-GENERATED	
GEAR TYPE									
DEPTHWISE TOOTH TAPER						DPLX			
FACE WIDTH IN PCT CONE DIST								29.051	
DEPTH FACTOR - K								4.200	
ADDENDUM FACTOR - C1								0.180	
OFFSET ANGLE						8D 26M		23D 37M	
GEOMETRY FACTOR-STRNGTH-J						0.2833		0.2922	
STRENGTH FACTOR - Q						7.64202		2.68355	
EDGE RADIUS USED IN STRENGTH						1.500mm		1.000mm	
CUTTER RADIUS FACTOR - KC						1.000			
FACTOR	MM		0.7945						
STRENGTH BALANCE DESIRED						CIVN			
STRENGTH BALANCE OBTAINED								0.148	
GEOMETRY FACTOR-DURABILITY-I						0.2325			
DURABILITY FACTOR - Z						3420.22		1850.35	
GEOMETRY FACTOR-SCORING -G									
SCORING FACTOR - X								93.703	
EFFICIENCY AT 30000 PSI								0.00396	
PROFILE SLIDING FACTOR						0.00359		0.00396	
LENGTHWISE SLIDING FACTOR						0.00689		0.01735	
RESULTANT SLIDING FACTOR						0.00777		0.01767	
AXIAL FACTOR - DRIVER CW	OUT		0.947	OUT		0.020			
AXIAL FACTOR - DRIVER CCW	IN		0.581	OUT		0.217			
SEPARATING FACTOR-DRIVER CW ATT			0.070	SEP		0.173			
SEPARATING FACTOR-DRIVER CCW SEP			0.894	ATT		0.056			
INPUT DATA									
SPIRAL ANGLE						49.60D			
INPUT DATA						RTT/CUTM		72DS	
CLEARANCE FACTOR						1.150			
CALCULATED GEAR PITCH ANGLE 69.685D									
NUMBER OF BLADE GROUPS									
EFFECTIVE CUTTER RADIUS									
SLOT WIDTH PCT FOR BLADE PT.									

Figure 1 The most important gear parameter in the dimension sheet.

ters and should not be subjected to tooth contact optimization and vice versa. The basic dimensions are “locked in” after a gearset is in service and certain optimizations which are traditionally subject of improved basic dimensions can be achieved with changes in the contact geometry. The summary chapter gives recommendations of what can be done in such a conflict.

Influence of the most important parameters. A gearset’s basic parameters establish the potential of its properties which include strength and noise as well as efficiency. There are many major basic parameters, and each of them has a variety of effects upon the operating performance of a gearset. Gear engineers who practice gear design and optimization, and who must value the physical properties of bevel and hypoid gearsets, need to understand these effects — especially when optimizing gearsets. Figure 1 shows a Gleason Dimension Sheet of a typical automotive hypoid gearset. The parameters with the most influence are highlighted in yellow (Ref. 3).

The individually marked parameters are discussed in the order with which they are listed in the dimension sheet.

Module. A fine pitch gear pair results in a larger transverse contact ratio than in that of a comparable coarse pitch system. The reason is the increasing number of teeth in case of a smaller module and same pitch diameter, which will for an infinite number of teeth eventually deliver the relationships of a generating rack. The theoretical contact ratio of two engaged racks is infinite. Smaller modules deliver proportionally shorter and thinner teeth than larger modules in case of same pitch diameters. Fine pitch gearsets generate less vibration and noise, but also have a lower power density. The analogy for better comprehension of this phenomenon is the following: If a cantilever beam is split from its profile height into two halves, and the two thinner beams are packaged above each other like the leaves of a leaf spring, then the load carrying capacity of the beam package (same outside dimensions) is only 25% of the original beam. If now the length of the beam package is shortened to half the

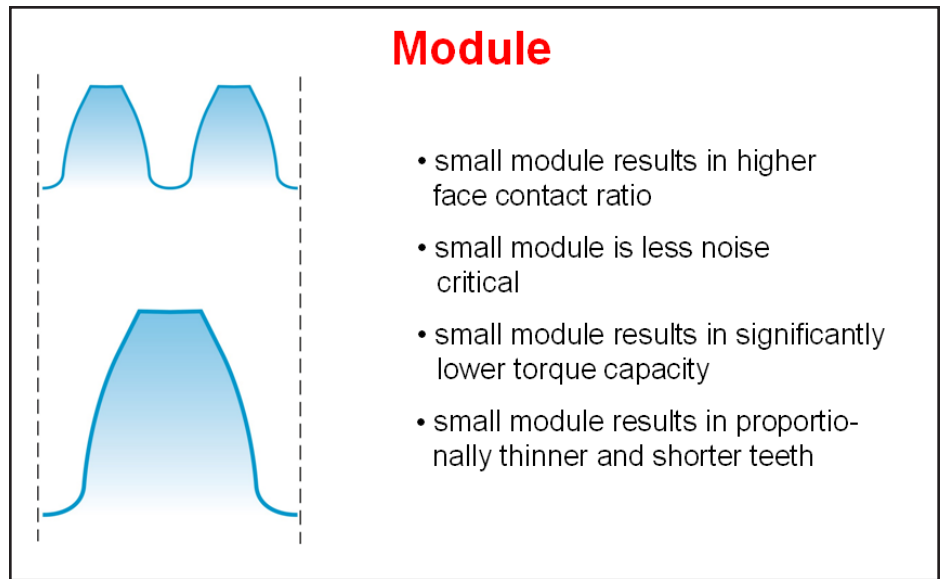

Figure 2 Influence of module.

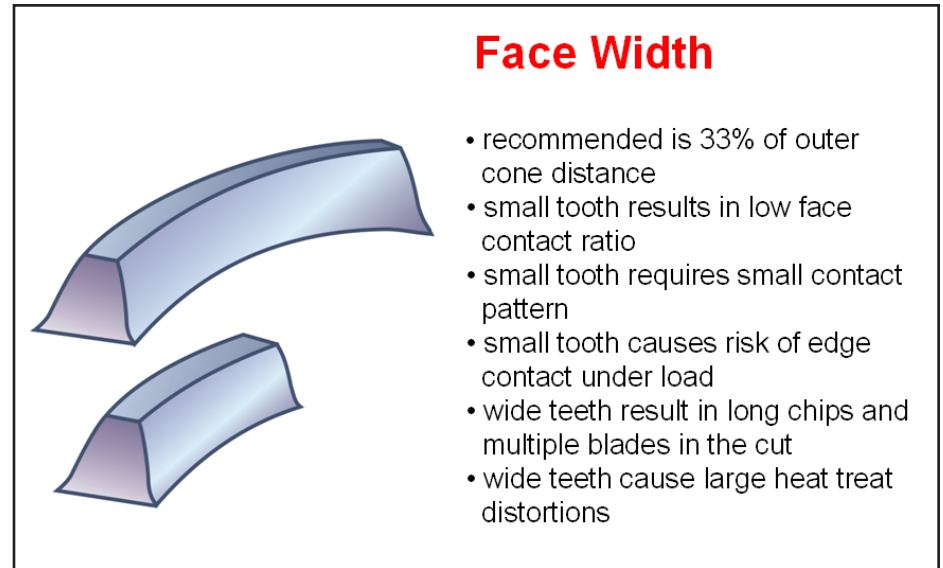

Figure 3 Influence of face width.

length, then the load carrying capacity is 50% of the original. Figure 2 summarizes the major influence of a reduction in module.

Face width. A smaller face width delivers a smaller face contact ratio and requires a small tooth contact. There is a constant risk of edge contact at heel and toe, even with small load-affected deformations. In the case of an oversize face width, problems in manufacturing might occur, as the chips in the soft cutting process are too long and heat treat distortion of the long spiral shaped teeth are significant. In addition, a hard finishing by grinding is problematic because of the long contacting zone between teeth and grinding wheel, which in turn leads to higher risk of burning (struc-

tural damage and soft spots along the face width and in the root). The expected strength increase due to a wider tooth is not achieved because a uniform load distribution is less likely to be realized if the face width is increased above the recommended numbers. The optimal face width for bevel and hypoid gearsets is 33% of the mean cone distance; Figure 3 summarizes the most important influences of the bevel gear design parameter face width.

Point radius of cutting blade or grinding wheel. The maximal radii that can be ground on the tip of a cutting blade are limited by the point width of the cutter and the top width of the blade (Figure 4). Blades with a small clearance side edge radius, e.g. — a sharp clearance side

corner — can cause mutilations in the root fillet side, which is not “officially” machined by the observed blade (Fig. 6).

Hypoid offset. A hypoid offset is generally used for rear wheel driven passenger cars in order to lower the center of gravity and to avoid a bigger propeller shaft tunnel. The hypoid offset causes a relative length sliding between the meshing flank surfaces and enlarges the diameter and spiral angle of the pinion. This leads to better hydrodynamic lubrication, additional dampening in the tooth mesh, increased contact ratio, and improvement in pinion strength.

The gear engineer should design bevel gears with an offset whenever possible — especially small offsets that achieve the desired advantages without the potential disadvantages that the hypoid offset can produce. Even a very small offset helps to avoid pitting population along the pitch line, as they are known in spiral bevel gears. The possible disadvantages of hypoid offsets, above 5% of the ring gear diameter, are the required use of hypoid oils with additives and the potential for scoring during the break-in period of the gearsets. Hypoid gears with offsets above 20% of the ring gear diameter show a low efficiency and an increased operating temperature. The optimal hypoid offset lies between 10% and 15% of the ring gear diameter. Hypoid gears with optimal offsets are superior to spiral bevel gears with regard to strength, quiet operation, and efficiency. Hypoid gears also have the lowest operating temperatures, compared to other angular transmissions. Figure 7 contains a summary of the most important influences of the hypoid offset.

Pressure angle. A reduction of the pressure angle increases the topland and width of the root fillet. A pressure angle reduction is a welcome freedom if an increase of the topland or the root fillet is required in the course of a gearset optimization. This often results in a natural combination of depth and low pressure angle, as it is used in well proportioned “high tooth designs.” Suitable standard pressure angles are 20°. In the past, bevel and hypoid gears often used 22.5° in order to achieve higher gearset strength. Today’s tools like flank optimization with

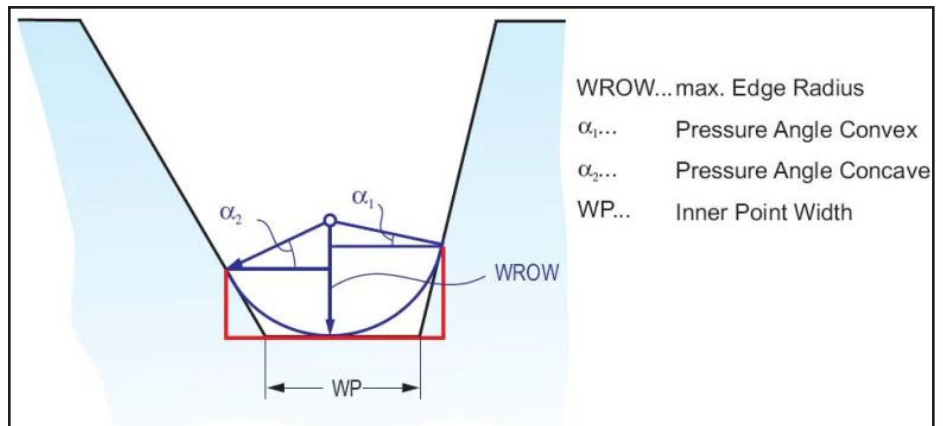

Figure 4 Maximal geometrically possible blade edge radius.

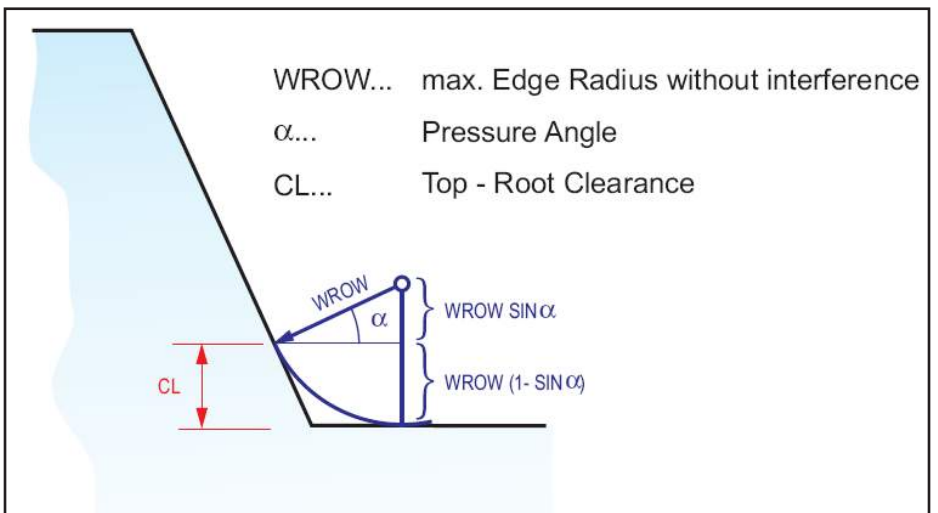

Figure 5 Interference limit for maximal blade edge radius.

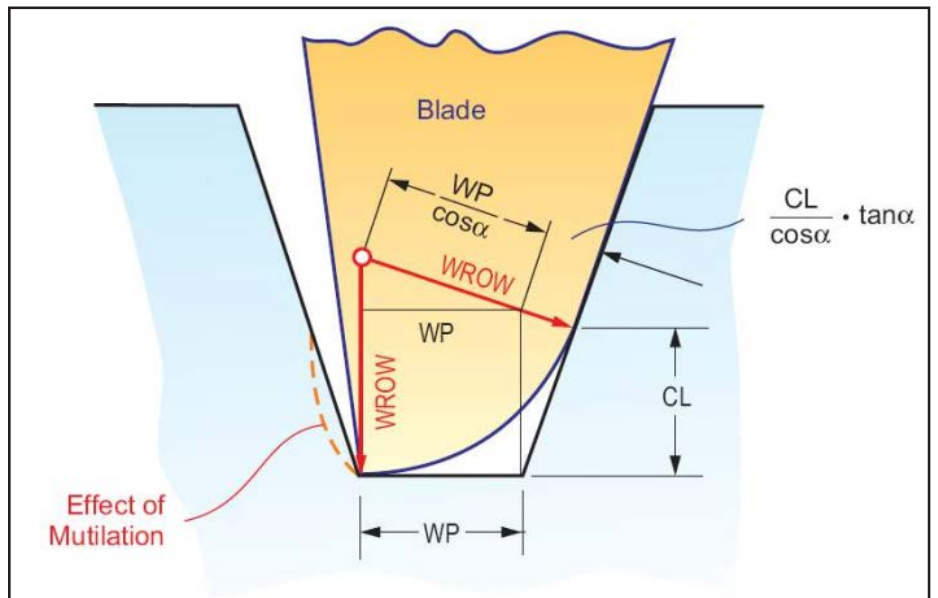

Figure 6 Mutilation limit of opposite root fillet due to edge radius.

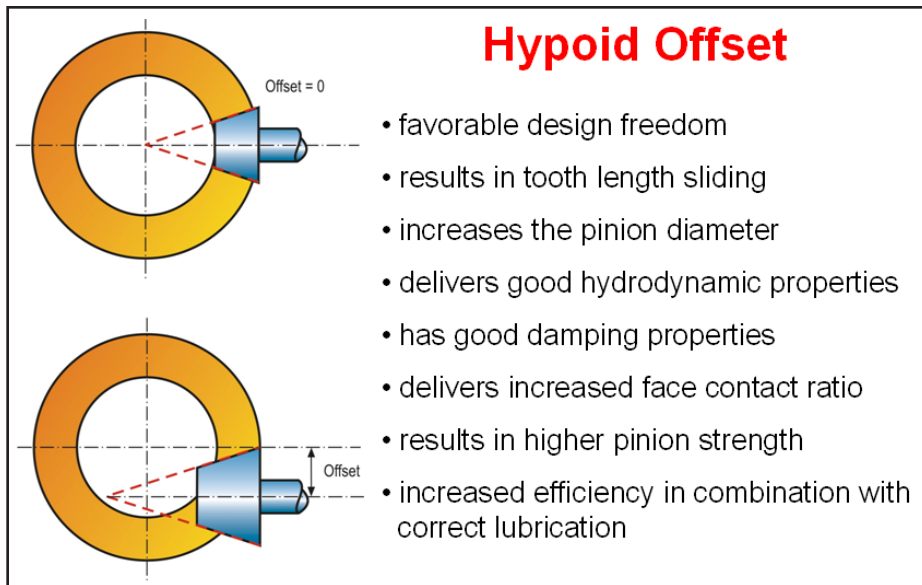

Figure 7 Influence of hypoid offset.

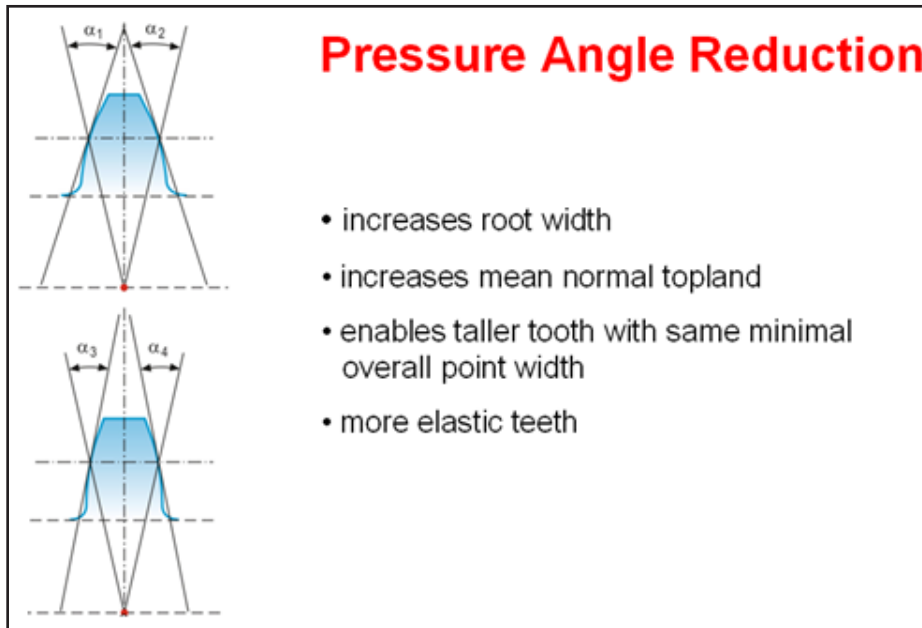

Figure 8 Influence of pressure angle.

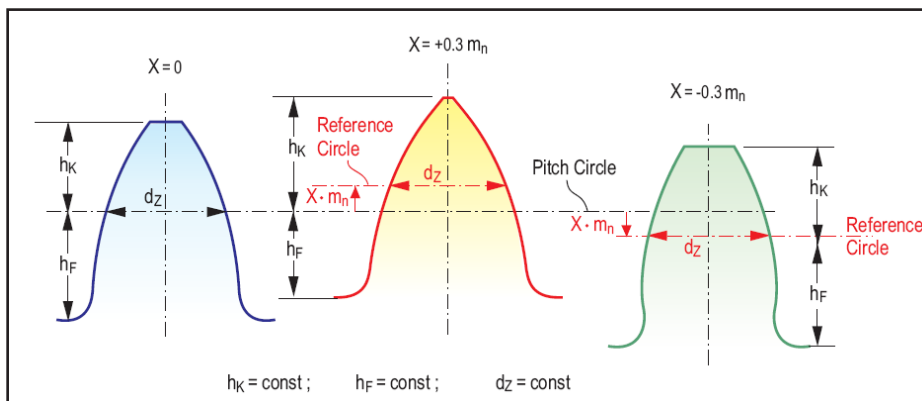

Figure 9 Influence of profile shift.

UMC (Universal Motion Concept; see original text chapter 16) and strength analysis with finite element calculation allow for a better utilization of the tooth elasticity, resulting in a better load sharing.

Subsequently, many quiet bevel and hypoid gearsets today, with high power density feature a large whole depth and low pressure angles. The recommendation for bevel and hypoid gears is to apply an included pressure angle between 36° and 40° . The most important influences of the pressure angle are summarized in Figure 8.

Profile shift. The profile shift (or addendum modification) is used in order to improve the roll conditions (increase of active profile) and to avoid undercut in the pinion root. The resulting pitch line for spiral bevel gears with a ratio above 1x2 lies towards the pinion root. The pinion root shift towards the pitch line is even more significant for hypoid gears, often with the goal to keep the vector summation of profile and length sliding low. The center graphic in Figure 9 shows the reduction of top-land and root fillet could be reversed by reducing the pressure angle; but this in turn would also reverse the improvement in roll conditions and increase the undercut again. In the case of form-generated sets it is possible by means of a tooth thickness balance to increase the pinion top-land and reduce the gear top-land by nearly identical amounts since the Formate gear will not change its profile due to a profile shift. This however will reduce the root width of the pinion, which presents another limitation. In many cases a compromise between small pressure angle reductions and minimal tooth thickness balance can be struck in realizing the desired profile shift.

Whole depth. A taller tooth has more elasticity than a tooth with the standard depth of about $2.2 \cdot m_n$. The larger whole depth is achieved by an involute extension at the top and a deeper cutting at the root. The root tooth thickness will change little or not at all. Advantages of taller teeth are the increased transverse contact ratio, the lower intensity of the meshing impact and better load sharing

between adjacent teeth due to the higher elasticity. Within certain limits this means that more tooth bending leads to reduced bending stresses in the root fillet area, which can be verified with finite element calculation (load sharing). In summary, there are strength and noise advantages without disadvantages regarding the function of a gearset. The most important influences of an increased whole depth are summarized in Figure 10. Usual limits

for bevel and hypoid gears are a minimal whole depth of $0.8 \times$ module and a maximal whole depth of $1.2 \times$ module.

Cutter radius. A small cutter radius increases the contact ratio of a bevel and hypoid gearset. The reason is the spiral angle, which increases faster towards the heel in the case of a small cutter radii. Load-affected deformations cause tooth contact movement towards the heel, that causes an increase of the con-

tact ratio while the load rises. The larger spiral angle also reduces the tooth contact movement and the contact spread in heel direction under load that presents a “natural” protection effect; this effect is amplified with smaller cutter radii and reduced if larger cutter radii are used.

In an ideal design the contact pattern without load is positioned towards the toe. A cutter radius should be selected so that a certain contact movement — under load towards the heel — occurs, while at the same time the contact pattern spreads in tooth length direction. In this ideal scenario the contact pattern at nominal load extends over the entire face width — without causing edge contact on heel and toe. The mean point movement towards the heel with increasing load, and the natural opposing of this movement due to the increasing spiral angle, leads to a defined load concentration in the heel area. The load carrying capacity can be significantly increased if the optimal cutter radius is chosen, as the tooth root thickness at the heel is often 50% larger than tooth thickness at the toe. The root bending stresses of bevel and hypoid gears with an optimized cutter radius are quite uniform along the face width; the most important influences of the cutter radius are summarized in Figure 11.

Relationship between involute point and mean cone distance. This section offers a basic explanation of the dependency between the cutter radius and the displacement behavior of spiral bevel and hypoid gears that was discussed in the last section. Load-affected deformations and inaccuracies in the building position of a bevel or hypoid gearset cause a tooth contact movement in the direction of a certain point within or outside of the face width. This point is located where the flank length curvature is equal to the curvature of an involute along the face width. This requirement would be fulfilled in every point along the face width — if the flank line was an involute. Circles or epicycloids fulfill this requirement only at one point, which can lie within or outside of the face width. The base circle radius of this virtual involute is, in the case of face milling, the distance from the generating gear center to the center of the

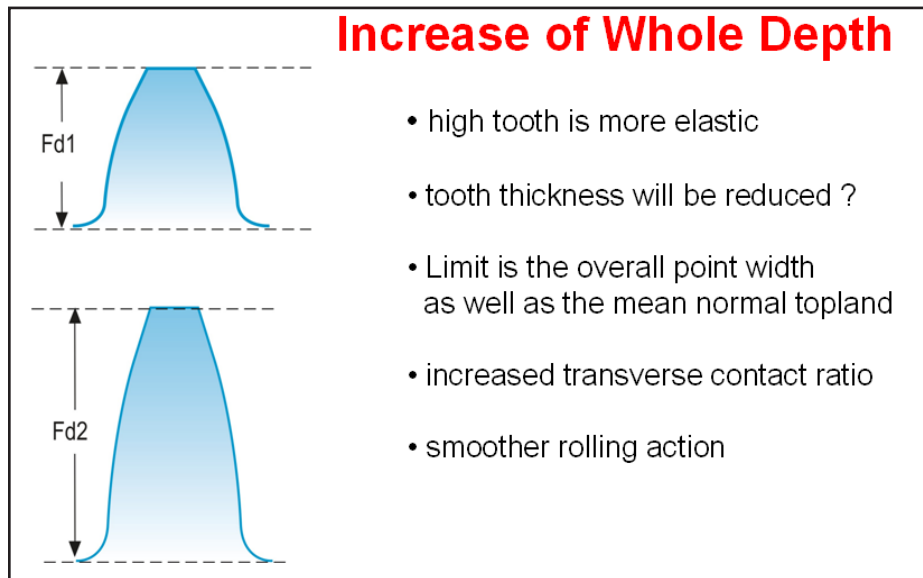

Figure 10 Influence of whole-depth.

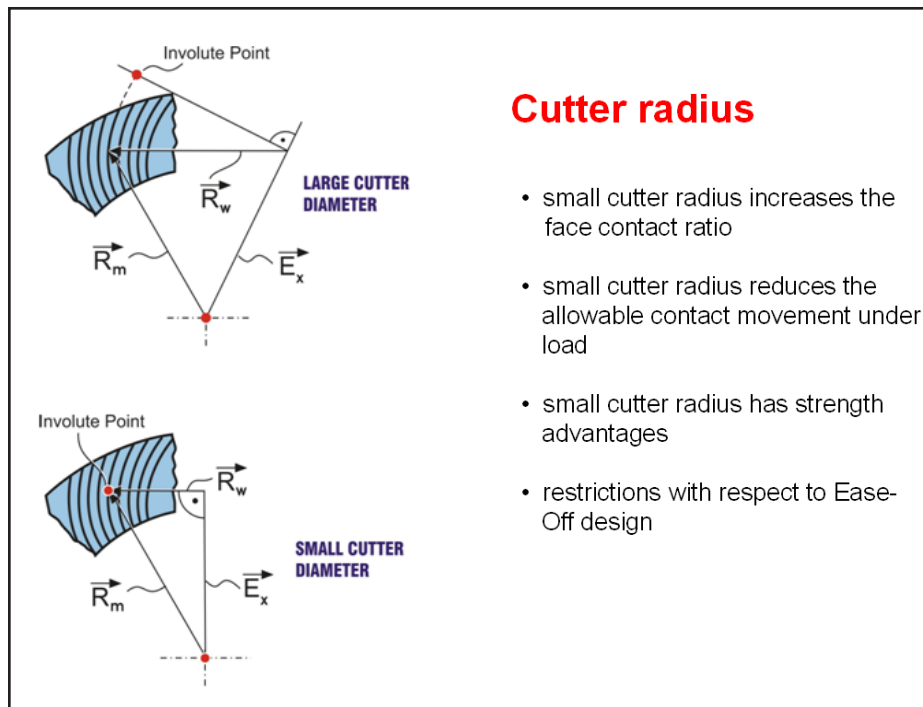

Figure 11 Influence of cutter radius.

cutter head. In the case of face hobbing, the base circle of the extended epicycloid is also the base circle of the involute (see also original text, chapter 2). The connection between the base circle roll point and any chosen point along the flank line is the radius of curvature at this chosen point. If the vector of the curvature radius is oriented tangential to the base circle, a flank curvature is then generated identical to the involute curvature. Figure 12 can explain the relationships for both bevel gear types — face milling and face hobbing.

Smaller cutter radii are at mid-face or in the toe area, rather than perpendicular to the radial distance (i.e. the base circle single indexing i.e. continuous indexing method). Larger cutter radii lead to involute points at larger diameters. The ratio A_x/A_m is documented in the dimension sheet (see Fig. 1). A value of 1 for A_x/A_m results in an involute point at mid-face of the teeth, meaning that no contact pattern movement under load-affected deformations will occur. This is analogous to the center distance insensitivity of cylindrical gears (see original text chapter 1). Although this appears desirable initially, a contact pattern that will not move under any conditions will cause early surface fatigue in the region of the design point (in the flank center). This problem begins to show by evidence of a growing pitting population that can eventually result in flank fracture. The ideal location of the involute point in modern, highly optimized bevel gears is in the middle — between flank center and heel. Recommended values to achieve deflection insensitive gearsets are:

$$1.14 < A_x/A_m < 1.2 \text{ and } 0.92 < A_x/A_o < 1.05. \quad (1)$$

Spiral angle. The spiral angle is, per definition, at the center of the face width. A large spiral angle reduces tooth thickness and increases the maximal-possible face contact ratio. The reduced tooth thickness has a quadratic influence on the root bending stress, which reduces the root strength significantly. In contrast, the face contact ratio increases by the $\tan \beta$ of the introduced spiral angle, resulting in a load sharing of additional tooth pairs. Theoretically, the latter effect

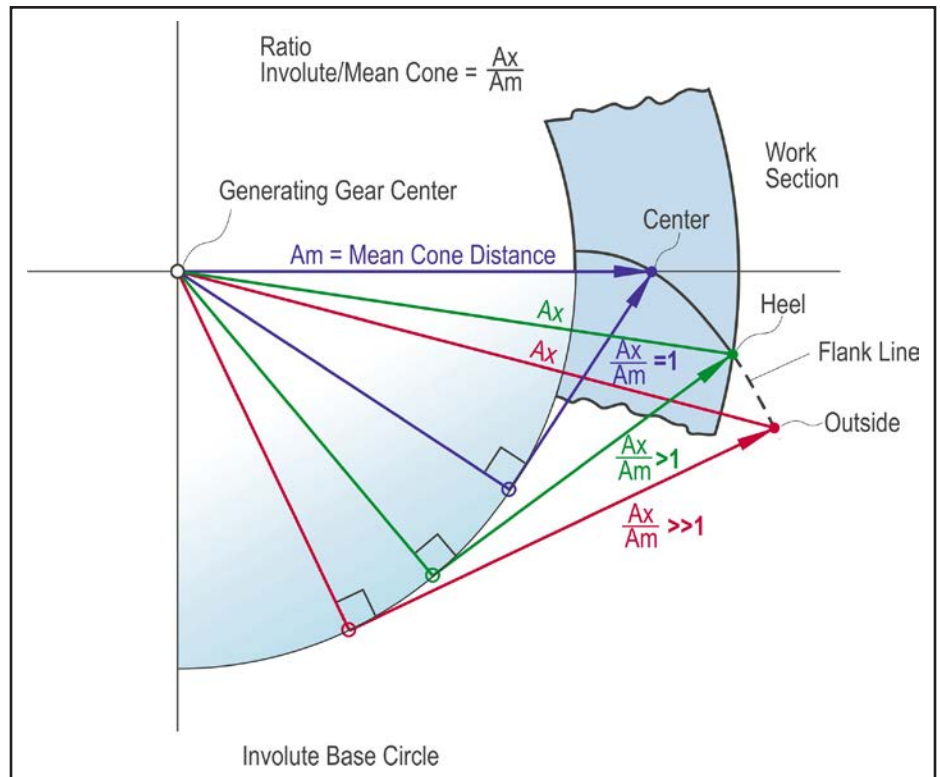

Figure 12 Relationship of involute radius to mean cone distance.

Spiral Angle Increase

- reduced the tooth thickness
[$\sigma = MW / W ; W = (b \cdot h^2) / 6$]

where:

- σ ...root bending stress
- M...bending moment
- W...moment of inertia
- b...face width
- h...tooth root thickness

- increases face contact ratio
- reduces excitation due to tooth mesh impact

Figure 13 Influence of spiral angle.

increases the root bending strength more than the reduction that occurred due to the smaller tooth thickness (Fig. 13). The load carrying capacity of a straight bevel gearset can theoretically increase with the introduction of 30° spiral angle by 18% (see also original text chapter 4.3.4).

But the reality is that only a small percentage of the load is transmitted by the

neighboring teeth due to the flank crowning. Non-hard-finished bevel gearsets that undergo high deflections in their operation exhibit more load carrying capacity with small spiral angles. Highly optimized, ground bevel gearsets benefit more from the face contact ratio with respect to the load sharing between several teeth. In this case spiral angles between

30° and 35° show optimal results. A larger spiral angle promotes a smooth, rather than an abrupt, tooth engagement and offers more elasticity that results in quieter-running transmissions.

Cutting method. Continuously manufactured bevel gears have a parallel tooth depth; their unrolled flank line is an epicycloid (Fig. 14, top). Continuous cut (face hobbed) bevel gears that are lapped after heat treatment show very good conditions for smooth tooth engagement and quiet operation. Face hobbed flank surfaces feature generating flats that cross the contact lines of the two meshing flanks under an angle. This allows the lapping compound to be present in the contacting zone and to abrasively remove the multitude of contacting points between contact line and generating flats.

Face hobbed bevel gears with a large number of blade groups show a “natural” insensitivity towards load-affected deformations (similar effect as small cutter radii). A simulation of the displacement can help in finding a favorable combination between the number of blade groups and the cutter radius. Face hobbed bevel gearsets can be lapped with very good results, but cannot be ground because of the epicycloid flank form and the slot width taper. Face milled bevel gearsets have their generating flats oriented parallel to the contacting lines between pinion and gear, which causes the lapping compound to be “wiped off” and the lapping effect to be diminished. Lapping of face milled bevel gears often increases the magnitude of the generating flats because the contacting lines slide over each generating flat simultaneously, resulting in high-frequency rolling noise.

Face milled bevel gearsets (Fig. 14, bottom) are therefore not well-suited for lapping, and yet allow application of modern and highly precise grinding methods for their hard finishing (see also original text, chapter 4). This means that the advantages of grinding are only available for bevel and hypoid gears manufactured in a single-indexing process, which explains today’s split of the hard finishing methods (face hobbing → lapping, face milling → grinding).

Face milled bevel gearsets ground after

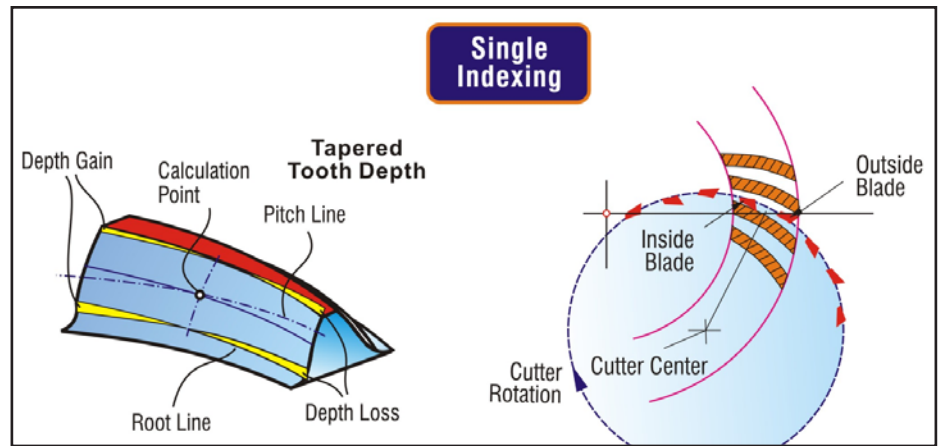

Figure 14 Influence of cutting method.

heat treatment can be finished with non-linear flank modifications that can be adapted to the precise load-affected displacements, and also achieve rolling with minimized mesh impact.

Limitations in Dimension Sheet Data Alterations

The discussed basic gear data offers many possibilities to improve the strength and rolling behavior of bevel gearsets. Yet, in many cases the parameters are given from an existing transmission whose requirements have somewhat changed. An example is a vehicle that received a higher-powered engine, but the dimension of the axle drive unit cannot increase in size. Another example is a suddenly noticed gear noise that must be eliminated or reduced. It might occur because of an alteration in the vehicle components that influence or change the acoustic transmission path.

For strength optimization, new or improved basic gear data are generally required. An exception is the case where the gear basic data are already optimal and the gearset cannot be enlarged, which however features an Ease-Off that has not been optimized with modern flank modifications. In this case, a significant strength increase using suitable flank form optimizations can be achieved. For noise optimizations the alteration of the basic gear data is not possible in 9 of 10 cases because of time and cost restraints. If the basic parameters have been changed, then requalification of the gearset on a test rig and in a vehicle is required. This is true even if the reason for the change was only based on unacceptable noise emission.

Sophisticated flank optimizations generally have a neutral or positive influence on the strength of a gearset. It is widely accepted in the industry that a gearset does not have to be re-qualified for strength after an Ease-Off optimization, as long as the basic gear parameters remained the same. For certain small improvements or changes, the rule that is taught in engineering around the world should be applied, i.e. — Whenever possible, the proven base geometry must be preserved and only gradual changes, in order to achieve the required improvements, should be implemented. This rule is the key to successful products and short developmental times.

Optimization by flank form modifications. Flank form modifications are deviations of a flank pair from their conjugate condition (see also original text chapter 4). Conjugate flank pairs are not practically applicable since the conjugate characteristic will vanish in the presence of loads and component tolerances. Instead, edge contact occurs with unfavorable load concentrations, together with a “saw tooth-shaped motion error.”

Bevel and hypoid gearsets require Ease-Off in profile and length direction, beginning at the tooth center with zero and increasing outwards towards the boundaries of the teeth. Until now circular flank crowning was applied in nearly all cases; Figure 15 shows the three commonly applied elements of crowning design.

Profile crowning is a circular removal of the flank profile, which appears in the presentation plane as Ease-Off, like a section of a cylinder with the axis of the cylinder oriented in the direction of the flank line (Fig. 15, left). Length crowning

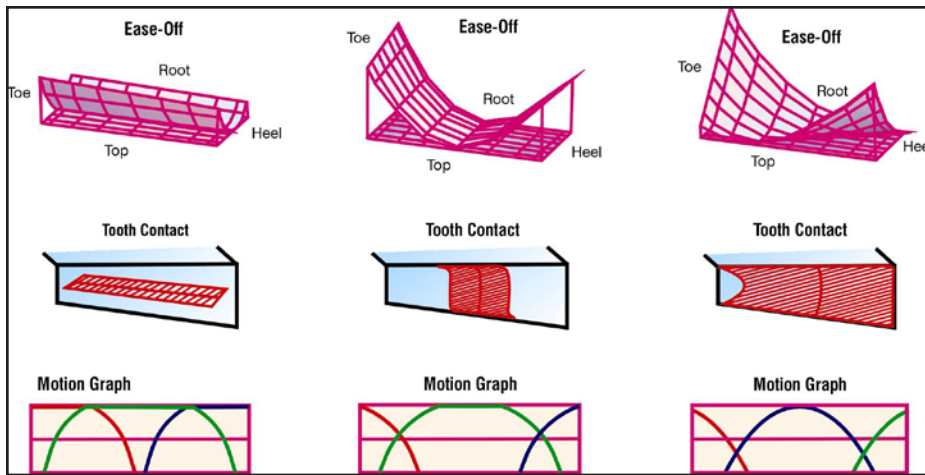

Figure 15 Conventional Ease-Off design elements.

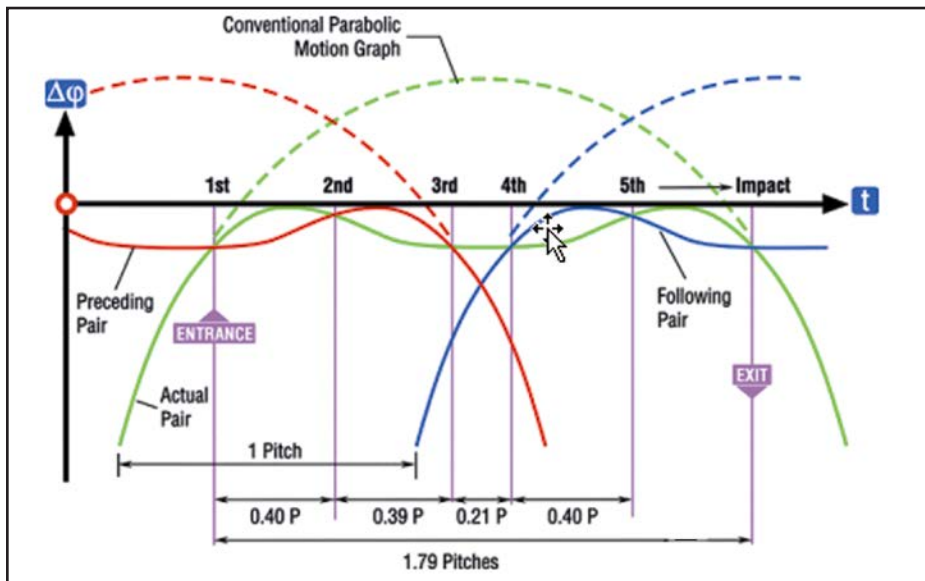

Figure 16 Advanced motion error modifications.

is a circular material removal in flank line direction, which appears in the presentation plane as Ease-Off like a section of a cylinder with the axis of the cylinder oriented in flank line direction (Fig. 15, center). Flank twist is created with a circular material removal that appears in the presentation plane as a section of a cylinder, with the axis of the cylinder oriented in the direction of the contact lines (Fig. 15, right). The figure sequence below the Ease-Off graphics show the tooth contacts and motion errors that result from each particular crowning. When practically applied, bevel and hypoid gears always feature a combination of the three fundamental crowning elements shown in Figure 15.

Today's Gleason bevel and hypoid gear cutting and grinding machines offer the possibility of superimposing higher order motion combinations. These opportuni-

ties are utilized by today's flank correction software — e.g., Gleason *UNICAL*, for achieving flank modulations along the path of contact during the generating process, and which are superimposed onto the traditional corrections of Figure 15 in order to achieve nearly any modification of the Ease-Off. This new strategy for Ease-Off design can be realized with Gleason *UNICAL* and is called “selective crowning.”

Strength Improvement and Noise Reduction with Ease-Off Modification

Flank form modifications may be used as effective tools in order to achieve noise reduction and strength optimization; these modification possibilities are available today on all Gleason cutting and grinding machines. In a typical case the maximum possible contact ratio from the Dimension Sheet is only achieved under

maximal load — and even then the load sharing between adjacent tooth pairs is very unfavorable. With the “right” modification the contact ratio, even under partial load, can be increased. The load sharing of the simultaneously engaged tooth pairs can be arranged so that no tooth pair need be transmitted more than 60% of the torque. 80% or more of the load in traditional bevel and hypoid gear designs is transmitted by single tooth pairs. This indicates that the improvement by certain modern Ease-Off modifications is significant and may result in a 25% increase in root bending strength and a 30% higher surface strength, as compared to gearsets with a standard second order crowning as given in Figure 15.

Higher order modifications can be limited to certain flank sections, thus allowing for adjustment of the correction to meet the different requirements for the entrance and exit zone, as well as the flank center (see also original text chapter 16). Figure 16 shows the graphic for a motion transmission generated with a fourth-order flank modification. The effect of a flat motion graph with a wave shape has no disadvantages. The load sharing between adjacent teeth pairs is more uniform and less abrupt than the diagrams in Figure 15 (Ref. 4). The nominal contact ratio for a conventional Ease-Off is equal to one of the higher order Ease-Offs; yet, the higher order Ease-Off utilizes the potential that the nominal contact ratio presents more “intelligently.”

For gear optimization with higher order flank surface modifications, it must be noted that gearsets that have already been optimized with a modern tool, such as Gleason *UMC*, that the potential for improvement might already be exhausted. The attempt to achieve even more strength increase with more optimization might result in a turn in the opposite direction. Also, the attempt to address certain noise excitations with additional *UMC* optimizations might reduce the strength of the gearset. It is recommended in any case to conduct finite element calculations parallel to the geometric flank form optimizations in order to track changes in the strength characteristics during the improvement process.

Summary

It is important to realize that the basic gear data of the macrogeometry represent the foundation of the physical properties of a gearset. Flank form modifications can contribute to utilizing those properties completely. A conventional Ease-Off does not achieve the entire strength potential of a gearset. An optimized Ease-Off makes it possible to utilize all of the physical possibilities of a gearset by optimally using existing proportions. An optimal combination between gear basic data and flank form modifications can often enable the transmission of twice the torque and, at the same time, be significantly quieter in comparison with a gearset with less-than-optimal design.

Generally, strength optimization requires a new, basic design. An exception is when the basic design is found to be optimal, but the Ease-Off is conventional and shows significant room for improvement. In this case modern flank form modifications can contribute to a great improvement of the load carrying capacity—and might in fact be the only possibility if the existing gear size cannot be increased. Noise optimization requires in most cases only a flank form modifica-

tion. An exception is given if the present design already has a modern flank form optimization. In this case, noise optimization will not be easily accomplished.

If an improvement of the noise characteristic via Ease-Off still seems possible, then a finite element calculation of the situation, before and after the optimization, is recommended. In the case where critical stress conditions are discovered, it might be necessary to optimize the gear basic data first in order to find a new foundation that fulfills the strength requirements, and then as a second step to conduct a modern flank form optimization. The elements making the teeth more elastic (*see original text chapters 6.21, 6.24 and 6.26*) should be considered to assure good load sharing and to guarantee a reduction in noise emission.

The possibility of improving the parameters of a given basic gear design should not be treated as a burden, but welcomed as a seldom-occurring opportunity to improve the roll and strength characteristic of a gearset that has not been brought up to date. Nevertheless, the existing design should be used as a basis since it is possible in most cases to adjust the gearset with a number of

smaller, but significant, improvements to meet today's stringent requirements. One should not make the mistake of believing that the time-consuming practice of gear design can be saved by certain flank optimizations. In short, the last section can be summarized by the following rule: "The basic gear parameters give the direction for the physical properties of a gearset, while modern flank form optimizations only assure a better access to those properties." 

References

1. NN. *Bevel & Hypoid Gear Design*, Gleason Company Publication, Rochester New York, 1956.
2. Stadtfeld, H.J. "Good Basic Design or Sophisticated Flank Optimizations? Each at the Right Time," *Gear Technology*, Jan/Feb 2005, Randall Publishing Inc., Elk Grove Village, Illinois.
3. NN. "Gear Dimension Sheet Explanations," Gleason Company Publication, Rochester, New York, 1982.
4. Stadtfeld, H.J. and U. Gaiser. "The Ultimate Motion Graph — *UMCULTIMA*," Gleason Company Publication, Rochester, New York, August 1999.

For Related Articles Search

bevel gears 

at www.geartechnology.com

Dr. Hermann J. Stadtfeld received in 1978 his B.S. and in 1982 his M.S. degrees in mechanical engineering at the Technical University in Aachen, Germany; upon receiving his Doctorate, he remained as a research scientist at the University's Machine Tool Laboratory. In 1987, he accepted the position of head of engineering and R&D of the Bevel Gear Machine Tool Division of Oerlikon Buehrle AG in Zurich and, in 1992, returned to academia as visiting professor at the Rochester Institute of Technology. Dr. Stadtfeld returned to the commercial workplace in 1994—joining The Gleason Works—also in Rochester—first as director of R&D, and, in 1996, as vice president R&D. During a three-year hiatus (2002–2005) from Gleason, he established a gear research company in Germany while simultaneously accepting a professorship to teach gear technology courses at the University of Ilmenau. Stadtfeld subsequently returned to the Gleason Corporation in 2005, where he currently holds the position of vice president, bevel gear technology and R&D. A prolific author (and frequent contributor to *Gear Technology*), Dr. Stadtfeld has published more than 200 technical papers and 10 books on bevel gear technology; he also controls more than 50 international patents on gear design, gear process, tools and machinery.



Hungry for More?



Everything you need to be a world-class gear manufacturer—the suppliers, the technical information and the market intelligence—can be found online

gear

TECHNOLOGY®

- The GT Library includes a complete archive of back issues and articles, 1984-today
- Directory of suppliers of machine tools, services and tooling
- Product and Industry News updated daily
- Exclusive online content in our e-mail newsletters
- Calendar of upcoming events
- Comprehensive search feature helps you find what you're looking for—fast!

**FREE
SUBSCRIPTIONS**

www.geartechnology.com

Bourn & Koch

ANNOUNCES NEW MANAGEMENT TEAM

Bourn & Koch, Inc. recently announced that Terry V. Derrico has been named president of the company effective October 21st, 2015. Also joining senior management are Kerry Koch (CFO), Greg Champion (vice president of sales and marketing) and Peter Mischler (engineering manager).

Derrico, who was most recently president and CEO of United Grinding North America, brings over 30 years of relevant industry and leadership experience to Bourn & Koch. He has a track record of growing profitable businesses by addressing customer needs and managing complex manufacturing operations. Prior to joining Bourn & Koch, Derrico was a group president within the Industrial Group at The Marmon Group LLC, a division of Berkshire-Hathaway, Inc., and president and CEO of SIG-Pack Inc. He also spent ten years at GE Fanuc as national sales manager, where he built significant growth and developed key markets in North America.

Kerry M. Koch has been appointed chief financial officer, and brings more than 30 years of finance experience. His background includes a heavy concentration in highly-engineered equipment and significant experience in mergers and acquisitions. He was most recently the chief financial officer of Elgin Equipment Group, LLC and previously the interim chief financial officer/corporate controller of Paladin Brands.



Bourn & Koch Management Team, left to right: Greg Champion, vice president of sales and marketing; Kerry Koch, chief financial officer; Peter Mischler, engineering manager; Terry Derrico, president.

Greg Champion has been appointed as the new vice president of sales and marketing at Bourn & Koch. He brings a wealth of sales and marketing experience with him from his tenure with Rockford-based Hennig, Inc., a leader in machine tool protection products. Champion is also the former vice president of sales for Mattison Technologies Co. Bourn & Koch, Inc. is the OEM for Mattison and continues to produce Mattison machine tool products, replacement parts, machine rebuild and repair services. His knowledge of the machine tool industry will be invaluable as Bourn & Koch grows.

Peter Mischler joins Bourn & Koch as the new engineering manager. Mischler was previously the development engineering manager at Fives-Cincinnati and also worked for Ingersoll Machine Tool. Mischler's engineering background and drive

to innovate allows Bourn & Koch to continue their tradition of producing enhanced machine tool designs and products within the metal-working industry. Mischler holds eight U.S. patents created for machine tool applications.

Derrico is excited to work with this talented and experienced management team that has set the objectives to grow the company's key products and segments while expanding Bourn & Koch core competence to the global manufacturing market.

AGMA

NAMES CROSON PRESIDENT

AGMA has named **Matthew E. Croson** as its next president. Croson has more than two decades of leadership and communications experience in manufacturing trade associations and most recently served as president and CEO of the Adhesive and Sealant Council. He will replace Joe T. Franklin, Jr., who is retiring in June after leading AGMA for 25 years.

AGMA was founded in 1916 by 19 manufacturers with a goal of helping improve the emerging gear market by developing technical standardization. Franklin stated, "Under Matthew Croson's leadership, the association will continue that same mission, helping nearly 500 members compete more effectively in today's global marketplace."

Prior to leading the Adhesive and Sealant Council, Croson held communications leadership positions at the Packaging Machinery Manufacturers Institute. He also worked at IntelliData Technologies Corp. and Burson-Marsteller, where he specialized in relationship management and corporate communications.

"Matthew Croson's communications background and his experience bringing individuals, manufacturers and customers together will help AGMA meet the diverse needs of our members," said Dean Burrows, chairman of the AGMA board of directors. "We are confident he will lead the organization's wide range of high-quality programs and services, and will continue to grow membership and participation."

"I'm honored to help AGMA continue to grow and support its members and the gear industry as a whole," said Croson. "I will be working closely with Joe Franklin and the team in the coming months to ensure that the transition of leadership is as seamless as possible."

Croson is an elected member of the board of directors at the National Association of Manufacturers' Council of Manufacturing Associations and is a member of the American Society of Association Executives and the U.S. Chamber of Commerce. He has a bachelor's degree in English from George Mason University in Fairfax, Virginia.

The Search for AGMA's new president was conducted by Association Strategies, Inc., a nonprofit and association executive search firm, located in Alexandria, Virginia.



LMC Workholding

CELEBRATES 100TH ANNIVERSARY

LMC Workholding is celebrating its 100th anniversary in 2016, having provided quality products, services and solutions to the workholding industry for a century. LMC Workholding is the present entity of the Logansport Machine Company, which from 1916 to the present has built a reputation for engineering and manufacturing power chucks, cylinders and special workholding products in Logansport, Indiana.

Though its headquarters and manufacturing facility are located in the Midwest, LMC offers international workholding and machine tool accessory solutions with global partnerships with Chandox in Taiwan, Richter and Stiefelmayer in Germany, Tecnologie FRB in Italy and Atling in Sweden, as well as four offices and service centers in China. The company's latest partnership was in 2013 with Numtec and Makra, two divisions of Alpine Metal Tech GmbH. This new partnership allows LMC to offer quality aluminum wheel machining solutions, including wheel testing, marking, and production equipment.

LMC has also completed \$4 million in expansions over the last three years. In 2013, the company completed a large expansion at its Logansport facility with all green lighting, office renovations and other plant improvements. Several new machines were also added, including an expandable six-pallet horizontal machining center, several vertical machining centers, lathes and grinders. These machines improved LMC's existing capabilities and were used to meet growing demands for products and services, such as larger products and specialty products.



In 2015, LMC added a new automated turning cell to its list of production equipment as part of its continuing expansion. The Mazak MY350 and Fanuc Automation R2000-265kg turning cell and robot load parts weighing up to 350 lbs. into the CNC lathe for machining, removes the parts and places completed parts back on the loading pallet, a job previously done manually. The automated turning cell allows one operator to run up to four lathes with the help of the robot.

A recent \$2 million dollar project allowed the company to add two more machines. A DMG MORI NLX1500 machine now allows LMC to make hydraulic cylinder lock checks in-

GEAR CUTTING TOOLS

MADE IN SWITZERLAND

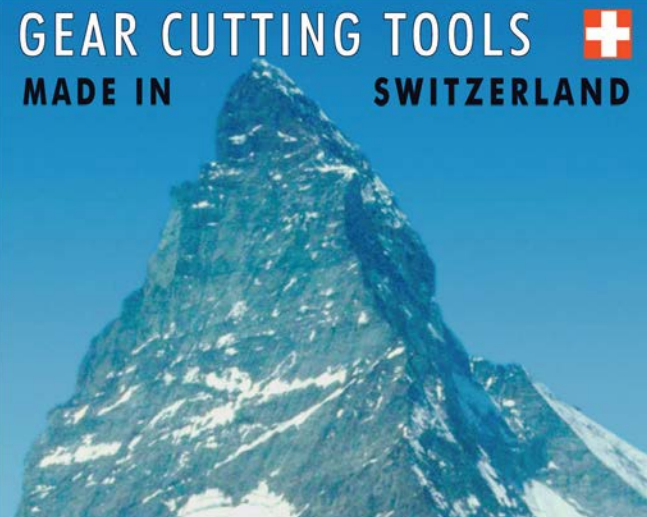

SCHNYDER

US Distributor
HANIK CORPORATION
PHONE 630-986-4800
FAX 630-986-4804
www.hanikcorp.com
email: info@hanikcorp.com

GEAR CUTTING SOLUTIONS
60 YEARS OF TOP TECHNOLOGY

ph: 011-41-32-344-0400 • fax: 011-41-32-344-0404 • www.schnyder.com • mail@schnyder.com



Kean TRANSMISSION

*Connecting to the world
Gear up for the future*



www.keanchina.com

Situated in Jiangyin City of Jiangsu Province, China, Jiangyin Ke'an Transmission Machinery Co., Ltd. is a dedicated manufacturer of high-precision bevel gear and machinery parts with 17 years' experience. The company possesses 8 units of US Gleason bevel gear grinding machine, gear milling machine, heat treatment instrument and over 80 units of other auxiliary equipment. With gear processing module ranging from 2 to 30 and gear grinding diameter of 30-980mm, the maximal precision is up to US AGMA13. The company has been US ABS, French BV and CCS - certified.

Motivated by the business philosophy of 'Our professionalism produces high-quality Integrity paves the way to a success', we devote ourselves to the World transmission machinery industry by substantially satisfying customers' need.



Jiangyin Ke'an Transmission Machinery Co., Ltd.
ADD: No.8 Huangtai Road, Yunting Industrial Park, Jiangyin, Jiangsu Province, China
TEL: 0510-8615 1187, 8601 3998 Fax: 0510-8601 2666 Email: ka@keancn.com

house and a DMG MORI FD125 machine has streamlined its manufacturing process.

“We’ve been the name to know in workholding since 1916 and we’re expanding and growing to continue to meet the demand of our customers and the industry. We’re proud to have made it to 100 years in business and we’re looking forward to serving our customers for many more years,” said Jay Duerr, LMC workholding president and CEO.

LMC’s workholding product line includes high quality chucks and cylinders along with special workholding devices, including aluminum wheel manufacturing equipment, high volume machining power chucks and fixtures, standard and special hydraulic steady rests, special application and large cast type manual steady rests. LMC also offers a line of patented face drivers and centers.

Federal Broach

ANNOUNCES NEW COATING FACILITY AND CAPABILITIES

Federal Broach has completed installation of a new state-of-the-art coating facility. Federal Broach supplies full gear cutting tool services in addition to the existing broach tool and broach machine lineup. In addition to sharpening and recoating all brands of hobs, shaper cutters and broaches and sharpening shaving cutters, Federal Broach sells and supports Mitsubishi gear cutting tools.



According to Joe Witer, president, “The addition of the coating facility extends our capabilities in the gear tool market. We’ve always been known for high quality broach tools and machines, with helical internal gear broaching as a specialty. We now sell and service all gear cutting tools: hobs, shaper cutters, shaving cutters and broaches in our Michigan facility.”

A wholly owned subsidiary of Mitsubishi Heavy Industries America, Inc., Federal Broach applies highly developed coatings for gear tools in the new facility. In addition to titanium nitride (TiN) coating, Federal Broach uses Nano-Dynamic coating for maximum broach tool life. Mitsubishi’s SuperDry III coating for hobs, and a special coating for shaper cutters is also applied and has been proven in both wet and dry cutting applications worldwide.

Rollomatic Inc.

APPOINTS TEAM LEADER OF APPLICATIONS AND SERVICES



Rollomatic Inc., a subsidiary of Rollomatic Holding Switzerland, has announced the appointment of **Daniel Franklin** as the new service/applications team leader at their North American head office in Mundelein, IL.

Daniel Franklin started his career at the Rollomatic factory in Switzerland in 1999. He relocated with his wife and three children to the United States in 2014 and has been an effective and industrious applications engineer at Rollomatic USA in Mundelein. He will take over the team leader’s position with immediate effect. His predecessor, Mac MacKenna, transitioned into a sales manager position in the Northeast. Franklin’s responsibilities will include leading a team of 10 applications and field service engineers, and he will be accountable for all activities relating to test grinding, applications R&D and machine installation, as well as all aspects of field and in-house machine service.

Franklin was born in the U.K. and relocated with his parents to the French-speaking part of Switzerland in his early years. He initially worked in the machine assembly at the Swiss factory. He was soon promoted into the position of applications engineer due to his innate ability to learn new skills. Franklin was highly regarded as a quick-learner and diligent worker, and rose to be one of Rollomatic’s senior applications engineers.

After relocating to the United States, Franklin was a senior applications engineer in Mundelein, IL. During his extensive travels in North America, he became familiar with the techniques and methods that are prevalent in U.S. manufacturing. His widespread experience in the cutting tool field and CNC grinding machines made him an ideal candidate for this position. His support-oriented customer approach and his strategic mindset will benefit the team and enhance the effectiveness of Rollomatic in the competitive field of selling high-end CNC grinding machines.

“Daniel’s impressive track record working for Rollomatic and his ability to communicate and relate to people make him the ideal leader. Such qualities are key to expanding the brand name and drive the ever-evolving new technologies of the company. We fully expect that his talents will support the profitable growth of our business”, said Eric Schwarzenbach, president of Rollomatic Inc.

William Jandeska

RECOGNIZED FOR LIFETIME
ACHIEVEMENTS IN POWDER METALLURGY

William F. Jandeska, Jr.,

FAPMI, president, Midwest Metallurgical, Ltd., and project manager for the Center for Powder Metallurgy Technology, has been selected to receive the Kempton H. Roll PM Lifetime Achievement Award by the Metal Powder Industries Federation. The award will be presented during the Industry Luncheon on Monday, June 6, during Powdermet 2016—the International Conference on Powder Metallurgy & Particulate Materials in Boston, Massachusetts, June 5–7, 2016.



Jandeska has distinguished himself as an expert in the field of powder metallurgy (PM) through developing innovative components and relationships between suppliers and vendors. He has promoted the continued growth of PM for more than 44 years through the joint involvement of part fabricators and the end-user community, which is evident by his support and leadership activity in MPIF, APMI, SAE, and ASM.

Beginning his career as an intern at U.S. Steel and Caterpillar Tractor, Jandeska worked while completing his BS, MS, and Ph.D. from the University of Illinois. After completing his degrees in 1971, Jandeska joined General Motors Research Labs for a 20-year tenure, which included an appointment to assist the DoD National Technology Leader for GM with responsibility for high-performance magnetics, P/F connecting rods, main bearing caps, and development of advanced gearing materials. In 1991, he joined GM Global Powertrain Group as manager for PM technology and lead subject matter expert for the PM creativity team, positions he held until his retirement in 2006.

Jandeska has received numerous awards, including the MPIF Distinguished Service to Powder Metallurgy Award and the MPIF Automotive Achievement Award. He also co-chaired both the 1989 Powder Metallurgy Conference & Exhibition and the 2002 World Congress on Powder Metallurgy & Particulate Materials, in addition to chairing the MPIF Technical Board from 1989 to 2003. Jandeska has conducted APMI International chapter presentations on technology, needs, and the direction of the automotive industry; authored numerous technical papers and presentations at MPIF/APMI annual conferences; and has held numerous seminars educating hundreds of GM personnel worldwide. Jandeska is an APMI International Fellow, ASM International Fellow, and received the SAE McFarland Award and the ASM Outstanding Young Member Award.

The Lifetime Achievement Award, named in honor of Kempton H. Roll, founding executive director of MPIF, was established in 2007 in order to recognize individuals with outstanding accomplishments and achievements who have devoted their careers and a lifetime of involvement in the field of PM and related technologies. This will only be the third time the award has been given since its inception.

BEYTA GEAR SERVICE 

**PUTTING
A LIFETIME
OF
GEAR
DESIGN
EXPERIENCE
TO WORK FOR YOU**

- Reverse engineering
- Gearbox upgrades
- Custom gearbox design
- Specification development
- Project management
- Vendor qualification
- Design reviews
- Bid evaluations
- Tooling design
- Customized gear training
- Equipment evaluation
- Custom machine design

Charles D. Schultz
chuck@beytagear.com
[630] 209-1652

www.beytagear.com

**Unlocking
the Vault**

We've optimized almost 30 years of gear manufacturing articles with our enhanced search engine at

www.geartechnology.com

www.geartechnology.com/issues/

gear
TECHNOLOGY

May 12–14—2016 AGMA & ABMA Annual Meeting

Omni Amelia Island Plantation Resort, Amelia Island, Florida. Highlights for the 2016 AGMA & ABMA Annual Meeting include a diverse lineup of speakers and presenters, the return of the popular AGMA/ABMA golf tournament (a scramble at the Amelia Island Omni Ocean Links Golf Course that winds along the coastal Atlantic Ocean), a formal Centennial Dinner, First Timer's Luncheon and special AGMA and ABMA dinners for its members. The whole meeting community will group together for a historic photo on Thursday afternoon. Additionally, retired members are welcome back to the meeting, so please contact the AGMA or ABMA if you know any fully retired gear or bearing executives that need an invitation. Resort service fee includes complimentary self-parking, unlimited deluxe internet access, on-property resort transportation services, unlimited use of health and fitness center, in-room coffee service, local and toll free phone access and resort beach access. For more information, visit www.agma.org.

May 17–19—Wall Colmonoy Modern Furnace Brazing School

Cincinnati, Ohio. For over 60 years, Wall Colmonoy engineers have gained practical experience on actual problems in brazing plants around the world. Knowledge and practical application will be taught by the company's industry-leading brazing experts. The Modern Furnace Brazing School will allow attendees to apply workable solutions to their brazing needs. Topics include: brazing technology, definitions, overview and joint design, diffusion mechanism and metallurgical reactions between base and filler metal, overview of brazing atmosphere, evaluation and quality control of atmosphere, types of furnaces, heating methods and furnace controls, a detailed look at various nickel-based braze filler metals, brazing aids and their use and application, reviews of fundamental pre- and after-brazing cleaning, assembly, fixture, brazing cycles, and other brazing processes, inspection methods and process controls, and actual applications and case studies. The school will also provide practical experience on the shop floor for: pre-cleaning, blasting, selecting fixture, setting the furnace cycle, examining the brazed parts, filler metal application methods, screen printing/stencil, MicroSpray System, roller coating, powder, paste dispensing systems, and transfer tape. For more information, visit www.wall-colmonoy.com.

May 17–19—Advanced Gear Design and Theory

University of Wisconsin-Milwaukee, School of Continuing Education. Explore manufacturing methods and considerations, inspection and quality control, materials and heat treatment, drawing data requirements, specifications, basics of load capacity rating and lubrication types and methods. With a strong emphasis on the proper selection, design application and use, rather than fabrication, designers, users and beginning gear technologists can all benefit from the curriculum. The class is taught by Raymond Drago, chief engineer for Drive Systems Technology, Inc. For more information, visit <http://uwm.edu/sce/courses/advanced-gear-design-and-theory>.

May 23–26—Windpower 2016

New Orleans, Louisiana. This exhibition brings together innovators, thought leaders and policy makers to chart wind energy's course for the future. Technical sessions include "Wind 201: Wind Development for Pros," "U.S. Offshore Wind Energy," "U.S. Wind Energy Market Forecasts," "Slipping Down the Cost Curve," "Advances and Innovations in Interconnection Strategies for Wind Farms" and more. More than 100 presentations and sessions are categorized into five main groups including power station, tech station,

operations station, project development station and thought leader theater. Keynote Speaker Steve Farber, author of "The Radical Leap," will share thought-provoking and practical leadership techniques and tips. Whatever the audience, his voice is always humorous, poignant and original. No matter what is challenging an organization—improving customer service, coping with change, inspiring transformation, improving corporate culture, recruiting and retaining great talent, building teamwork, fostering innovation—it all comes down to leadership. For more information, visit www.windpowerexpo.org.

June 5–8—Powdermet 2016 Boston, MA. Powdermet will be coming to Boston in conjunction with Additive Manufacturing with Powder Metallurgy. The technical program will feature over 200 worldwide industry experts presenting the latest in powder metallurgy, particulate materials and metal additive manufacturing. A keynote presentation will be delivered by Jim Carroll, world-renowned author, futurist and trends and innovation expert, who will address delegates on the new face of modern manufacturing. Over 100 companies representing leading suppliers of powder metallurgy and particulate materials processing equipment, powders and metal additive manufacturing will attend the trade exhibition. Other special conference events include special guest speakers, luncheons, Sunday evening's welcome event, and Tuesday evening's dinner at the John F. Kennedy Presidential Library & Museum. For more information, visit www.mpif.org.

June 7–9—Ipsen 2016 U Classes Northern Illinois University at Rockford. These three-day courses provide attendees with a broad overview of furnace equipment, processes and maintenance, as well as a hands-on approach to learning while receiving qualified tips directly from the experts. Throughout the course, attendees are able to learn about an extensive range of topics - from an introduction to vacuum and atmosphere furnaces to heat treating, furnace controls, subsystems, maintenance and more. They will also be able to view the different furnace components firsthand while learning how they affect other parts of the furnace and/or specific processes, take part in one-on-one discussions with Ipsen experts, participate in a leak detection demonstration and tour Ipsen's facility. Overall, Ipsen U allows participants to build and refresh their knowledge of heat-treating equipment and processes through applied learning. Regardless of where you fall on the expertise scale - maintenance, operator, engineer, project manager and/or plant manager - Ipsen U's instructors will provide the necessary level of information in a casual open-forum environment. For more information, visit www.ipsenusa.com/ipsenU

June 27–29—Made by Klingelberg Gear Seminar Series and WZL Gear Conference

Ann Arbor, Michigan. The Klingelberg Gear Seminar will keep customers abreast of current technologies and innovations in bevel gear, cylindrical and gear measuring technology. Presenters will include the head of the respective specialist departments at Klingelberg. Evening meals will provide opportunities for discussions and exchanges in a relaxed atmosphere. In addition, Klingelberg will host the 6th WZL Gear Conference on June 28, 2016. The Laboratory for Machine Tools and Production Engineering (WZL) at RWTH Aachen University will present the latest research results and developments in the gear industry. The Gear Seminar Series is free and the WZL Gear Conference is \$260 per participant. For more information, visit www.getriebekreis.de.

gear

TECHNOLOGY

FREE SUBSCRIPTION

Gear Technology, is the world's leading publication on gear design, engineering and manufacturing. To sign up or renew your **FREE SUBSCRIPTION** use the form below.



FIND THE EXACT SUBJECTS YOU ARE LOOKING FOR: Subscribers now get access to the 30 years of searchable articles in our online archive.

1 **YES** I want to receive/continue to receive **Gear Technology FREE!**
 No thank you.

Name: _____ (print) Job Title/Position: _____
Signature _____ (required) Date: _____

2 → E-mail _____
(So we can notify you when the online edition is available)

3 → Please update your contact information or attach you business card here. (No Staples)

Company Name: _____
Address: _____

City: _____
State/Province: _____ ZIP+4/Postal Code: _____
Country: _____
Telephone: _____ Fax: _____
E-mail: _____
Website: _____

4 → What is your primary **JOB FUNCTION** (check **ONLY** one)

<input type="checkbox"/> Corporate Executive (B)	<input type="checkbox"/> Purchasing (L)
<input type="checkbox"/> Manufacturing Production Management (C)	<input type="checkbox"/> Marketing, Sales or Communications (M)
<input type="checkbox"/> Manufacturing Production Department (D)	<input type="checkbox"/> Quality Control Management (P)
<input type="checkbox"/> Manufacturing Engineering Management (E)	<input type="checkbox"/> Quality Control Department (Q)
<input type="checkbox"/> Manufacturing Engineering Department (F)	<input type="checkbox"/> Other (Please describe) (N) _____
<input type="checkbox"/> Product Design, R&D Management (H)	
<input type="checkbox"/> Product Design, R&D Department (I)	

5 → My company's principal product or service is: _____

6 → How are YOU involved with gears (check all that apply)?

- My company **MAKES** gears (20)
- My company **BUYS** gears (22)
- I **DESIGN** gears (23)
- I am a **SUPPLIER** to the GEAR INDUSTRY (please specify product or service) (24)

Is there a colleague within your company that might benefit from having their own copy of **Gear Technology** magazine?

Name: _____
Title: _____

DIGITAL SUBSCRIPTIONS

- YES**, I want to be notified each issue when **Gear Technology** is available online
- YES**, I would like to receive **Gear Technology's** monthly e-mail newsletter
- YES**, I would like to receive **Gear Technology's** twice monthly e-mail Product Alerts
- YES**, I would like to receive 3rd-party e-mails from **Gear Technology's** advertisers and partners
- YES**, I would like to receive subscription renewal notices by e-mail
- No**, I do not wish to be contacted by e-mail.

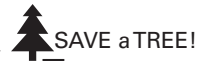

I **ONLY** want the digital edition (e-mail required)

All Metals and Forge — Page 10
steelforge.com

B&R Machine and Gear Corp. — Page 17
www.brgear.com

Beyta Gear Service — Page 67
www.beytagear.com

The Broach Masters & Universal Gear — Page 19
www.broachmasters.com

Circle Gear — Page 32
www.circlegear.com

DK Surface Hardening — Page 34
www.dksurfacehardening.com

DTR Corp. — Page 22
www.dragon.co.kr

Excel Gear — Page 41
www.excelgear.com

Foerster Instruments, Inc. — Page 33
www.foerstergroup.de

Forest City Gear — Page 7
www.forestcitygear.com

German Machine Tools of America — Page 11
www.gmtamerica.com

Gleason Corporation — Pages 36-37
www.gleason.com

Hanik Corp. — Page 65
www.hanikcorp.com

Hannover Fairs USA — Page 71
www.industrialtechnology.events

Hans-Juergen Geiger Maschinen-Vertrieb GmbH — Page 43
www.geiger-germany.com

Hobsource Inc. — Page 35
www.hobsource.com

IMTS — Page 13
www.imts.com

Innovative Rack & Gear — Page 33
www.gearacks.com

Ipsen International — Inside Back Cover
www.ipsenusa.com

JiangYin Kean Transmission Machinery — Page 65
www.keancn.com

Kapp Technologies — Pages 3, 33
www.kapp-usa.com

KissSoft USA, LLC — Page 4
www.kisssoft.com

Klingelberg — Outside Back Cover
www.klingelberg.com

Koepfer America LLC — Page 32
koepferamerica.com

Koro Sharpening Service — Page 32
www.koroind.com

Liebherr — Page 5
www.liebherr.us

Luren Precision — Page 15
www.lurenusa.com

McInnes Rolled Rings — Page 29
www.mcinnesrolledrings.com

Micro Surface Corp. — Page 32
www.ws2coating.com

Midwest Gear & Tool — Page 4
midwestgear@sbcglobal.net

Midwest Thermal-Vac — Page 34
www.mtvac.com

Mitsubishi Heavy Industries America — Page 8
www.mitsubishigearcenter.com

Mitsubishi Materials — Page 21
www.mmus.com

Nordex Inc. — Pages 16, 33
www.nordex.com

Oelheld U.S. Inc. — Page 35
www.oelheld.com

Penta Gear Products — Page 39
www.gearinspection.com

Perry Technology Corp. — Page 35
www.perrytechnology.com

Presrite Corp. — Page 34
www.presrite.com

Proto Manufacturing — Page 23
www.protoxrd.com

Rave Gears & Machining — Page 27
www.ravegears.com

Schnyder S.A. — Page 65
www.schnyder.com

Star SU LLC — IFC-Page 1, Page 32
www.star-su.com

GLEASON TOOLING

CHANGE GEARS for Models 2, 2A, 7A, 12, 12B, 14, 16, 102, 104, 106, 108, 114, 116, 118, 24, 24A, 26, 28, 606, 607, 641, 645, 650

INDEX PLATES, LIFT/DROP CAMS and **GENEVAS** for Models 605, 606, 607, 608, 609, 610

PRECISION INDEX PLATES for Models 19, 29 and 120 **CURVIC COUPLING GRINDERS**

LIFT/DROP CAMS for Models 109 and 112

CAMS for Models 645, 41T & 44T **GENERATING** and **FEED CAMS** for Models 2, 2A, 102

DRESSER CAMS for Models 17, 19, 120, 463

CUTTER BODIES for Models 104 and 114 Coniflex Straight Bevel

CUTTER BODIES 3.50", 6" & 9" **HARDAC & HARDAC III**

QUENCH PRESS UNIVERSAL LOWER DIE SETS, 15" diameter, 10 rings **GAUGE SET** for Model 24A

ALIGNMENT GAUGES, #14/#14, #14 short/#39 short, #14 Long/#39 Long, #39/#39, all with Collars & Blocks

CUTTER BLADES for Model 104 **PLANER FORMER** for Models 54 & 154

Wheel Mounts for Grinders J27U **Dresser Blocks** for 32 degree, 40 degree, & 45 degree

Dresser Arms J17U & J19C **Variable Stop Cams** J17U **Chucking Arbors**



www.gearmachineryexchange.com

Motion, Drive & Automation

North America

September 12–17, 2016

McCormick Place
Chicago, IL

www.industrialtechnology.events

Trade fair for motion control, power
transmission and fluid technology

Register
now!

CO-LOCATED WITH



POWERED BY

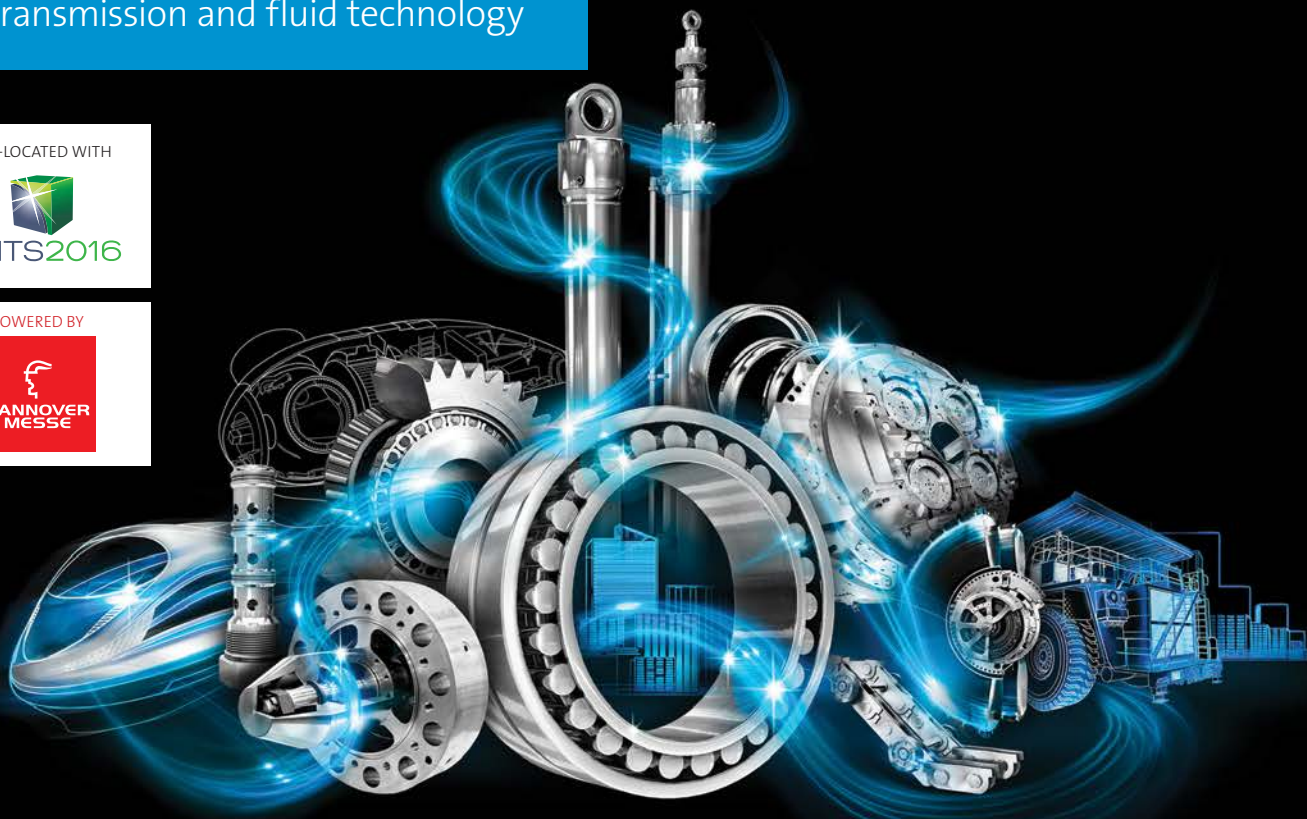

Deutsche Messe

MDA
NORTH AMERICA

NOME Is Where The Energy Is

Jack McGuinn, Senior Editor

According to the U.K.-based WITT Energy website (*witt-energy.com*), **“The WITT is the only device in the world that can capture energy from all movement and turn it into electricity. No other energy system can exploit the full spectrum of movement, enabling it to harvest power from water (sea, river or tidal), wind and human or animal motion.”**

It continues...

“Motional energy is all around us—on land, sea and in the air. And now there is a technology that can capture this motion and convert it into usable electrical power. We have global companies working with us to bring out first product—the Marine WITT—into production, and many customers wanting product.”

Make that natural occurring motional energy—NOME—to be precise.

We saw that Gibbs Gears (*gibbsgears.com*), another British outfit, was entrusted with the gearbox design-and-build for the WITT. Intrigued by the project and its potential, we sent Gibbs a few questions. They were quickly and completely answered by Dave Worthington (IEEng MIET), Gibbs Gear operations director.

How involved was the design process for this gearbox? What, if any, unique challenges were there to overcome? Can you share the specs with us?

“Martin Wickett, chief technical officer and co-founder, is a senior civil engineer who designed and built the original WITT prototypes, and holds the design patents for the mechanism.

“Gibbs Gears reviewed the original designs and, working with Martin, have designed a larger unit working to the design specifications. All of the original prototype units were built using ‘stock gears.’ Gibbs Gears have optimized the gear design for the most efficient arrangement.

“The Wave Energy Converter (WEC) we are currently manufacturing is designed to be contained within a sealed spherical buoy that will be anchored to the sea bed. Independently acting pendulums drive the transmission system—three modular gearboxes, converting all motion, in any combination of the six degrees of freedom, into a single unidirectional rotation of a flywheel, to produce electricity. The WITT unit harvests chaotic motion—fast, slow or erratic—turning it into useable power.

“The WITT WEC has two 50kg weights at the end of 0.5m pendulums. Each pendulum is connected to a gear box assembly that convert the motion of the swinging pendulum into a unidirectional rotation. The assembly is mounted on a central axis which can also rotate about its own axis. The output shaft is connected to an alternator via an electronic control panel that monitors the speed and power in order to harvest the energy generated.”

Did Gibbs have to bid on the contract or did you “earn it” via reputation?

“Gibbs Gears met with founders Martin and Mairi Wickett when they were looking for a suitable partner for the next stage in the development of their product. It was a case of being in the right place at the right time initially, but it was our reputation and personality that led to the decision to choose to work



The WITT wave energy converter (WEC) gearbox supplied by Gibbs Gears. (Illustration courtesy Gibbs Gears.)

with Gibbs Gears. We were happy to have Martin

become part of the design team, so rather than working in isolation and submitting a final product, Martin and Mairi have been involved in every step of the design—a true working partnership. Our track record of delivering prototype development design-and-build projects was also a key factor in their decision. In particular WheelTug, where Gibbs Gears designed and built the gearboxes in conjunction with an international, multi-disciplined team for the M1 ground tests that were undertaken in Prague, June 2012. The WheelTug e-taxi system is a nose-wheel-mounted motor- and-drive unit powered by the aircraft’s APU.”

I noticed this gearbox referred to as a “one-off.” So it cannot be adapted for a different application?

“The WEC unit we are currently building is a one-off prototype development unit. A series of tank tests will be undertaken once we have delivered the unit at the end of June, and from the data recorded there may be some changes required to the final design of the product. The design concept can, however, be scaled. Larger and smaller designs are currently being investigated.”

Witt chairman Admiral Sir James Burnell-Nugent described the technology as “the most exciting development in renewable energy since the solar panel.”

The WEC currently being manufactured is the soul of the machine. It is designed to be contained within a sealed spherical buoy that will be anchored to the sea bed. Independently acting pendulums drive the transmission system—three modular gearboxes—converting all motion, in any combination of the six degrees of freedom, into a single, unidirectional rotation of a flywheel, to produce electricity. The WITT unit harvests chaotic motion, fast, slow or erratic, turning it into useable power.

This is serious stuff. The firm’s Crowdfunding bid was wildly successful, recently announcing that they had reached in April their stated goal of £2 million (\$2,855,600 U.S.) in very short order.

And if they are looking for other scaled-down applications beyond capturing wave and wind movement, I’ve got just the ticket—an array of WECs situated within both chambers of the U.S. Congress. The lip-flapping-captured energy conversion possibilities are practically limitless. ⚙️

ATLAS

Walkaround Video

Ipsen's ATLAS atmosphere furnace heat treatment line, which is manufactured and serviced in the USA, combines the achievements of past atmosphere furnaces with the evolutionary innovations of the future. Receive a close-up look at the features, benefits and technological advantages of this single-chain, batch atmosphere furnace with Ipsen's ATLAS walkaround video.

View the inner-workings and many features of the ATLAS, including:

- Load size of 36" x 48" x 38" (W x L x H)
- Improved functionality and precision of the quenching system – TurboQuench™
- Intelligent controls with predictive process capabilities – Carb-o-Prof®

Call Our Sales Team

1-800-727-7625

International: +1-815-332-2545

Ask for Mike, ext. 2545

TIPS of the Trade

Producing high-quality parts in an atmosphere furnace is about more than using the latest advancements in technology and equipment; it also involves enhancing the carburizing and quenching processes. To start, when carburizing and quenching parts, it is essential to achieve uniformity of temperature and gassing, optimize flow and aim for ...



Scan the QR code to watch the video and read the full technical article, or visit bit.ly/ATLAS-technical-resources



HIT THE MARK.



MAXIMUM ACCURACY SOLUTIONS
FOR BEVEL GEAR MANUFACTURERS
BY KLINGELBERG



All over the world gear manufacturers highly appreciate Klingelberg solutions. With an Oerlikon spiral bevel gear cutting machine C 50 for gears up to 500 mm in diameter you "draw the bow" like no one else. Combined with a Klingelberg P 65 measuring center, which totally fits to the Oerlikon cutting machine C 50 due to interacting software components, you "hit the mark" with the highest precision.

Take your advantages in gear manufacturing with the accuracy of Klingelberg solutions.

Hit The Mark:
www.klingelberg.com
www.hofler.com

KLINGELBERG America, Inc.
p. +1 734 470 6278
e. usa.sales@klingelberg.com

NEXT EVENTS:



CONTROL
April 26-29, 2016
Hall 1 Booth 1418
Stuttgart, Germany



METALLOBRABOTKA
May 23-27, 2016
Booth 82A16
Moscow, Russia

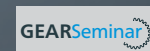

KLINGELBERG
GEAR SEMINAR*
June 27 and 29, 2016
Ann Arbor, Mi, USA



WZL GEAR CONFERENCE*
June 28, 2016
Ann Arbor, Mi, USA

*Exclusive event, number of attendees is limited

OERLIKON

BEVEL GEAR TECHNOLOGY

HÖFLER

CYLINDRICAL GEAR TECHNOLOGY

KLINGELBERG

MEASURING TECHNOLOGY

KLINGELBERG

DRIVE TECHNOLOGY