

# On the Correlation of Specific Film Thickness and Gear Pitting Life

Timothy L. Krantz

The effect of the lubrication regime on gear performance has been recognized, qualitatively, for decades. Often the lubrication regime is characterized by the specific film thickness defined as the ratio of lubricant film thickness to the composite surface roughness. It can be difficult to combine results of studies to create a cohesive and comprehensive data set. In this work gear surface fatigue lives for a wide range of specific film values were studied using tests done with common rigs, speeds, lubricant temperatures, and test procedures. This study includes previously reported data, results of an additional 50 tests, and detailed information from lab notes and tested gears. The data set comprised 258 tests covering specific film values (0.47-5.2). The experimentally determined surface fatigue lives, quantified as 10-percent life estimates, ranged from 8.7-86.8 million cycles. The trend is one of increasing life for increasing specific film. The trend is nonlinear. The observed trends were found to be in good agreement with data and recommended practice for gears and bearings. The results obtained will perhaps allow for the specific film parameter to be used with more confidence and precision to assess gear surface fatigue for purpose of design, rating, and technology development.

## Introduction

The power density of a gearbox is an important consideration for many applications and is especially important for gearboxes used on aircraft. One factor that limits gearbox power density is the ability of the gear teeth to transmit power for the required number of cycles without pitting or spalling. Methods for improving surface fatigue lives of gears are therefore highly desirable.

Gear and bearing performance is strongly influenced by the lubrication condition and the topography of the contacting surfaces. Research to understand and optimize the performance of systems using gears and bearings has a long history, and studies continue today to refine the qualitative understanding and quantitative relationships. The lubrication condition and surface topography have a strong influence on all of friction, scoring and scuffing, wear, micropitting, and surface fatigue of gears and bearings.

The effect of oil viscosity and surface finish on the scoring load capacity of gears was investigated experimentally more than 50 years ago (Ref. 1). Patching (Ref. 2) evaluated the scuffing properties of ground and superfinished surfaces using turbine engine oil as the lubricant. The evaluation was performed using case-carburized steel discs. The discs were finish ground in the axial direc-

tion to orient the lay perpendicular to the direction of rolling and sliding, thereby simulating the conditions normally found in gears. Some of the discs were superfinished to provide smoother surfaces. The Ra of the ground discs was about 0.4  $\mu\text{m}$  (16  $\mu\text{in}$ ), and the Ra of the superfinished discs was less than 0.1  $\mu\text{m}$  (4  $\mu\text{in}$ ). They found that compared with the ground discs, the superfinished discs had a significantly higher scuffing load capacity when lubricated with turbine engine oil and subjected to high rolling and sliding speeds. They also noted that under these operating conditions, the sliding friction of the superfinished surfaces was the order of half that for the ground surfaces. Others have reported similar trends while producing more refined understanding of the relationships of surface texture and operating conditions to gear scoring and scuffing (Refs. 3-6).

The influences of lubricant viscosity and additives on gear wear were evaluated by Krantz and Kahraman (Ref. 7). Gears tested to study surface fatigue were evaluated to quantify gear wear rates as influenced by lubricant viscosity and additives. The gears of that study were case-carburized and ground finished. The wear rates when gears were lubricated by a nine-centistoke oil were about 10 times lower than the wear rates when lubricated by a three-centistoke oil. The measured

gear tooth wear rates strongly correlated to the lubricant viscosity.

Studies of rolling element bearings have shown that the bearing surface fatigue life is influenced by the lubricant viscosity and the surface roughness (Refs. 8-11). The influences have been condensed using the concept of specific film thickness, also often termed the “lambda ratio.” The specific film thickness is a ratio of the lubricating oil film thickness to the composite surface roughness of the two contacting surfaces. When the specific film thickness is less than unity, the service life of the bearing is considerably reduced. The Society of Tribologists and Lubrication Engineers (STLE) has published a recommended life factor for bearings that is a function of specific film thickness (Ref. 12). Some investigators have speculated that the effect of specific film thickness on gear life could be even more pronounced than is the effect on bearing life (Ref. 13). To improve the surface fatigue lives of gears, the film thickness may be increased, the composite surface roughness reduced—or both approaches may be adopted. These two effects have been studied separately for gears.

Townsend and Shimski (Ref. 14) studied the influence of viscosity on gear fatigue lives using seven different lubricants of varying viscosity. Tests were con-

ducted on a set of case-carburized and ground gears, all manufactured from the same melt of consumable-electrode vacuum-melted (CVM) AISI 9310 steel. At least 17 gears were tested with each lubricant. They noted a strong positive correlation of the gear surface fatigue lives with the calculated film thickness and demonstrated that increasing the film thickness does indeed improve gear surface fatigue life.

Several investigations have been carried out to demonstrate the relation between gear surface fatigue and surface roughness. One investigation by Tanka (Ref. 15) involved a series of tests conducted on steels of various chemistry, hardness, and states of surface finish. Some gears were provided with a near-mirror finish by using a special grinding wheel and machine (Ref. 16). The grinding procedure was a generating process that provided teeth with surface roughness quantified as  $R_{max}$  of about  $0.1 \mu\text{m}$  ( $4 \mu\text{in}$ ). A series of pitting durability tests were conducted and included tests of case-carburized pinions mating with both plain carbon steel gears and through-hardened steel gears. They concluded that the gear surface durability was improved in all cases because of the near-mirror finish. They noted that when a case-hardened, mirror-finish pinion was mated with a relatively soft gear, the gear became polished with running. They concluded that this polishing during running improved the surface durability of the gear.

Nakasuji (Refs. 17-18) studied the possibility of improving gear fatigue lives by electrolytic polishing. They conducted their tests using medium carbon steel gears and noted that the electro polishing process altered the gear profile and the surface hardness as well as the surface roughness. The polishing reduced the surface hardness and changed the tooth profiles to the extent that the measured dynamic tooth stresses were significantly larger relative to the ground gears. Even though the loss of hardness and increased dynamic stresses would tend to reduce stress limits for pitting durability, the electrolytic polishing was shown to improve the stress limit for which the gears were free of pitting by about 50 percent.

Hoyashita (Refs. 19-20) completed a third investigation of the relation between surface durability and roughness. They conducted a set of tests to investigate the effects of shot peening and polishing on the fatigue strength of case-hardened rollers. Some of the shot peened rollers were reground and some were polished by a process called barreling. The reground rollers had a roughness average (Ra) of  $0.78 \mu\text{m}$  ( $31 \mu\text{in}$ ). The polished rollers had a Ra of  $0.05 \mu\text{m}$  ( $2.0 \mu\text{in}$ ). Pitting tests were conducted using a slide-roll ratio of  $-20$  percent on the follower with mineral oil as the

lubricant. The lubricant film thickness was estimated to be  $0.15 \sim 0.25 \mu\text{m}$  ( $5.9 \sim 9.8 \mu\text{in}$ ). The surface durability of the rollers that had been shot peened and polished by barreling was significantly improved compared with rollers that were shot peened only or that were shot peened and reground. They found that the pitting limits (maximum Hertz stress with no pitting after 107 cycles) of the shot peened/reground rollers and the shot peened/polished rollers were  $2.15 \text{ GPa}$  ( $312 \text{ ksi}$ ) and  $2.45 \text{ GPa}$  ( $355 \text{ ksi}$ ), respectively.

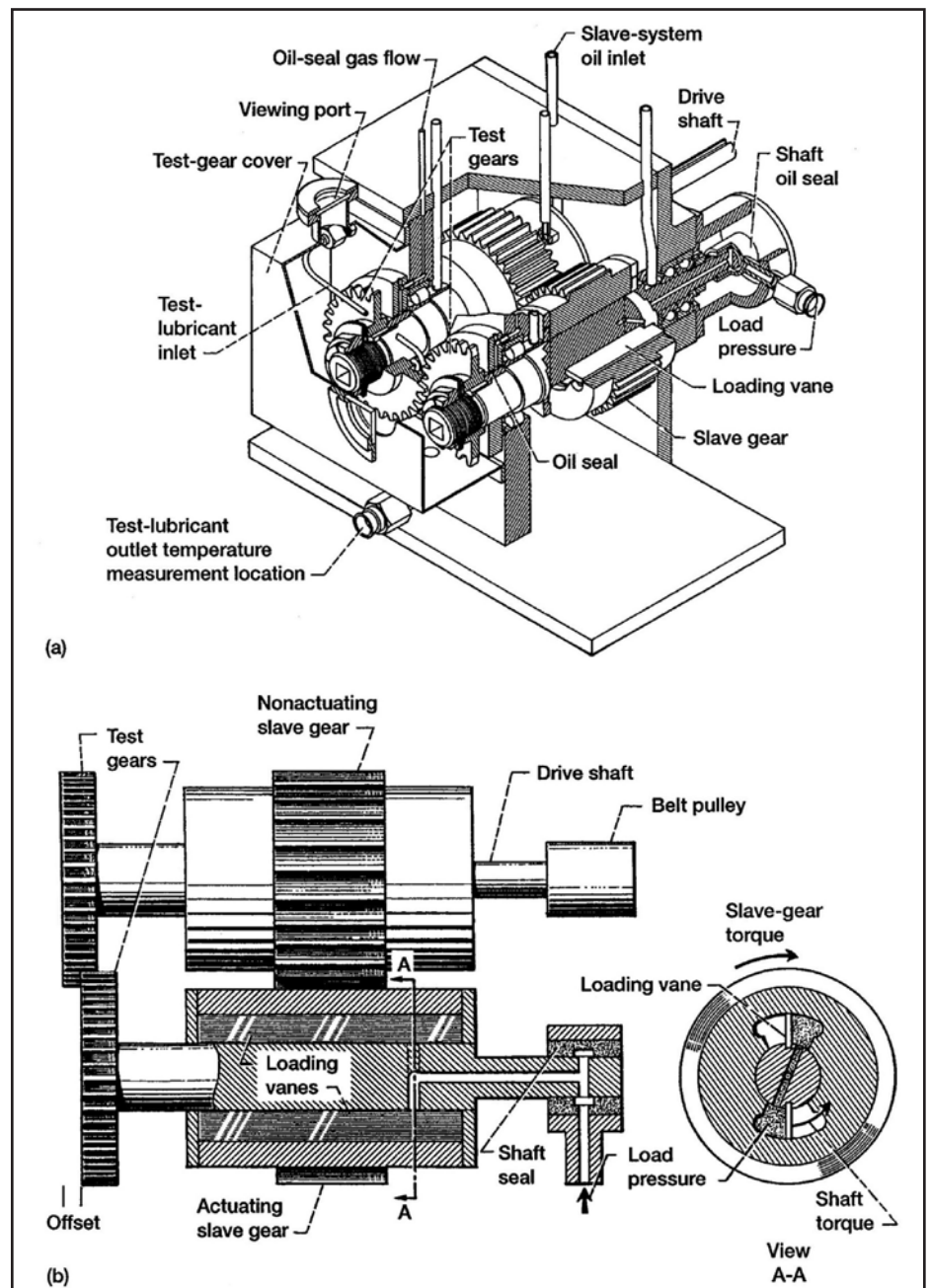

Figure 1 NASA Glenn Research Center gear fatigue test apparatus: (a) cutaway view; (b) schematic view.

Krantz (Refs. 21-22) studied the surface fatigue of gears with an improved surface finish using case-carburized gears made from AISI 9310 steel. Testing was done on the same high-speed power recirculating gear tester used by Townsend and Shimski (Ref. 14). The AISI 9310 gears with improved surface finish had longer lives as compared to standard ground gears by a factor of about four times. Motivated by these results, similar testing was later done using the same test rigs and test methods using gears made from aerospace quality, case-carburized AMS 6308B alloy steel (Ref. 23), and the relative life improvement was a factor of about three.

All of these previous works (Refs. 1-23) provide strong evidence that the specific film thickness parameter is an effective engineering concept for assessing the surface fatigue lives of gears. The review of previous works just presented is not exhaustive; other work has been published offering results that, from a qualitative view, are consistent with the preceding discussion. However, it has been difficult to combine the results of these studies of the surface fatigue lives of gears to provide a comprehensive quantitative correlation of the lubrication conditions and surface fatigue lives. Because of differing test rigs, specimen geometry, gear alloys and processing, and ranges of oper-

ating conditions such as speed and load, it is challenging to combine results. The present study was therefore carried out to quantify the correlation of the surface fatigue lives of gears to specific film thickness. In this work, experimental data from four studies are combined into one data set. All experiments were conducted on the NASA Spur Gear Test Rigs using consistent test procedures and test conditions (identical speed, torque, temperature, oil jetting and filtration, test gear geometry, and test gear manufacturing quality). This study comprises 258 gear surface fatigue tests. The fatigue data for the majority of the data set have been published previously (Refs. 14, 21 and 23). Townsend and Shimski (Ref. 14) reported results of gear tests using seven lubricants. Later, using gears made from the same melt of steel as used in (Ref. 14), Townsend completed an additional 50 tests using three more lubricants, but he did not widely disseminate the data. Those 50 fatigue tests are included into the data set for this study. Along with previously reported information in (Refs.

12, 21 and 23), many of the tested gears and laboratory records were still available, and access to this information provided a unique opportunity to compile sufficient detail of information to correlate the experimentally measured gear surface fatigue lives to a wide range of specific film thickness.

### Test Facility and Testing Procedure

The gear fatigue tests were performed in the NASA Glenn Research Center's gear test apparatus. The test rig is shown in Figure 1(a) and described in Reference 24. The rig uses the four-square principle of applying test loads, and thus the input drive only needs to overcome the frictional losses in the system. The test rig is belt driven and operated at a fixed speed for the duration of a particular test.

A schematic of the apparatus is shown in Figure 1(b). Oil pressure and leakage replacement flow is supplied to the load vanes through a shaft seal. As the oil pressure is increased on the load vanes located inside one of the slave gears, torque is applied to its shaft. This torque is transmitted through the test gears and back to the slave gears. In this way power is circulated, and the desired load and corresponding stress level on the test gear teeth may be obtained by adjusting the hydraulic pressure.

The two identical test gears may be started under no load, and the load can then be applied gradually. To enable testing at the desired contact stress, the gears are tested with the faces offset as shown in Figure 1. By utilizing the offset arrangement for both faces of the gear teeth, a total of four surface fatigue tests can be run for each pair of gears. The test

Table 1 Spur test gear design parameters	
Number of teeth	28
Module, mm	3.175
Diametral pitch (1/in)	8
Circular pitch, mm (in)	9.975 (0.3927)
Whole depth, mm (in)	7.62 (0.300)
Addendum, mm (in)	3.18 (0.125)
Chordal tooth thickness ref. mm (in)	4.85 (0.191)
Pressure angle, deg.	20
Pitch diameter, mm (in)	88.90 (3.500)
Outside diameter, mm (in)	95.25 (3.750)
Root fillet, mm (in)	1.02 to 1.52 (0.04 to 0.06)
Measurement over pins, mm (in)	96.03 to 96.30 (3.7807 to 3.7915)
Pin diameter, mm (in)	5.49 (0.216)
Backlash reference, mm (in)	0.254 (0.010)
Tip relief, mm (in)	0.010 to 0.015 (0.0004 to 0.0006)

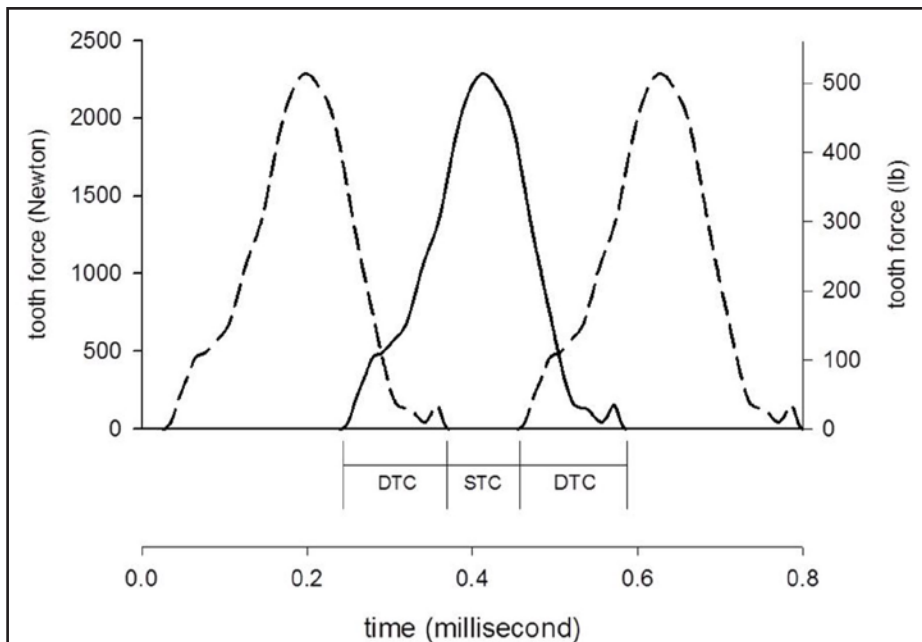

Figure 2 Measured dynamic tooth force at nominal test conditions (Ref. 22). The solid line is the measured data, and the dashed lines are replicates of the measured data spaced along the ordinate at the equivalent of one tooth pitch. The zones of double tooth contact (DTC) and single tooth contact (STC) are illustrated.



gears were run with the tooth faces offset by a nominal 3.3 mm (0.130 in) to give a nominal surface load width on the gear face of 3.0 mm (0.120 in). The precise width of the running track will be influenced by gear tooth facewidth tolerances and by the shape and radius of the edge breaks. In this work, post-test inspections were used to determine the running track widths, as will be discussed later in this report.

All tests were run-in at a torque load of 14 Nm (130 in-lb) for at least one hour. The torque was then increased to the test torque of 72 Nm (640 in-lb). For this test torque, the peak of the Hertz pressure distribution for line contact condition at the pitch-line and static torque equilibrium is 1.7 GPa (250-ksi). Typical dynamic tooth forces have been measured using strain gages located in tooth fillets. Using calibration coefficients determined by specialized calibration experiments (Ref. 25) typical gear tooth forces were calculated from measured tooth fillet strains (Fig. 2). The resulting peak dynamic tooth force is about 1.3 times greater than the force for static equilibrium, and the resulting peak of the Hertz pressure distribution for this peak dynamic force is 1.9 GPa (285 ksi). The Hertz pressure values stated herein are idealized stress indices assuming perfectly smooth surfaces and an even pressure distribution across a 2.79 mm (0.110 in) line contact (the line length is less than the face width allowing for the face offset and the edge break radius).

The gears were tested at 10,000 rpm, which gave a pitch-line velocity of 46.5 m/s (9,154 ft/min). Inlet and outlet oil temperatures were continuously monitored. Cooled lubricant was supplied to the inlet of the gear mesh at 0.8 liter/min (49 in/min) and  $320 \pm 7\text{K}$  ( $116 \pm 13^\circ\text{F}$ ). The lubricant outlet temperature was recorded and observed to have been maintained at  $348 \pm 4.5\text{K}$  ( $166 \pm 8^\circ\text{F}$ ). The lubricant was circulated through a  $5\mu\text{m}$  ( $200\mu\text{in}$ )-rated fiberglass filter to remove wear particles. For each test, 3.8 liters (1 gal) of lubricant were used.

The tests ran continuously (24 hr/day) until a vibration detection transducer automatically stopped the rig. The transducer is located on the gearbox, adjacent to the test gears. For purposes of this work, surface fatigue failure was defined

as one or more spalls, or pits, covering at least 50 percent of the width of the line contact on any one tooth. If the gear pairs operated for more than 500 hours (corresponding to 300 million stress cycles) without failure, the test at the test engineer's discretion was usually suspended. Some superfinished gears were operated for longer than 300 million cycles. The longest test exceeded 1,000 hours (600 million cycles) without surface fatigue occurring.

### Test Gears

The dimensions for the test gears are given in Table 1. The gear pitch diameter was 89 mm (3.5 in) and the tooth form was a  $20^\circ$  involute profile modified to provide linear tip relief of 0.013 mm (0.0005 in) starting at the highest point

of single tooth contact. The gears have no lead crowning, but do have a nominal 0.13 mm (0.005 in) radius edge break at the tips and sides of the teeth. The gear tooth surface finish after final grinding was specified as a maximum of  $0.406\mu\text{m}$  ( $16\mu\text{in}$ ) rms. Tolerances for the gear geometries were specified to meet AGMA 2000-A88 quality level class 12 (Ref. 26). Typical data from gear coordinate measurement machine inspections to verify the gear involute and lead form quality are provided in Figure 3.

All gears included in this study were made from forged bars; the gears were made from two alloys. One alloy was per specification AISI 9310, the other per specification AMS 6308B. The chemical compositions of the two alloys are given in Table 2. All of the gears made from

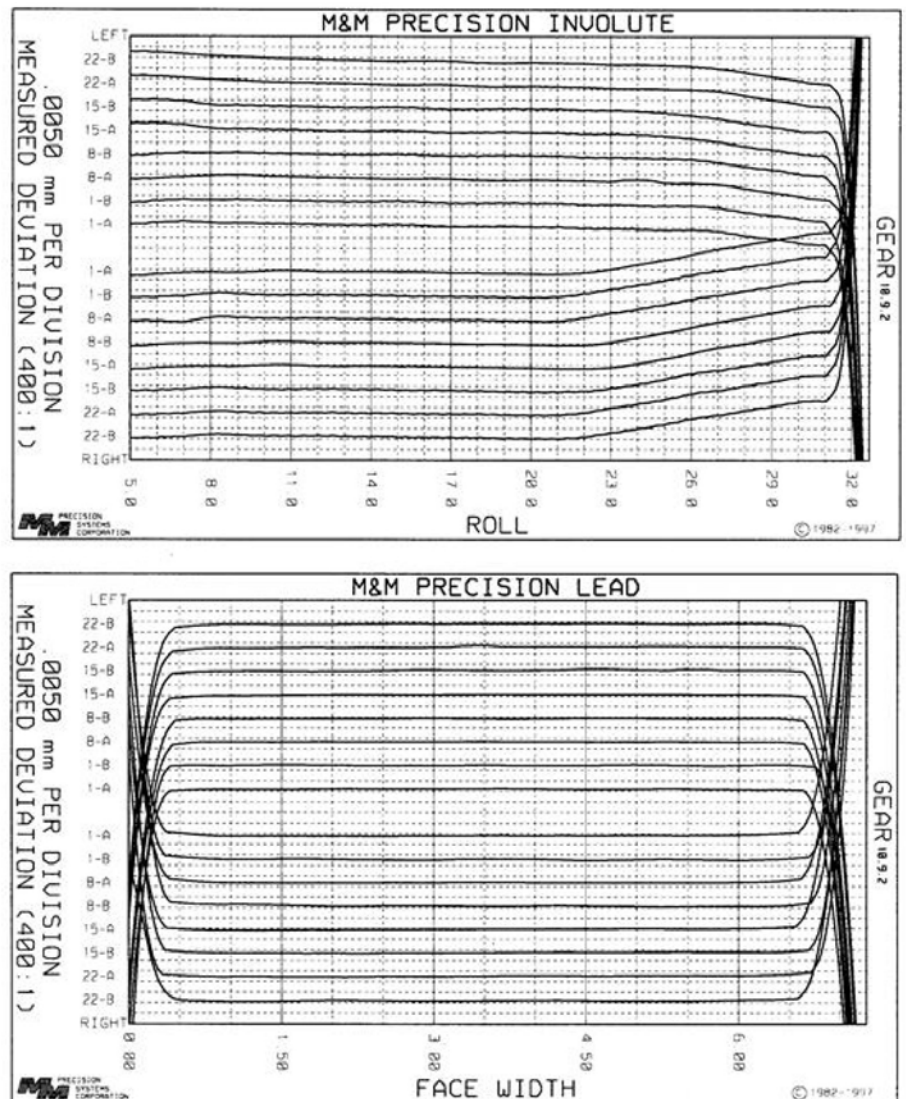

**Figure 3** Involute and lead inspection charts of a typical 28-tooth test gear. Two lead and involute traces for both sides of teeth 1, 8, 15 and 22 are shown (NOTE: Aspect ratio of plot is scaled as X:Y=100:1.)

AMS 6308B were made from a single melt of vacuum-induction melt vacuum arc re-melt (VIM-VAR) processed steel, and were manufactured as a single lot; i.e. — all rough machining, hobbing, heat treatment, and final grinding were accomplished together as a single lot of gears. The gears made from AISI 9310 steel were from two melts of steel; one melt made via air-melt vacuum-arc-re-melt (VAR) process and the other melt made using a consumable electrode vacuum melt process (CVM). One can expect that the CVM-processed steels had fewer impurities than did the VAR steel. The gears made from the VAR 9310 were manufactured in one lot; those made from the CVM 9310 steel were made in three lots. Gears were case-carburized and tempered following aerospace practice to achieve a surface hardness of minimum Rc 58 — with a typical surface hardness of Rc 60 and case depth of 1.0 mm (0.040 inch). Additional details concerning the heat treatment process, typical microstructure of case and core, hardness profiles, residual stress profiles and surface metrology are available in (Refs. 13, 14, 21-22, 23 and 27).

To correlate the specific film thickness to gear fatigue lives, the surface roughness of the test gears is needed. As just mentioned, gears were made from three melts of steel. Furthermore, for one of the melts, gears were made in three lots — for a total of five manufacturing runs of gears with ground teeth. For two studies of superfinishing a lot of ground gears was divided into two groups — one group remaining in the as-ground condition and the other subjected to superfinishing. Therefore, in total there were seven groups of gears — five groups with ground surfaces and two groups with superfinished surfaces.

Superfinishing was done using one of two processes described in (Refs. 3 and 7). The surface roughness for each of the seven gear groupings was re-measured and quantified using the root-mean-squared roughness parameter ( $Rq$ ). Measuring was done using a 2- $\mu$ m radius, conisphere-tipped stylus profilometer, and the data were digitally processed using an ISO-conforming Gaussian roughness filter having a 0.8 mm cutoff.

The 0.8 mm cutoff is a value typically available for many surface rough-

ness measuring instruments and software. In this work the concept of “functional filtering” was employed. The concept is that the concentrated contact acts as a mechanical filter, and therefore the wavelengths of surface roughness that influence the machine element performance depend on the breadth of the contact. Using a line-contact assumption, the gear geometry, operating torque and classical Hertz contact theory, the breadth of the Hertz contact at the pitch point was calculated as 0.47 mm — a smaller length than the 0.8 mm value of the cutoff for the digital filter. The roughness values were therefore adjusted by the method proposed by Moyer and Bahney (Ref. 28), and also recommended by the AGMA (Ref. 29) as:

$$Rq_{eff} = Rq_{0.8mm} \sqrt{\frac{A}{0.8}} \quad (1)$$

where

$Rq_{eff}$  is effective roughness parameter

$Rq_{0.8mm}$  is roughness parameter determined using a 0.8 mm filter cut-off value

A is contact breadth in direction of rolling, millimeters

Typical plots of surface topography of gear teeth, as measured by profilometer tracing after application of the roughness filter to the data, for three lots of the

Table 2 Spur test gear steel chemical compositions

Element	AISI 9310 <sup>1)</sup>	AMS 6308B <sup>2)</sup>
	Weight %	
Carbon	0.10	0.11
Nickel	3.22	1.84
Chromium	1.21	1.07
Molybdenum	0.12	3.32
Copper	0.13	2.06
Manganese	0.63	0.38
Silicon	0.27	0.77
Sulfur	0.005	< 0.005
Phosphorous	0.005	< 0.010
Vanadium	N/A	0.08
Iron	Balance	Balance

NOTES:

1) Nominal composition per specification

2) Verified composition and within specification

ground gears tested by Townsend and Shimski (Ref. 14), are provided (Fig. 4). Note that each set has a differing surface texture and roughness value.

Although not directly stated by Townsend and Shimski (Ref. 14), when they presented a correlation of fatigue data to specific film thickness, they used the maximum  $Rq$  roughness value permitted by their test gear specification to estimate the specific film thickness. So, while the correlation they provided is qualitatively consistent with the correlation to be derived herein, their correlation is quantitatively different from the present work because they did not account for differing actual roughness of test gears in their correlation, and they did not employ the concept of functional filtering.

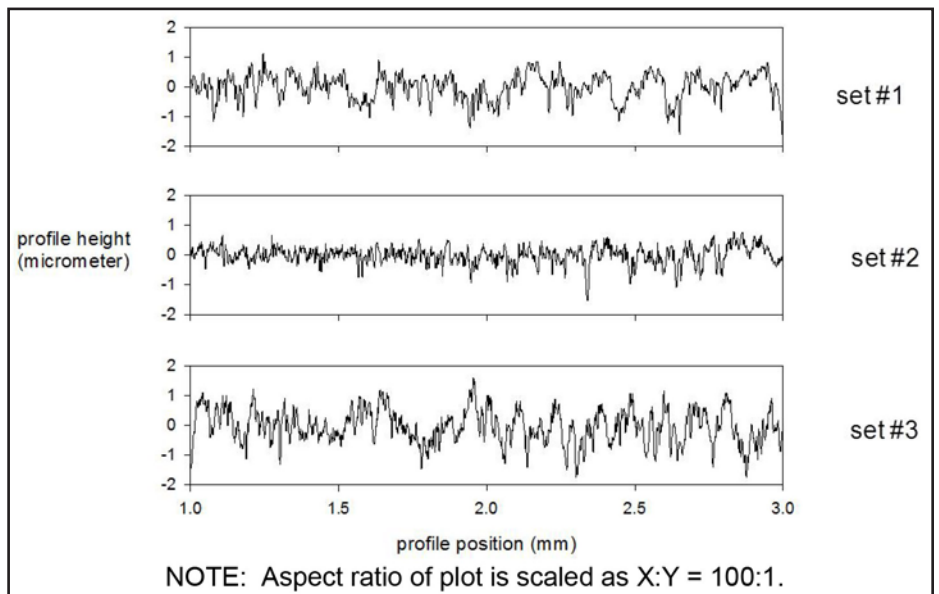

Figure 4 Examples of surface roughness data after application of roughness filter with a 0.8 mm cutoff. The three sets are ground gears manufactured from the same melt and to same specification, but from three different manufacturing lots.

Figure 5 provides a pair of typical surface roughness data sets for the ground and superfinished gears included in this study. The measurements were made with aid of a fixture and a precision-relocation technique (Ref. 27) such that the roughness was measured at the same position on the tooth—both before and after superfinishing. The superfinish processes removed asperity features and, as a result, only valley features of relatively small depths remained. The superfinishing resulted in a near-mirror surface quality (Fig. 6).

The  $Rq_{eff}$  effective roughness parameter for each of the seven groups of gears in this study ranged from 0.07-0.45  $\mu\text{m}$  (2.7-17.9  $\mu\text{in}$ ). The full set of data is provided in Table 3. For sets denoted as set IDs 4-7 in Table 3, the  $Rq$  parameters were calculated from previously published Ra values using the following relationship (Ref. 27) to estimate  $Rq$  from Ra (Ref. 30):

$$Rq = \sqrt{\left(\frac{\pi}{2}\right)} \quad (2)$$

### Lubricants and Specific Film Thickness

The tests considered in this study made use of twelve different lubricants. The lubricant viscosity at (95-100°C) ranged from 3.2-9.1 cSt. Most of the lubricants were fully formulated lubricants, including proprietary additive mixtures. Nine of the 12 lubricants were polyolesters; the other three lubricants were a polyalkylene-glycol, a naphthenic mineral oil, and a synthetic paraffinic. The synthetic paraffinic is termed herein as “NASA standard”-lubricant, as this lubricant has

Reference	Material	Set ID	Finish method	Roughness, $Rq$ , $\mu\text{m}$ ( $\mu\text{in}$ )
[14]	CVM AISI 9310	1	Ground	0.42 (16.7)
		2	Ground	0.24 (9.4)
		3	Ground	0.45 (17.9)
[21]	AM-VAR AISI 9310	4	Ground	0.37 (14.6) <sup>1)</sup>
		5	Superfinished	0.07 (2.7) <sup>1)</sup>
[23]	VIM-VAR AMS 6308B	6	Ground	0.32 (12.7) <sup>1)</sup>
		7	Superfinished	0.08 (3.3) <sup>1)</sup>

NOTE:

1) Denotes  $Rq$  calculated from published Ra values.

been used in the manner of a reference lubricant for many gear fatigue studies, including more than 140 tests of AISI 9310 steel gears (Ref. 22). The NASA standard lubricant includes 5% additive by volume; the additive content includes phosphorous and sulphur. For all tests the lubricants were filtered using a 5-micron-rated fiberglass filter element.

The operating film thickness for each lubricant was calculated using the minimum-film-thickness equation (Ref. 31). The dimensionless (normalized) formula used was:

$$H_{min,r} = 2.65U^{0.70} G^{0.54} W^{-0.13} \quad (3)$$

where

$U$  is speed parameter, proportional to the absolute viscosity of the lubricant

$G$  is material parameter, proportional to the pressure-viscosity coefficient of the lubricant

$W$  is load parameter, independent of the lubricant

The needed lubricant physical parameters were obtained from referenced works (Refs. 14, 22 and 23), in most cases. Some of the needed lubricant physical param-

eters had not been published, but were determined from laboratory records and notes of Townsend (Refs. 13-14). The lubricant physical properties are functions of temperature. For purposes of calculating film thickness, the lubricant properties used were those for the mean of the oil jet and oil outlet (drain) temperatures, i.e. — 330°K (57°C, 134°F). The minimum film thicknesses as calculated from Equation 3 ranged from 0.28-0.75  $\mu\text{m}$  (11-30  $\mu\text{in}$ ).

Combining the results of surface roughness evaluations (Table 3) and the minimum film thickness calculations, the specific film thickness ratio was determined for each of the 14 groups of gears that were subjected to fatigue tests. Note that the roughness value to be used for the specific film thickness calculation is the composite roughness for both gears, while the table lists the roughness for one surface. The lubricants tested and the combinations of roughness, film thickness, and resulting specific film thickness values are listed in Table 4. The range of specific film thickness for this study is (0.47-5.23).

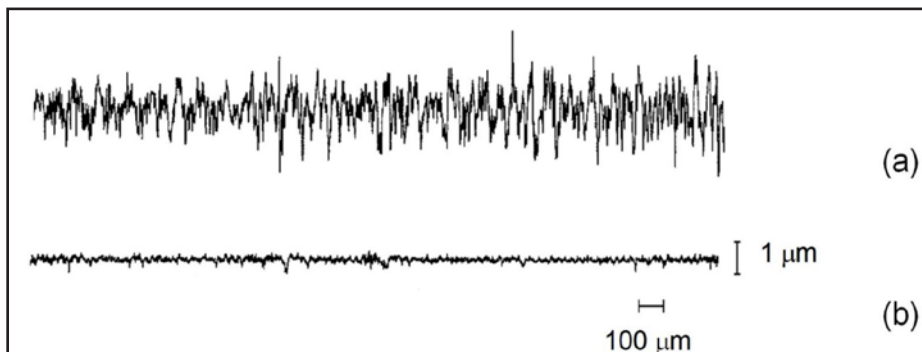

Figure 5 Examples of surface roughness features for a gear tooth prior to and after superfinishing, (Ref. 27): (a) ground surface; (b) same surface (relocated profile trace) after superfinishing.

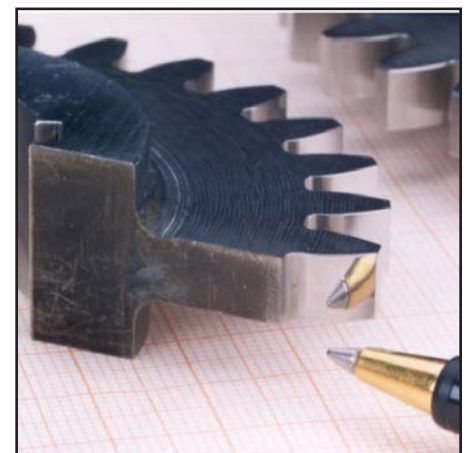

Figure 6 Near-mirror quality of a superfinished test gear.

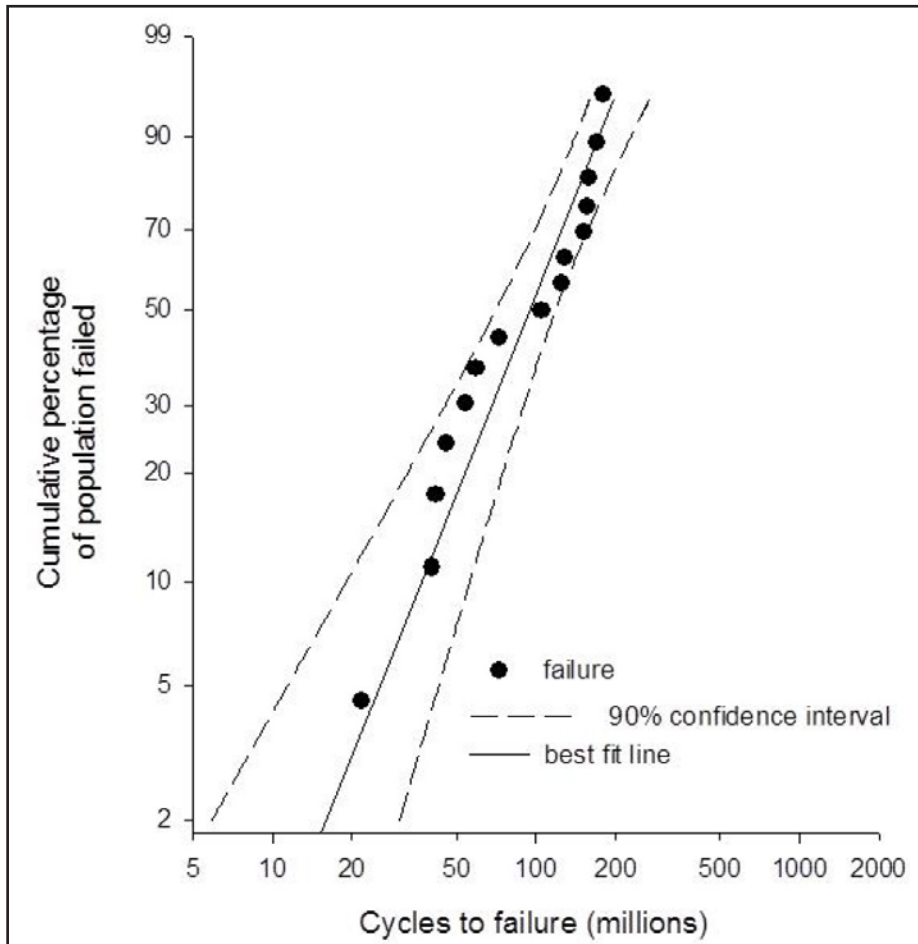

**Table 4** Lubricant details, calculated film thickness, roughness of the test gears, and resulting specific film thickness

Dataset	Lubricant description	Specification	Viscosity at 95-100 °C, cSt	Film thickness, $\mu\text{m}$	Roughness, $Rq_{\text{eff}}$	Specific film thickness
1	Polyolester	MIL-L-7808	3.2	0.28	0.42	0.47 <sup>2)</sup>
2	Polyolester	None <sup>1)</sup>	4.3	0.40	0.42	0.67 <sup>2)</sup>
3	Polyolester	MIL-L-23699	5.2	0.48	0.45	0.75 <sup>2)</sup>
4	Polyolester	DOD-L-85734	5.2	0.51	0.42	0.86 <sup>2)</sup>
5	Polyolester	DOD-L-85734	5.4	0.51	0.42	0.86 <sup>2)</sup>
6	Polyolester	MIL-L-23699	5.4	0.52	0.42	0.87 <sup>2)</sup>
7	Polyalkylene-glycol	DERD 2487	7.4	0.65	0.42	1.09 <sup>2)</sup>
8	Polyolester	None <sup>1)</sup>	8.8	0.72	0.24	2.14 <sup>2)</sup>
9	Polyolester	None	9.0	0.73	0.24	2.17 <sup>2)</sup>
10	Polyolester	None	9.1	0.75	0.24	2.23 <sup>2)</sup>
11	Polyolester	DOD-L-85734	5.4	0.51	0.07	5.23 <sup>3)</sup>
12	Naphthenic mineral oil	None	7.1	0.60	0.37	1.15 <sup>3)</sup>
13	Synthetic paraffinic	"NASA Stnd"	5.7	0.50	0.32	1.10 <sup>4)</sup>
14	Synthetic paraffinic	"NASA Stnd"	5.7	0.50	0.08	4.20 <sup>4)</sup>

**NOTES:**

- 1) Base stock lubricants, no additives.
- 2) Study #1, refers to referenced works [14, 21, 23].
- 3) Study #2, refers to referenced works [14, 21, 23].
- 4) Study #3, refers to referenced works [14, 21, 23].
- 5) Datasets 3, 5 and 10 were part of study #1, but the data had not been previously published.



**Figure 7** Typical distribution of gear fatigue test data plotted using Weibull coordinates and showing median-rank regression solution (solid line) and 90% confidence interval (dashed lines).

**Fatigue Test Results, Statistics, and Method for Normalizing Results**

Gear fatigue tests were completed for 14 groups of gears — each group being a unique combination of alloy, surface finish roughness, and lubricant. All gears were tested on the NASA Spur Gear Test Rigs using the same torque, speed, lubricant temperatures, and test procedures. Some tests were suspended with no fatigue and no indications of pending fatigue, and so such results were treated as suspended fatigue tests. Tests that were suspended completed at least 500 test hours (300 million shaft revolutions). The longest test, one using superfinished surfaces, was suspended after 1,000 hours (600 million cycles).

All of the gear failures were surface fatigue failures. This term is used to include what is sometimes considered two separate failure modes — sub-surface spalling and near-surface, or surface-originating pitting. In this work there was no attempt to determine or differentiate test results as spalling or pitting. Rather, all failures are grouped together and termed as “surface fatigue.” None of the failures were of the micropitting failure mode. A surface-fatigue life evaluation for a particular group of gears comprised multiple tests, as the scatter for such fatigue tests is significant. The number of tests completed for each group ranged from 10 to 30. The average number of tests per group — average statistical sample size — was 18. The fatigue test results for each of the 14 groups of gears were modeled as best-fit, two-parameter Weibull distributions. The parameters for the best-fit Weibull distributions were determined by median-rank regression (Ref. 32). The Weibull shape parameters (slopes) for the regression solutions ranged from 1.0-2.6. A typical Weibull plot of the gear fatigue data is provided in Figure 7. From the Weibull regression solutions, the 10 percent lives (L10) were determined for each gear group. The determined (best-fit) L10 lives ranged from 5.1-100 million cycles. The total number of tests included in this study is 258 tests.

During careful inspections of the tested gears, one notes slight differences in the widths of the running tracks. Further study would reveal that the running track

widths are very consistent for all gears of a particular manufacturing lot, but the running track widths varied somewhat from lot-to-lot because of two primary factors. One factor is that the gear face widths were specified with a tolerance of  $\pm 0.13$  mm (0.005 inch). The second factor influencing the running track width is that the edge breaks vary in details from lot-to-lot — even though all are within specification. As the test torque was the same, but the running track widths varied, the load intensity for all tests was not identical. To best correlate fatigue test results to specific film thickness, the fatigue lives at common load intensity was desired.

Therefore, the fatigue lives were adjusted to account for the varying load intensity. All tests were normalized to a line-contact load intensity (load divided by Hertz line-contact width) of 580 N/mm at the pitch line. This was done with the aid of digital photographs of the tested gears recorded using a low-objective-power microscope and small aperture setting to obtain needed resolution and depth-of-field.

The wear tracks were measured with the aid of image-processing software. The L10 fatigue lives were adjusted to estimate the results as if all tests had been operated at the same load intensity using the following relation (Ref. 33):

$$L_{10} \propto \text{load intensity}^{-4.3} \quad (4)$$

The load-life exponent of Equation 4 is one that was determined by tests of 9310-steel gears using the same rigs and test procedures as for the present study. One additional normalizing factor was applied to the two groups of gears made from AM-VAR melted materials, made in the 1970's era, to be directly compared on an absolute basis to VIM-VAR processed material made approximately 30 years later. A life adjustment factor of 2.0 was applied to the L10 lives of the AM-VAR gears to estimate the experiment results if such experiments were to be repeated using VIM-VAR material (Ref. 12). With these adjustments, a set of adjusted L10 lives was determined that could, as a cohesive set, be correlated to specific film thickness. The resulting data are provided in Table 5; included in Table 5, for ease of study, are the specific film thickness data from Table 4.

Dataset	Weibull L10, 10 <sup>6</sup> cycles	Contact width, mm	Load intensity, N/mm	Relative load intensity <sup>1)</sup>	Adjusted L10 lives, 10 <sup>6</sup> cycles	Specific film thickness
1	5.7	2.65	657	1.132	9.72	0.47 <sup>2)</sup>
2	5.1	2.65	657	1.132	8.69	0.67 <sup>2)</sup>
3	11	3.02	576	0.993	10.7	0.75 <sup>2)</sup>
4	12	2.95	590	1.017	12.9	0.86 <sup>2)</sup>
5	35	2.95	590	1.017	37.6	0.86 <sup>2)</sup>
6	12	2.65	657	1.132	20.5	0.87 <sup>2)</sup>
7	47	2.95	590	1.017	50.5	1.09 <sup>2)</sup>
8	45	3.10	561	0.968	39.1	2.14 <sup>2)</sup>
9	100	3.10	561	0.968	86.8	2.17 <sup>2)</sup>
10	84	3.10	561	0.968	73.0	2.23 <sup>2)</sup>
11	46	2.80	621	1.071	85.7	5.23 <sup>3)</sup>
12	11	3.05	570	0.984	29.6	1.15 <sup>3)</sup>
13	37	3.00	580	1.000	37.0	1.10 <sup>4)</sup>
14	75	3.00	580	1.000	75.0	4.20 <sup>4)</sup>

**NOTES:**

- 1) Normalized to a running load intensity of 580 N/mm.
- 2) Study #1, refers to referenced works [14, 21, 23].
- 3) Study #2, refers to referenced works [14, 21, 23].
- 4) Study #3, refers to referenced works [14, 21, 23].

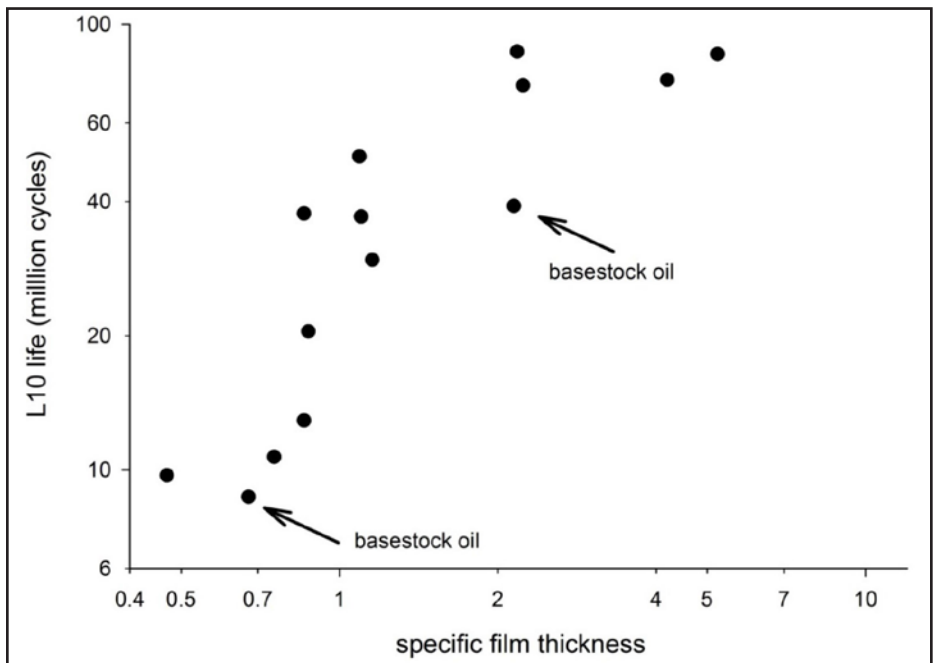

**Figure 8** Trend of adjusted L10 lives as a function of specific film thickness displayed using log-log scaling; test results using base stock oils (without additives) are noted by arrows.

### Results, Correlations and Comparisons

The correlation of the gear surface fatigue lives to the specific film thicknesses were studied by a variety of plots and comparisons to other work and data presentations. Presented first is the data of the present study, plotted using log-log scales (Fig. 8). From this plot one observes features that are qualitatively consistent with the literature, namely:

There is a strong correlation of surface fatigue life to the specific film thickness.

Over the range of specific film thickness of this study, the correlation is non-linear. Even with the use of log-log scales there is evidence of curvature to the correlation trend.

Gears operating near or above a specific film thickness of about two can operate for significantly longer time without surface fatigue (by a life-multiplying factor of approximately 8~10), as compared to gears operating at a specific film thickness of less than 0.8.



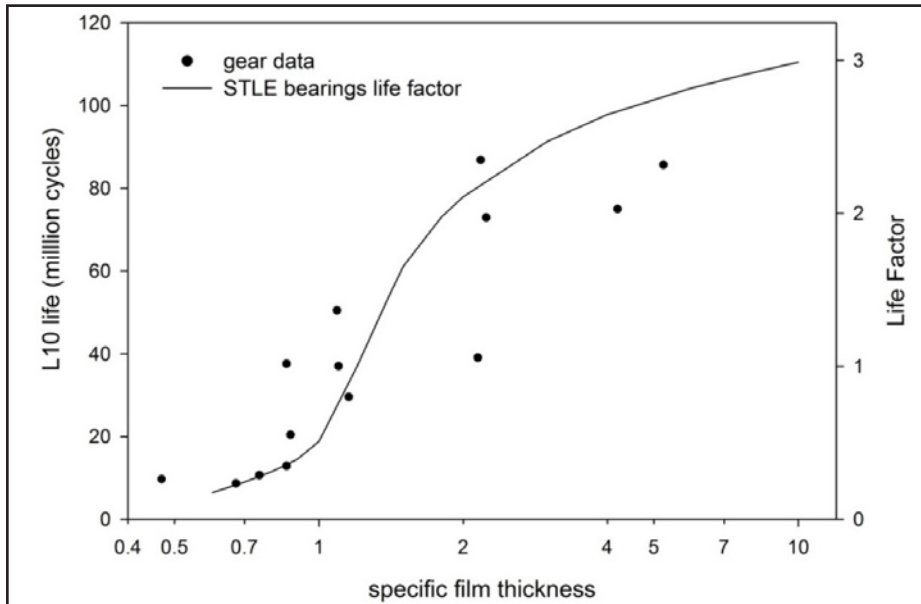

Figure 9 Comparison of the data of the present work using gears (data points) to life adjustment factor correlation recommended for life ratings of bearings (Ref. 12) (solid line).

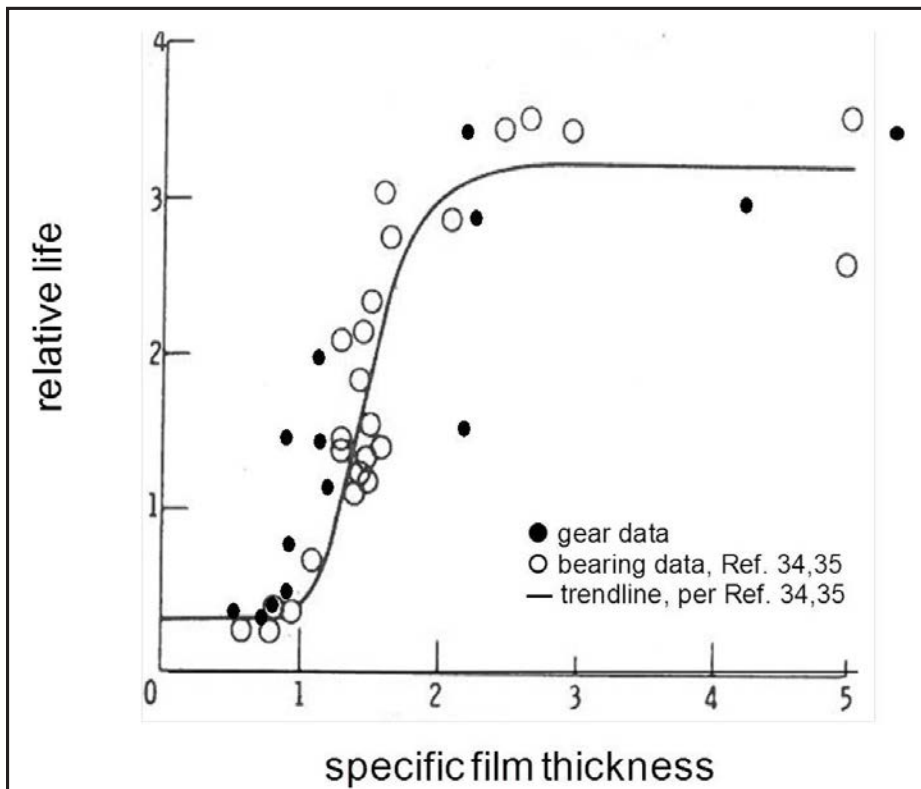

Figure 10 Compilation of the bearing life data of Skurka (Refs. 34-35) for cylindrical and tapered roller bearings (open symbols) and the gear life data of this study (solid symbols).

Also noted in Figure 8 are the two surface fatigue L10 life estimates for the gears tested using base stock oils without additives. It is interesting to note that these two data points tend toward lower bounds of the visual trend of life with specific film thickness. This perhaps points out the importance of not only the specific film thickness but also lubricant chemistry. This importance of additives is not surprising for the mixed-lubrication regime (specific film thickness ~0.7), but perhaps the additives and chemistry also play important roles even for lubrication regimes approaching “full lubrication.” One should keep in mind that the specific film thickness is a separation of the “mean” levels of surfaces, and a specific film of one or even two does not guarantee separations of all asperity features.

The relationship of L10 surface fatigue lives to specific film thickness can be displayed by plotting the data of Table 5 in the manner of the life factor relationship for rolling-element bearings, as recommended by STLE (Ref. 12). The resulting plot of the present study — with comparison to the practice for bearings — is provided in Figure 9. This plot uses semi-log scales, matching the method of display of (Ref. 12). The gear data of this study is presented using symbols, while the STLE bearing rating life factor is presented by a line. The STLE life factor was scaled by a multiplier of  $37 \times 10^6$  to provide this comparison. This scaling factor was selected to provide a “good fit by eye.” We note that the gear data largely matches the trends of the bearing life factor curve. One can judge that the speculation that the influence of specific film thickness may be greater for gear life than for bearing life (Ref. 13) is not supported by the data of this study (Fig. 9).

Another bearing data set that provides an interesting comparison is the data of Skurka (Ref. 34) discussed by Anderson (Ref. 35). The data are for cylindrical and tapered rolling-element bearings. These bearings have rectangular-shaped contacts like the spur gears of this study. The data plot from (Ref. 25) was scanned and the data of this study were normalized to provide the same relative life range as for the bearings, and the gear data was overlaid. The resulting plot of the combined data set (Fig. 10) has open symbols for the bearing data, closed symbols for the

gear L10 data, and a trend line suggested by Skurka. The bearing and gear data are quite similar — suggesting three regimes. There is a low-specific film thickness regime with relative life near 0.3, and a high-specific film thickness regime with relative life near three. The third regime is the transition regime for specific film of about 0.8 to about 2.5.

Some guidance for estimating gear life with respect to surface durability is given in AGMA 925-A03 (Ref. 29).

In this approach, a rating factor of the allowable stress is given as a function of the lubrication regime.

Three equations are stated, each one a straight line on log-log scales but having different slopes for each of three lubrication regimes. “Boundary lubrication,” or Regime I, is defined as a specific film thickness less than 0.4. The “mixed lubrication,” or Regime II, is for specific films in the range 0.4-1.0. The “full-EHL” Regime III is slated to begin for specific films greater than 1.0. The calculations to follow allow for a comparison of the AGMA 925-A03 method to the data of this study. From Figure 8, for the largest specific film thicknesses tested (full-EHL or Regime III) the L10 lives were about 80 million. Substituting this value for cycles into the AGMA equation for Regime III, the stress factor  $Z_n$  is 0.89. Now using this value for the  $Z_n$  stress factor and using the equation for Regime II (mixed lubrication), one can solve for the expected life — yielding 5.6 million. From Figure 8, the experimental data for the smallest specific film value (0.47) was a life of about 9 million. Expressing life for the beginning of the mixed-lubrication regime as a percentage of the life in the full lubrication regime, the AGMA method and the data of this study yield similar percentages — seven percent and 11 percent, respectively. The present study complements the AGMA method in helping establish the quantitative relationship in the transition between the mixed- and full-lubrication regimes.

Gear surface fatigue lives are directly correlated to the specific film thickness. The trend of the gear lives as a function of specific film is nonlinear, with a dramatic increase on the order of 8~10 times longer lives for gears operating with full film lubrication, as compared to gears operating with mixed lubrication.

## Summary

In this work, gear fatigue test results from previous studies were collected, studied, and assessed so as to create a single, cohesive set of 258 gear fatigue tests that together enable a quantitative correlation of specific film values to gear surface fatigue lives. The gear tests made use of 12 lubricants with viscosities ranging from 3.2-9.1 cSt. The majority of gears in this study had ground surfaces. Two gear groups tested had superfinished surfaces. All gears were made from aerospace-grade gear steels and were case-carburized. All 258 tests were completed using the same rigs, torque, speed, lubricant temperatures, and by following the same test procedures.

This study comprised 14 groups of gears that were tested for surface fatigue, each group being a unique combination of alloy, surface finish roughness, and test lubricant. For each gear group, the surface fatigue test results were used to estimate the 10 percent lives (L10 lives) by modeling the fatigue life dispersions as two-parameter Weibull distributions and fitting the data using the least-squares median rank method. The average statistical sample size was 18.

The estimated L10 lives were adjusted to account for slight differences in load intensity due to lot-to-lot variations of gear tooth face width and edge breaks. The actual load intensities were determined by measuring the running track widths from microscope photos of tested gears, and then L10 lives normalized to common load intensity. The adjusted L10 lives of the 14 test gear groups ranged from 8.7-86.8 million cycles.

Specific film values were determined using film thickness calculated by Dowson’s formula for line contacts, applying the formula to the pitch-line operating conditions. The surface roughness values used for the specific film thickness calculation were ones measured by stylus profilometer, digitally filtered using a 0.8 mm cutoff, and further adjusted using the concept of functional filtering. The specific film values for this study ranged from 0.47-5.2.

The adjusted L10 lives have a strong correlation to specific film values. The trend is one of increasing life for increasing specific film. The trend is nonlinear. The observed trends were found to be in

good agreement with data and recommended practice for bearings. The L10 lives of this study in the mixed-lubrication regime were about 11 percent of the lives in the full-film-lubrication regime. This quantitative result is consistent with the relative values, as calculated by the methods of AGMA 925-A03. The specific film parameter concept has certainly been influencing the gearing practice for some time. The results obtained in this study will perhaps allow for the specific film parameter to be used with more confidence and precision to assess gear surface fatigue for purposes of design, rating, and technology development. 

## References

1. Borsoff, V., “On the Mechanism of Gear Lubrication,” *Journal of Basic Engineering*, 1959.
2. Patching, M., C. Kweh, H. Evans and R. W. Snidle. “Conditions for Scuffing Failure of Ground and Superfinished Steel Disks at High Sliding Speeds Using a Gas Turbine Engine Oil,” *J. of Tribology*, 117 (3), 482-489, 1995.
3. Winkelmann, L.W., M.D. Michaud, R.W. Snidle and M.P. Alanou. “Effect of Superfinishing on Scuffing Resistance,” *ASME Design Engineering Technical Conferences*, DETC2003-48124, Chicago, September 3-6, 2003.
4. Liou, J.J. “A Theoretical and Experimental Investigation of Roller and Gear Scuffing,” Ph.D. Dissertation, The Ohio State University, Columbus, Ohio, 2010.
5. Li, S., A. Kahraman, N. Anderson and L.D. Wedeven. “A Model to Predict Scuffing Failures of a Ball-on-Disk Contact,” *Tribology International*, 60, 233-245, 2012.
6. Brenneman, J.W. “An Experimental Study on the Scuffing Performance of High-Power Spur Gears at Elevated Oil Temperatures.” M.S. Thesis, The Ohio State University, Columbus, Ohio, 2013.
7. Krantz, T., Kahraman, A., *An Experimental Investigation of the Influence of the Lubricant Viscosity and Additives on Gear Wear*, Tribology Transactions, 47, 138-148, 2004.
8. Anderson, W., R. Parker and E. Zaretsky. “Effect of Nine Lubricants on Rolling-Contact Fatigue Life,” NASA TN D-1404, 1962.
9. Anderson, W., L. Sibley and E. Zaretsky. “The Role of Elastohydrodynamic Lubrication in Rolling-Contact Fatigue,” *J. of Basic Eng.*, 85, 1963.
10. Liu, J., T. Tallian and J. McCool. “Dependence of Bearing Fatigue Life on Film Thickness to Surface Roughness Ratio,” *ASLE Trans.*, 18 (2), 1975.
11. Skurka, J., “Elastohydrodynamic Lubrication of Roller Bearings,” *Trans. of the ASME, Journal of Lubrication Technology*, 1970.
12. Zaretsky, E.V., “STLE Life Factors for Rolling Bearings,” *Society of Tribologists and Lubrication Engineers*, Park Ridge, IL, 1992.
13. Townsend, D. and J. Shimski. “Evaluation of Advanced Lubricants for Aircraft Applications Using Gear Surface Fatigue Tests,” NASA TM-104336, 1991.

# Unlocking the Vault

We recently sent a team of *Gear Technology* editors into the tunnels and vaults under Randall Publications to find every back issue of *Gear Technology* magazine and make them available online.

This user-friendly archive, enhanced by our optimized search engine, allows subscribers to locate specific articles on topics like gear design, spiral bevel gears, inspection, cutting tools and more.

They're simply a keyword away.

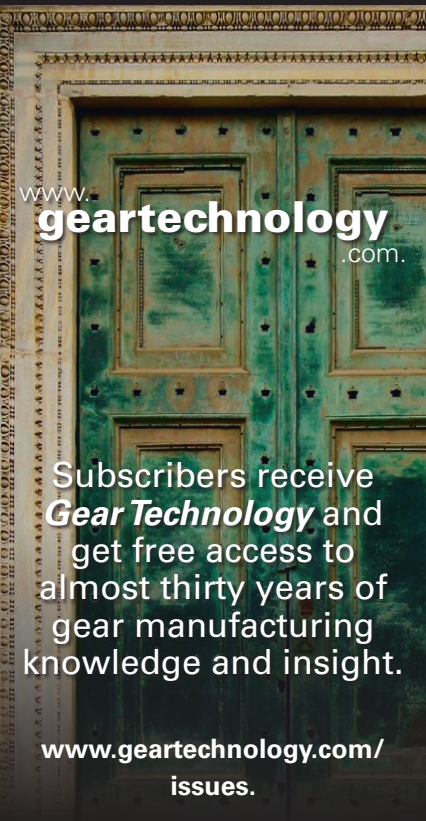

Subscribers receive *Gear Technology* and get free access to almost thirty years of gear manufacturing knowledge and insight.

[www.geartechnology.com/issues](http://www.geartechnology.com/issues)

14. Townsend, D. and J. Shimski. "Evaluation of the EHL Film Thickness and Extreme Pressure Additives on Gear Surface Fatigue Life," NASA TM-106663, 1994.
15. Tanaka, S., A. Ishibashi and S. Ezoe. "Appreciable Increases in Surface Durability of Gear Pairs with Mirror-Like Finish," ASME Pub. 84-DET-223, ASME, New York, NY, 1984.
16. Ishibashi, A., S. Ezoe and S. Tanaka. "Mirror Finishing of Tooth Surfaces Using a Trial Gear Grinder with Cubic-Born-Nitride Wheel," ASME Pub. 84-DET-153, ASME, New York, NY, 1984.
17. Nakatsuji, T., A. Mori and Y. Shimotsuma. "Pitting Durability of Electrolytically Polished Medium Carbon Steel Gears," *Tribology Trans.*, 38 (2), 223-232, 1995.
18. Nakatsuji, T. and A. Mori. "Pitting Durability of Electrolytically Polished Medium Carbon Steel Gears: Succeeding Report," *Tribology Trans.*, 42 (2), pp. 393-400, 1999.
19. Hoyashita, S., M. Hashimoto and K. Seto. "Basic Studies on Fatigue Strength of Case-Hardened Gear Steel - Effects of Shot Peening and/or Barreling Processes," AGMA 98FTM3.
20. Hashimoto, M., S. Hoyashita and J. Iwata. "Studies on Improvement of Surface Durability of Case-Carburized Steel Gears: Effects of Surface Finish Processes Upon Oil Film Formation," AGMA 98FTM9.
21. Krantz, T.L., M.P. Alanou, H.P. Evans and R.W. Snidle. "Surface Fatigue Lives of Case-Carburized Gears with an Improved Surface Finish," *Journal of Tribology* 123, No. 4, 2001.
22. Krantz, T. "The Influence of Roughness on Gear Surface Fatigue," Ph.D. Thesis, Case Western Reserve University, Cleveland, Ohio, USA, 2002.
23. Niskanen, P.W., A. Manesh and R. Morgan. "Reducing Wear with Superfinish Technology," *AMPTIAC Quarterly*, Vol. 7, No. 1, 2003.
24. Townsend, D.P., J.L. Chevalier and E. V. Zaretsky. "Pitting Fatigue Characteristics of AISI M-50 and Super Nitralloy Spur Gears," NASA TN D-7261, 1973.
25. Rebbeschi, B., F. Oswald and D. Townsend. "Dynamic Measurements of Gear Tooth Friction and Load," NASA-TM-103281, AVSCOM-TR-90-C-023, 1990.
26. AGMA 2000-A88. *Gear Classification and Inspection Handbook: Tolerances and Measuring Methods for Unassembled Spur and Helical Gears (Including Metric Equivalents)*, AGMA, 1988.
27. Snidle, R., H. Evans and M. Alanou. "The Effect of Superfinishing on Gear Tooth Profile," AD-A327916, Defense Technical Information Center, Ft. Belvoir, VA, 1997.
28. Moyer, C.A. and L.L. Bahney. "Modifying the Lambda Ratio to Functional Line Contacts," *STLE Trib. Trans.* Vol. 33 (No. 4), pp. 535-542, 1990.
29. AGMA 925-A03. "Effect of Lubrication on Gear Surface Distress," AGMA, 2003.
30. Thomas, T.R. "Characterization of Surface Roughness," *Precision Engineering*, No. 3, Vol. 2, 1981.
31. Hamrock, B. and D. Dowson. *Ball Bearing Lubrication*, John Wiley and Sons, New York, 1981.
32. Johnson, L. *The Statistical Treatment of Fatigue Experiments*, Elsevier, New York, 1964.
33. Townsend, D.P., J.J. Coy and E.V. Zaretsky. "Experimental and Analytical Load-Life Relation for AISI 9310 Steel Spur Gears," *Journal of Mechanical Design*, Vol. 100, No.1, 1978.
34. Skurka, J.C. "Elastohydrodynamic Lubrication of Roller Bearings: Effects of Endurance Life on Film Thickness and Surface Finish," ASME 69-LUB-18, 1969.
35. Anderson, W.J. "Elastohydrodynamic Lubrication Theory as a Design Parameter for Rolling Element Bearings," ASME 70-DE-19, *ASME Design Engineering Conference and Show*, 1970.



**Tim Krantz** has since 1987 worked as a research engineer at the NASA Glenn Research Center—first as an employee of the U.S. Army and presently as an employee of NASA. He has researched many topics to improve power transmission components and systems, with an emphasis on helicopter gearbox technologies. He has also helped investigate several issues for the NASA Engineering Safety Center—including the space shuttle rudder speed brake actuator, space shuttle body flap actuator and the International Space Station solar alpha rotary joint mechanisms. Krantz is the current vice-chair of the ASME Power Transmission and Gearing Committee.

