

Back To Basics

Manufacturing of Forged and Extruded Gears

David J. Kuhlmann

P.S. Raghupathi

Battelle Columbus Division, Columbus, OH

Introduction

Traditional methods of manufacturing precision gears usually employ either hobbing or shaper cutting. Both of these processes rely upon generating the conjugate tooth form by moving the workpiece in a precise relation to the tool. Recently, attention has been given to forming gear teeth in a single step. Advantages to such a process include reduced production time, material savings, and improved performance characteristics. Drawbacks include complicated tool designs, non-uniformity of gears produced throughout the life of the tooling, and lengthy development times.

Through projects funded by the U.S. Army Tank Automotive Command, Battelle's Columbus Division developed a method for designing spiral bevel, spur, and helical gear forming dies. This article discusses this method and summarizes the current state of the art regarding the manufacturing of forged and extruded gears.

Traditional Gear Forming Methodology

Design/test/modify. The traditional method of forging and extrusion die design and manufacture is based on exper-

ience and trial and error. A preliminary die is made, and a few parts are formed. Measurements are taken of the finished part, and the die is modified accordingly. A second series of trials is conducted, and so on, until the final die geometry is obtained. Such a develop-

ment program is required for every new design, which makes the precision forming process economically less attractive, especially when complex and precise geometries are involved, as with gears. Therefore, methods need to be developed to apply advanced computer-aided design and manufacturing (CAD/CAM) technologies (analysis of loads, stresses, and temperatures using finite element method based approaches, etc.) to gear forming die design and manufacture. This approach benefits from the capabilities of the computer in performing complex mathematical analysis and information storage, and allows the die designer to examine the effects of various changes of process variables on the die design, without trying out each new change on the shop floor.

CAD/CAM Applied To Forging and Extrusion

In recent years, CAD/CAM techniques have been applied to various forging processes. The experience gained in all of these applications implies a certain overall methodology for CAD/CAM of dies for precision and/or near-net shape forming. This computerized approach is also applicable to precision cold and hot forming of spiral bevel,

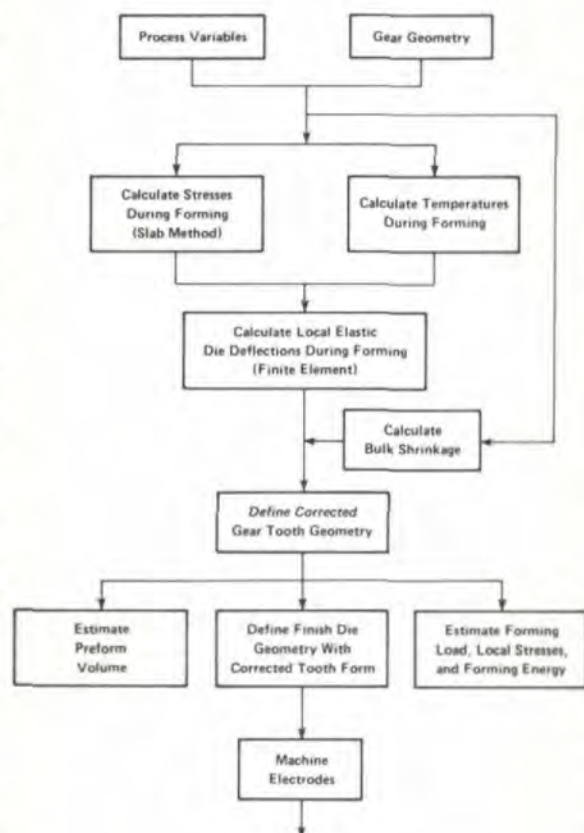

Fig. 1—Methodology for designing gear forming dies.

spur, and helical gears, as seen in Fig. 1. The procedure uses as input: the process variables and the part (gear) geometry. The former consist of:

(1) data on billet material under forming conditions (billet and die properties, such as flow stress as a function of strain, strain-rate, temperatures, and heat transfer coefficients),

(2) the friction coefficient to quantify the friction shear stress at the material and die interface, and

(3) forming conditions, such as temperatures, deformation rates, and suggested number of forming operations.

Using the process variables and the part geometry, a preliminary design of the finish forming die can be made. Next, stresses necessary to finish form the part and temperatures in the material and the dies are calculated. The elastic die deflections due to temperatures and stresses can be estimated and used to predict the small corrections necessary on the finish die geometry. Knowledge of the forming stresses also allows the prediction of forming load and energy. The estimation of die geometry corrections is necessary for obtaining close tolerance formed parts and for machining the finish dies to exact dimensions. The corrected finish die geometry is used to estimate the necessary volume, and the volume distribution in the billet or the preform. Ideally, a simulation of the metal flow should be conducted for each die design. This is a computerized prediction of metal flow at each instant during forming. This simulation allows the determination of the cavity filling without excessive loading of the dies and prediction of defects.

Process Variables

Billet Material Characterization.⁽¹⁾

For a given material composition and deformation/heat treatment history (microstructure), the flow stress, and the workability (or formability) in various directions (anisotropy), are the most important material variables in

analysis of a metal forming process. For a given microstructure, the flow stress, σ , is expressed as a function of strain, ϵ , strain rate, $\dot{\epsilon}$, and temperature, T :

$$\sigma = f(\epsilon, \dot{\epsilon}, T) \quad (1)$$

To formulate the constitutive equation (Equation 1) it is necessary to conduct torsion, plane-strain compression, and uniform axisymmetric-compression tests. During any one of these tests, plastic work creates a certain increase in temperature of the billet material, which must be considered in evaluation and use of the test results.

Tooling and Equipment. The selection of a machine for a given process is influenced by the time, accuracy, and load/energy characteristics of that machine. Optimum equipment selection requires consideration of the entire forming system, including lot size, conditions at the plant, environmental effects, and maintenance requirements, as well as the requirements of the specific part and process under consideration.

The tooling variables include design and geometry, surface finish, stiffness and mechanical and thermal properties under conditions of use.

Friction and Lubrication at the Tool/Workpiece Interface. The mechanics of interface friction are very complex. One way of expressing friction quantitatively is through a friction coefficient, μ , or a friction shear factor, m . Thus, the frictional shear stress, τ , is

$$\tau = \sigma_n \cdot \mu \quad (2)$$

or

$$\tau = m \cdot \sigma \sqrt{3} = f \cdot \sigma \quad (3)$$

where σ_n is the normal stress at the interface, σ is the flow stress of the deforming material, and f is the friction factor.

Friction estimation. The friction between the workpiece and the tooling is dependant upon the die surface, the temperature, and the type of lubricant. A standard test, called the ring test, is

used to determine the friction shear factors of various lubricants. This test involves taking a ring of known dimensions and temperature and upsetting it (thickness reduction) between flat dies. Measurement of the final inside and outside diameters plus thickness enable one to calculate the friction shear factor of the lubricant. Thus, to accurately predict the loads when forming gears, it is important that data be obtained regarding the friction associated with the lubricant to be used.

Estimation of Die Corrections. Temperature Effects. Temperature affects all forgings in two ways. First, when the workpiece is heated to be able to form the part, it expands. In addition, the material will always increase in temperature due to deformation heating. After the part is formed, it shrinks during cooling. Thus, the final part size will always be smaller than the die in which it was formed. The second temperature effect comes from the tooling. The tooling will always be slightly heated due to the transfer of heat from the workpiece. In addition, the die may be intentionally heated if the part is to be formed at elevated temperatures. This prevents premature tool failure or defect formation in the final part. As a result, the part formed will always be larger than the size of the die manufactured at "room temperature". Both of



AUTHOR:

DAVID J. KUHLMANN, is manager of the Net Shape Manufacturing Section of Battelle Columbus Division. For the past seven years he has been developing interactive, graphics-oriented computer programs for metal forming processes and has authored several papers.

DR. P.S. RAGHUPATHI, formerly with Battelle Columbus Division, is an expert in the area of cold extrusion, closed die forging, deep drawing, metal forming machine tools, and computer aided design and manufacturing. In addition to being the author/co-author of more than 30 publications, he is also a co-editor of the Metal Forming Handbook (Springer-Verlag, 1985).

these temperature effects must be compensated for when designing tooling which one expects to use to form near-net parts.

Shrink fitting. Shrink fitting refers to the technique of placing the forming die, which contains the cavity in which the part is formed, under a residual compressive stress to permit higher forming loads. This compressive stress is generated by using an interference between the die and one or more outer rings. As a result of this shrink fitting, the dimensions of the die cavity will be smaller than when it was machined. This dimensional shrinkage must also be accounted for when designing the forming dies for near-net shape manufacturing.

Elastic Deflection. (Mechanics of Plastic Deformation/Slab Method). During forming, pressure on the workpiece causes the die to expand, and the material moves out to meet this expanded surface. To compensate for this geometry change, the die must be corrected, depending on the estimated pressure. To calculate this pressure, an elementary plasticity theory developed by Sachs⁽²⁾ and Siebel⁽³⁾, known as slab theory, can be applied to practical metal forming problems. The following reasonable assumptions are made⁽¹⁾:

- The deforming material is isotropic and incompressible.
- The elastic deformations of the deforming material and of the tool are neglected.
- The inertial forces are small and are neglected.
- The friction shear stress is constant at the die/material interface and is defined as in Equation 3 above.
- The material flow criterion is defined by TRESCA's maximum shear stress criterion:

$$\sigma_1 - \sigma_3 = \sigma \quad (4)$$

where σ_1 and σ_3 are the maximum and minimum principal stresses respectively.

- The flow stress, σ , and the temperature are constant within the analyzed portion of the deforming material.

The basic approach for using the slab method is as follows:

1. The region of material undergoing plastic deformation is identified. Thus, the boundary between the elastic and plastic regions of the workpiece material is identified.
2. One of the three principal stresses (assuming TRESCA's yield condition will be used) should be determined. In most cases it will be easy to determine certain points where one of the principal stresses must be zero. For example, on a simple forward extrusion process, the axial stress should be zero at the exit of the die. It will also be necessary to determine the nature of this stress in the deformation zone (tensile or compressive).
3. In order to apply the TRESCA yield criterion, the maximum and minimum principal stresses must be ascertained.
4. The equilibrium equations of stresses in the deformation zone are then formulated assuming the deformation zone is completely filled. Knowing the friction and flow stress of the material in the deformation zone, the load required for the operation can be computed.

Case 1: Extrusion. Fig. 2 shows the basic arrangement of the tooling for extruding a spur or helical gear, as well as the friction forces present.

The force required to extrude the gear is given by:

$$F_p = F_{id} + F_{sh} + F_f \quad (5)$$

where:

F_p = total punch force,

F_{id} = ideal deformation force,

F_{sh} = force due to shearing of the material at the entry and exit of the die, and

F_f = friction force along the die walls and the punch.

The friction force, F_f , is equal to the sum of the friction forces shown in Fig. 2. The remaining forces, F_{id} and F_{sh} , are computed from measurements of the flow stress of the material being formed. Once the total punch force is calculated, the punch pressure, as well as the radial pressure in the die cavity, can be determined. This last parameter is required in order to determine and compensate for die deflections.

Case 2: Forging. A typical tool setup for forging spur or helical gears is given in Fig. 3. In this case, the slab method is applied in similar fashion to extrusion, except that in this case, each tooth can be thought of as being extruded individually, and the total force calculated by multiplying by the number of teeth in the gear. The procedure for computation of loads for forging spiral bevel gears is also similar. (Fig. 4.)

Generating the Gear Tooth Geometry

To define the tooth geometry, certain gear and/or cutting tool parameters must be specified. Some additional data pertaining to the mating gear may also be required in certain instances. All the

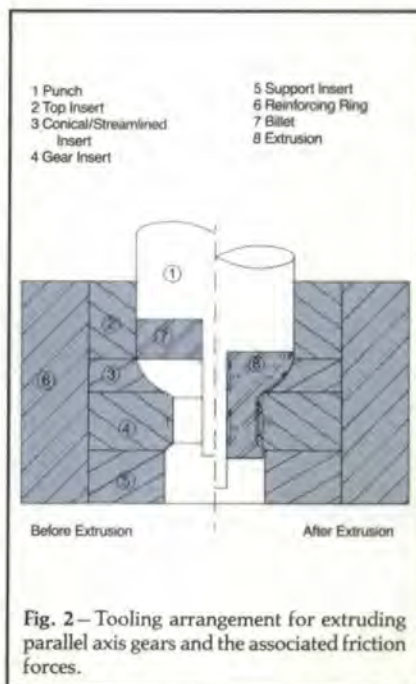

Fig. 2—Tooling arrangement for extruding parallel axis gears and the associated friction forces.

data required for the computations and the geometry of the cutting tool can be obtained from a "summary sheet" developed by gear designers. With this data, standard gear equations are used to calculate the X and Y coordinates of the points describing the gear tooth profile.

Cutting the Die. A common method of die manufacture is called Electrical

Discharge Machining (EDM). The process uses an electrode, usually made of graphite or brass, which is the negative of the die geometry. The electrode is brought close to, but not in contact with, the die material. An electrical current is allowed to arc across the gap which "burns" away the die material. Another form of this method of manufacture is called wire EDM. Current is

passed through a straight wire that moves in two dimensions, burning the die geometry as it moves. Spur and straight bevel gear dies are the only ones which can be cut using the wire EDM process. In all cases, a corrected set of gear tooth profile coordinates is needed. Under contract from the United States Army Tank-Automotive Command, Battelle Columbus Division engineers developed two computer programs which calculate corrected gear tooth geometries and assist in the overall die design process. These programs, called SPBEVL and GEARDI, are used for spiral bevel gear forging and spur/helical gear extrusion/forging respectively.

Computer Program "GEARDI". The main functions of GEARDI are

- Define the exact tooth form of a spur or helical gear,
- Compute the forming load required to produce the current gear design,
- Compute the coordinates of the corrected gear geometry necessary for machining the EDM electrodes by taking into account the change in the die geometry due to temperature differentials, load stresses, and shrink fitting, and,
- Determine the specifications of a tool which can cut the altered tooth geometry on a conventional hobbing or shaper cutter machine.

This program enables the user to design spur and helical gears, predict tooling loads and pressures, estimate metal flow for forming the gear, and define the geometry required to manufacture the tooling using conventional or wire EDM. Several examples of gears currently being forged in industry were tested in the GEARDI computer program. The predicted forging loads were within acceptable limits of the actual loads measured during production runs.

GEARDI is an interactive, graphics-oriented program which was developed on a Digital Equipment Corporation

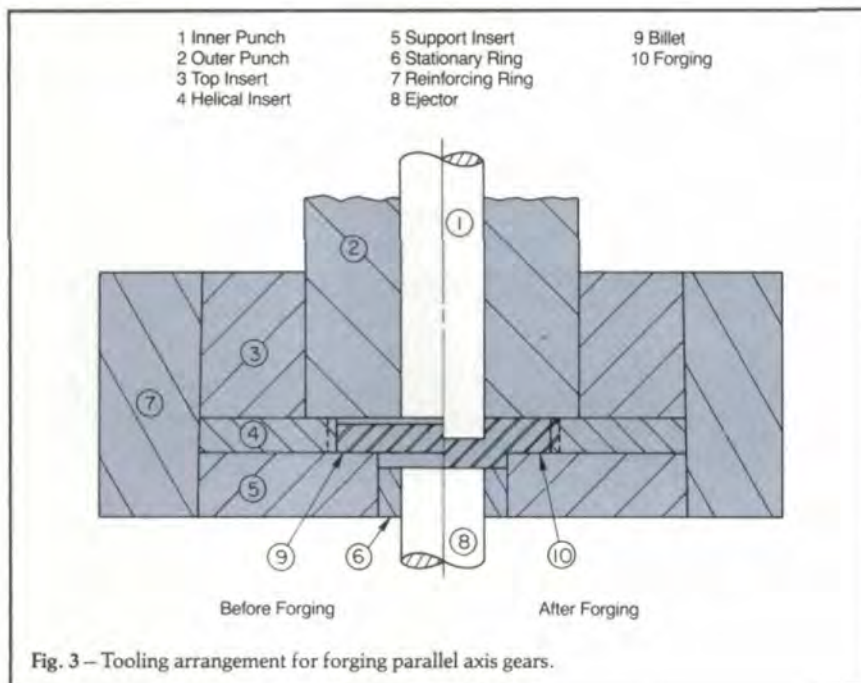

Fig. 3 - Tooling arrangement for forging parallel axis gears.

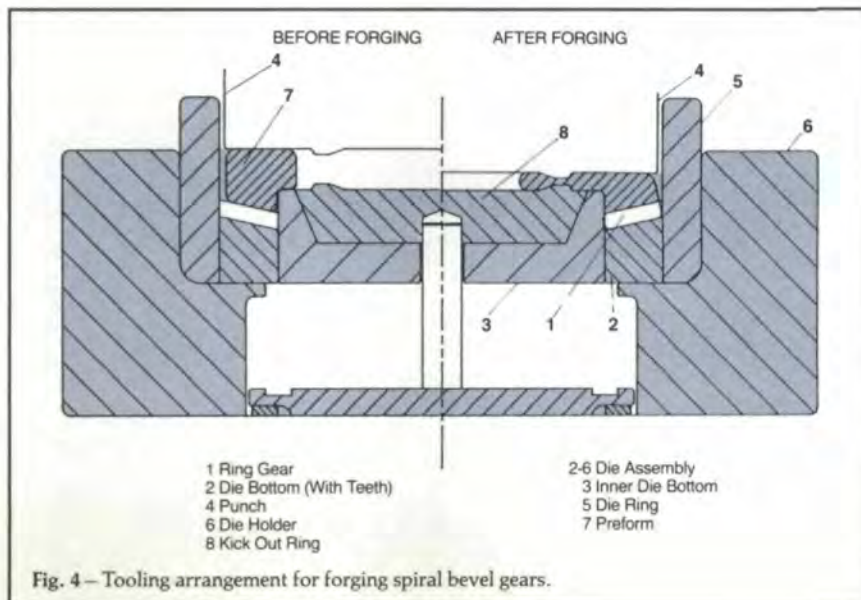

Fig. 4 - Tooling arrangement for forging spiral bevel gears.

VAX/ VMS 11/750 computer. It is a menu-driven program that allows the user to select various options from a pre-defined list. The GEARDI program has powerful application possibilities, not only in the area of metal forming, but also in the area of gear and gear train design, with its ability to design hobs and shaper cutters and to modify the fillet from a trochoidal shape to a circular shape.

Computer Program "SPBEVL". The main functions of the computer program "SPBEVL" are

- Determine the tooth geometry for spiral bevel gears and pinions normally machined on Gleason generators. The full implementation in the program is for FORMATE™ gears only. This is accomplished by an analysis of the kinematics of the machine, blank and cutter dimensions, and initial settings proposed from the Gleason summary charts.
- Correct the tooth geometry for the forging process parameters, such as temperature of forging, initial die temperatures, etc. The corrections are made for temperature differentials, loading of the dies, die manufacturing techniques (electrode overburn, shrink-fitting, etc.)
- Give new machine settings, blank, and tool geometries determined from the modified tooth geometry. These are used to machine the EDM graphite electrodes on the same Gleason machines that are used to cut the gears.

SPBEVL is an interactive graphics program operational on VAX/ VMS systems.

Extrusion Trials

Spur/Helical Gears. Tooling designed using the GEARDI program was used to conduct spur and helical gear extrusion trials at Battelle's Columbus Division using a 700-ton hydraulic press. These trials were intended to validate the capabilities of the GEARDI program and demonstrate the prac-

ticality of extruding parallel axis gears. The spur gear was a 15 tooth, 5 DP gear. The gears were extruded using a "push-through" concept. Each gear is first partially formed and left in the die while the punch is retracted. A second billet is placed on top of the partially formed gear and the press is cycled again. During this cycle, the partially formed gear is finished formed and pushed through the die, dropping out the bottom of the die. Fig. 5 shows the sequence of parts in the tooling. Once formed, the teeth on the gear are not machined further. A fixture which holds the gear on the pitch line of the teeth is used to finish-machine the inside and ends of the gear. The spur gear

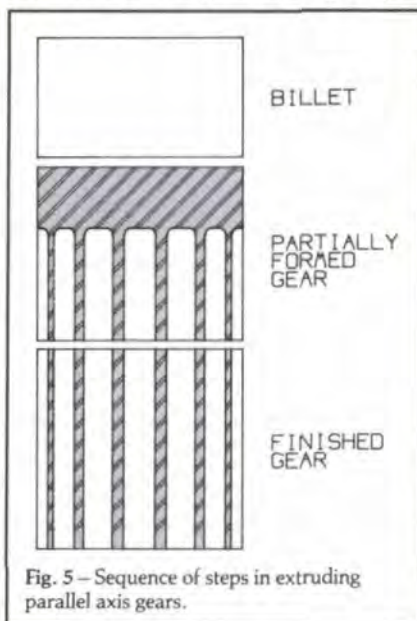

Fig. 5 - Sequence of steps in extruding parallel axis gears.

formed in these trials is intended to be an AGMA quality class 8 gear. Measurements taken on the extruded gears indicated a gear of between AGMA quality 7 and 8.

The helical gear chosen for the extrusion trials was a 32 tooth 10 DP gear with a helix angle of 30°. During the forming trials, several dies were damaged from internal tooth breakage. This was due largely to the relatively high helix angle and the fine pitch of the part. Several die designs were used before parts were finally extruded successfully. Yet even these gears were observed to have poor surface finish and were less accurate than desired.

Spiral Bevel Gear. Refer to Fig. 4 for a schematic of some initial forging tooling. The preform geometry is given in Fig. 6. Hot work steel H-13 was used as the die material. Six electrodes were needed for the spark erosion of the die. The gear forging trials were conducted at Eaton Corporation's Forging Division in Marion, Ohio. A 3,000-ton, mechanical forging press was used for the trials, based upon a forging load estimate of 2,500 tons. The preforms were machined for these trials, though they could be made by forming methods. The preforms were heated in an induction coil that was specifically designed for this purpose. The preform was heated for 200 seconds under a protective atmosphere to the required forging temperature of 2,000°F (1,093°C). The forging loads were monitored using

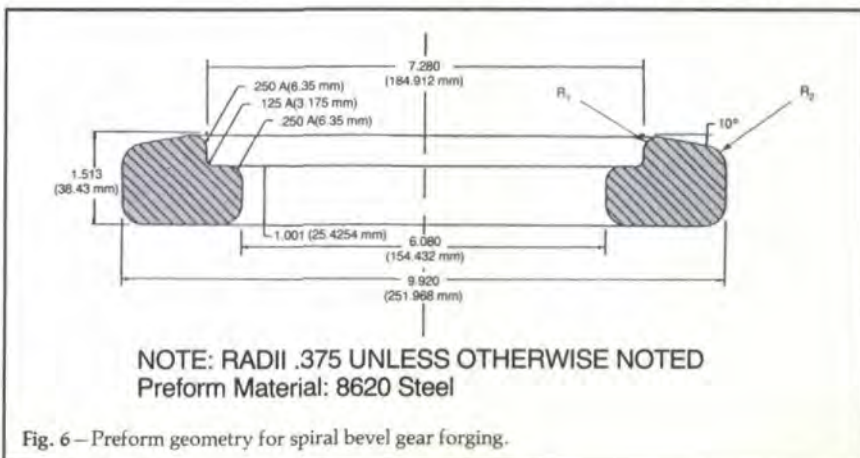
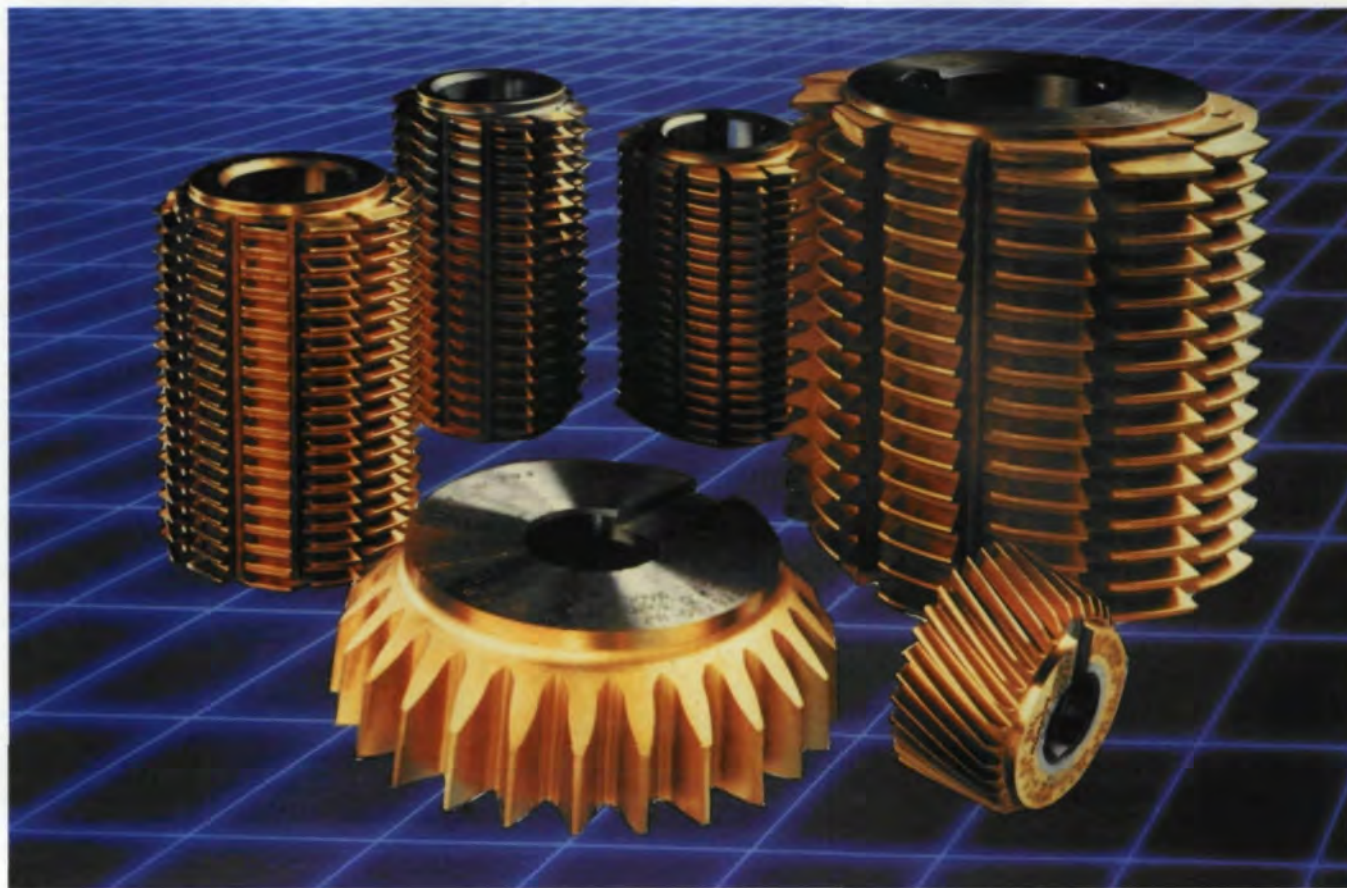

Fig. 6 - Preform geometry for spiral bevel gear forging.

For your toughest gear cutting jobs,



***the hardest steel is
the easiest choice ... CPM REX 76***

For hobs, shaper cutters and other gear cutting tools that are more than a cut above the rest, specify Crucible CPM® REX® 76. With 33% total alloy content and an attainable hardness of HRC 68-70, this high speed steel provides the highest available combination of red hardness, wear resistance and toughness, either coated or uncoated.

A Big-Three U.S. auto maker recently realized a 300% improvement in gear cutting tool life by switching from M3 HSS to CPM REX 76. With greater tool life and excellent grindability, CPM REX 76 means less downtime because resharpenering is easier and less frequent.

CPM REX 76 is just one of 10 high speed steels produced by the Crucible Particle Metallurgy process. With the industry's widest material selection, Crucible can meet your specific needs at any productivity level. You can selectively upgrade to the best CPM material for the right application.

On your next order, specify a high speed steel that's hard to beat ... CPM REX 76 or another member of the CPM REX family. To learn more, contact your nearest Crucible Service Center, or write Crucible Service Centers, 5639 West Genesee Street, Camillus, NY 13031.

** Crucible
Service Centers**

A Division of Crucible Materials Corporation

CIRCLE A-18 ON READER REPLY CARD



Bought & Sold:

- ★ BRIDLES
- ★ BELTS
- ★ BUCKLES
- ★ BOLOS
- ★ CLOTHING
- ★ CHAPS
- ★ BITS
- ★ SPURS
- ★ BOOKS
- ★ SADDLES

HIGH NOON Western Collectibles

(213) 202-9010 by appointment only
(213) 202-1340 (fax)

CIRCLE A-19 ON READER REPLY CARD

As American as...



It's true, our Consumer Information Catalog is filled with booklets that can answer the questions American consumers ask most.

To satisfy every appetite, the Consumer Information Center puts together this helpful Catalog quarterly containing more than 200 federal publications you can order. It's free, and so are almost half of the booklets it lists. Subjects like nutrition, money management, health and federal benefits help you make the right choices and decisions.

So get a slice of American opportunity. Write today for your free Catalog:



Consumer Information Center
Department AP
Pueblo, Colorado 81009

A public service of this publication and the Consumer Information Center
of the U.S. General Services Administration

load transducers attached to the frames of the press.

Die lubrication, used during the forging trials, consisted primarily of a water-base graphite material sprayed with pressurized air. After forging, the gears were placed teeth down in a sand-graphite mixture to reduce oxidation of the teeth during cooling. The back surfaces were still left exposed to the air so that the cooling rates would not be excessively slow. Gears were forged with a machining allowance of 0.007" (0.178 mm) on both tooth surfaces. A specially designed nest located the teeth so that the back surfaces are machined to be reference surfaces. This reference surface was used in the finish machining of the teeth in a conventional gear cutting machine.

The forged and machined gear was checked in a Zeiss coordinate measuring machine. Fig. 7 shows the relative deviation of the forged tooth profile as compared to a "master gear tooth" produced by conventional machining. Note that the relative error at the center of the profile is zero; i.e., the variations were measured relative to the center of the coast and drive surface of the master gear. The maximum variation was 0.003" (0.0762 mm). This difference can be easily compensated for in the machining of the pinion.

The above procedure was repeated to forge a 16" ring gear. These trials showed the applicability of the above approach in designing dies for spiral bevel gear forging.

Conclusions & Future Work

Parallel Axis Gearing. The GEARDI program has demonstrated the feasibility of extruding and forging spur and helical gears. Several U.S. gear manufacturers are currently using this program to design their dies on an ongoing basis. Still, there is much to be determined concerning the limits of this process in terms of part geometry and process conditions. Those companies which currently are forming gears using this

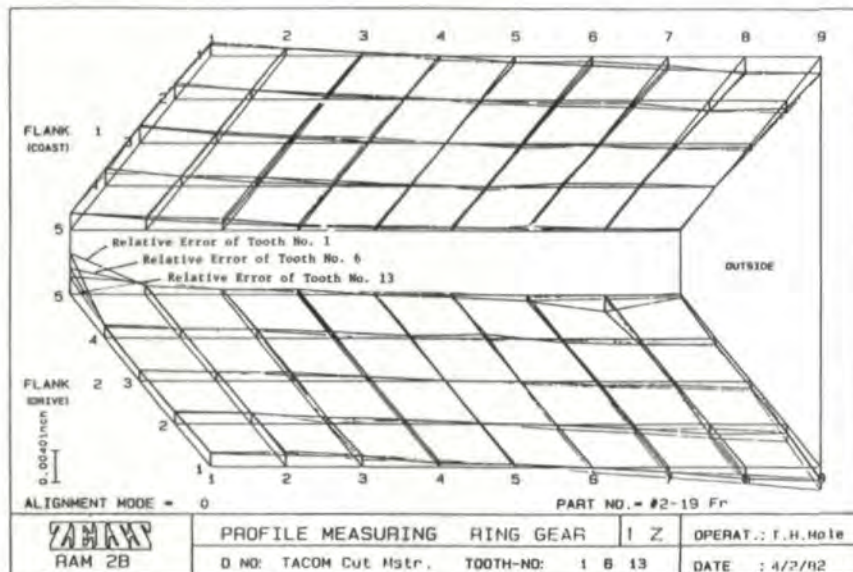

Fig. 7 - Zeiss gear tooth plots comparing the tooth form variation of a forged gear versus the cut master gear.

technology have gained considerable experience to date. There is a definite learning curve which one must travel in order to get into the business of forming gears. Research is still needed in many areas in order to generally quantify the process, including the following:

- gear materials which are formable,
- lubrication,
- tool life,
- variance in part dimensions between the first and last pieces from a given tool set, and
- limitations on part geometry.

The GEARDI program should also be improved to run on other computers, as well as refined in its ability to modify the fillet form and to more accurately estimate forming loads and generate die corrections.

Bevel Gearing. One of the major problems in spiral bevel gear forging is the extension of the above approach to other types of spiral bevel gears (generated tooth, for example). Though the modifications of the tooth surface can perhaps be determined by a rigorous mathematical treatment of the problem, the cost factor for making dies with an electrode to be machined in a five-axis machine is still unknown. Further, the computer-aided methods should con-

sider the distortion of the gear tooth during cooling. Tool life is another unknown factor. The fact that spiral bevel gears are forged around the world (with or without using the above method) is an indication that the method suggested in this article will be a good first step for the initial design of the dies without much trial and error. The future work is currently directed towards extending the above concept to gears that are cut with both modified roll and tilt mechanisms using Gleason machines.

References:

1. ALTAN, T., OH, S., and GEGEL, H. *Metal Forming Fundamentals and Applications*, ASM, Metals Park, Ohio, 1983, pp. 6-8, 132.
2. SACHS, G. "On the Theory of the Drawing Process". (in German), *Z. angew. Math. u. Mech.*, 7, 1927, pp. 235-236.
3. SIEBEL, E. *Metal Forming in Plastic Condition* (in German), Düsseldorf, Verlag Stahleisen, 1932.

Acknowledgements: Reprinted with permission of the American Gear Manufacturers Association. The opinions, statements, and conclusions presented in this paper are those of the authors and in no way represent the position or opinion of AGMA.

Special thanks to William L. Janninck for his help with the technical editing of this article.

SEPTEMBER 5-13, 1990.
IMTS-90, McCormick Place, Chicago, IL. Largest trade show in the Western hemisphere with exhibitors from around the world. A new feature this year will be the 120,000 sq. ft. Forming and Fabricating Pavilion. For more information, contact: IMTS-90, 7901 Westpark Drive, McLean, VA 22102-4269. Ph: (703) 893-2900. Fax: (703) 898-1151.

SEPTEMBER 11-13, 1990.
Short Course on Gear Noise. The Ohio State University, Columbus, OH. Discussions will cover gear noise cause and reduction, measurement and analysis, transmission error methods, dynamic modeling, gear noise signal analysis, and shaft and housing dynamics. Case history workshops and laboratory demonstrations. Featured speakers include Profs. D. R. Houser and R. Singh of OSU and Dr. Robert Munro of Huddersfield Institute of Technology, England. For more information contact: Mr. Richard D. Frasher, Director, Continuing Education, College of Engineering, 2070 Neil Ave., Columbus, OH 43210. (614) 292-8143.

OCTOBER 29-31, 1990.
AGMA Fall Technical Meeting. Hilton International Hotel, Toronto, Canada. Papers and seminars on gear design, analysis, manufacturing, applications, gear drives, and related products. Contact AGMA, 1500 King St., Suite 201, Alexandria, VA, 22314. (703) 684-0211.