

# Alternative Lubrication Methods for Large Open Gear Drives

Dennis A. Lauer, P.E.

**T**he type of lubricant and the method of applying it to the tooth flanks of large open gears is very important from the point of view of lubrication technology and maintenance. When selecting the type of lubricant and the application method, it is important to check whether it is possible to feed the required lubricant quantity to the load-carrying tooth flanks. This is necessary to avoid deficient lubrication, damage to the gear and operational malfunctions. It is important to determine the type of lubricant, which may be fluid or grease-like. The consistency of the lubricant will have a direct impact on the ability of the lubrication system to feed adequately the lubricant to the gear. The interactions between the common types of lubricant and the lubrication application methods for open gear drives are shown in Fig. 1.

Basically, there are two types of lubrication for open gear drives: Continuous lubrication (long term lubrication) and intermittent lubrication (total loss lubrication). With both these types of lubrication, several application methods are possible.

## Continuous Lubrication

Continuous lubrication means that the lubricant is fed to the friction point (the tooth meshing zone) without interruption. The lubricant volume at the load-carrying tooth flanks can vary between an extremely high and a minimal amount. Continuous lubrication may be provided by immersion lubrication, transfer lubrication with a paddle wheel or circulation lubrication.

## Immersion Lubrication

Generally, immersion lubrication is one of the safest methods of applying a lubricant to an open gear drive. To function properly the lubricant bath must remain adequately filled and the gear guard cover properly sealed to avoid lubricant losses. Modern fluids, which were especially developed for open gear drives and whose consistency and flow behavior were designed specifically for this application method, increase the efficiency of immersion lubrication considerably.

It is important to know the operational limits of these modern fluids to help avoid critical situations caused by ambient temperature extremes. The safety of the immersion lubrication system is based on the fact that either the pinion or the gear

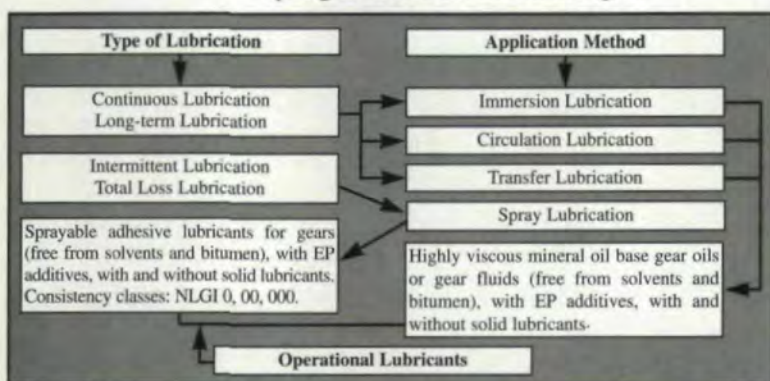

Fig. 1 — Common types of lubrication and application methods for large gear drives.

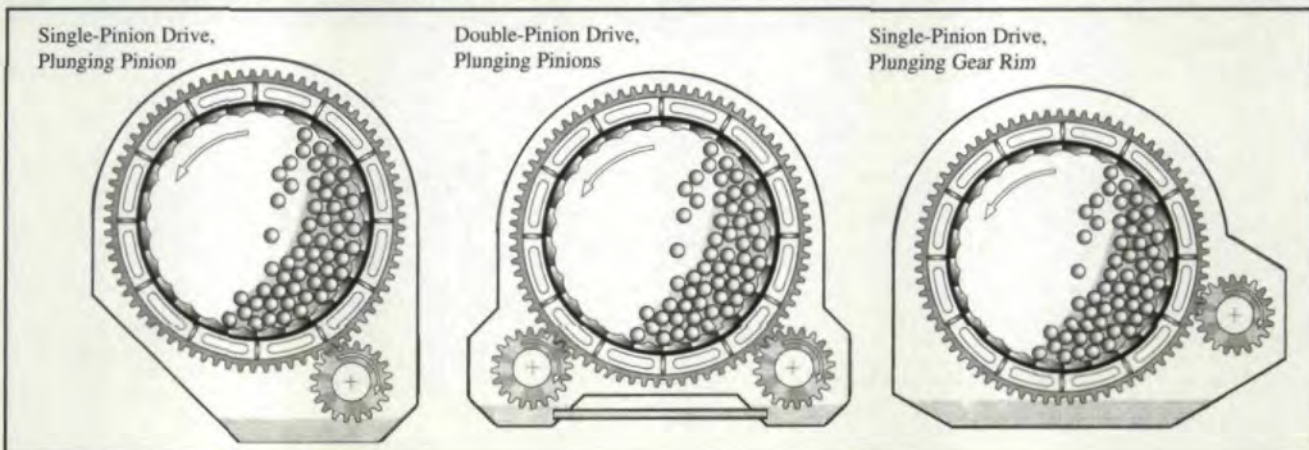

Fig. 2 — Types of immersion lubrication.



is in direct contact with the lubricant reservoir (Fig. 2). To ensure this system's reliability and prevent deficient lubrication, it is important to regularly compensate for lubricant losses from leakage or lubricant discharge through the gear rim seals. Inadequate sealing between the gear guard and the gear rim will result in dust, sand, clinker, water, etc. penetrating into the immersion bath. These contaminants will eventually reach the intermeshing gear tooth zone and result in increased abrasive wear of the tooth flanks. The immersion bath should be replaced at regular intervals to prevent damage to the tooth flanks caused by contamination.

The lubricant used in the immersion system should meet the following requirements to ensure a reliable and safe operation of the gear drives for a long period of time. It should

- be solvent-free.
- have good back flow behavior; channeling should not occur at ambient temperatures.
- have suitable viscosity/temperature behavior so that the bath must be neither heated nor cooled.
- have low evaporation losses.
- have easy replacement and disposal.
- have load-carrying capacity and antiwear behavior confirmable on the FZG gear testing rig.

#### Transfer Lubrication

In this type of lubrication, also called paddle wheel lubrication, paddle wheels plunge into the lubricant reservoir and then transfer the lubricant to the driving pinions. This method has the advantage that smaller amounts of lubricant are transferred to the tooth flanks and a smaller amount of excess lubricant is in circulation at the drive. Fig. 3 shows an example of paddle wheel lubrication of a rotary kiln with a double-pinion drive. The paddle wheels are located directly below the pinions and are driven by them. Paddle wheel lubrication is only suitable for spur-toothed gear drives and is mainly found on slowly operating kiln drives.

#### Circulation Lubrication

In circulation lubrication, the lubricant is transferred by means of externally driven pumps. The main advantage, as compared to immersion lubrication, is the fact that the lubricant is filtered and then applied in an excess amount to the tooth flanks almost without contaminants. Circulation lubrication will be successful only if the gear guard is sealed properly and the penetration of contaminants from the environment into the lubricant reservoir is prevented as much as possible. Most circulation lubrication systems used today are designed for the application of gear oils. Some systems are also suitable for applying high-viscosity

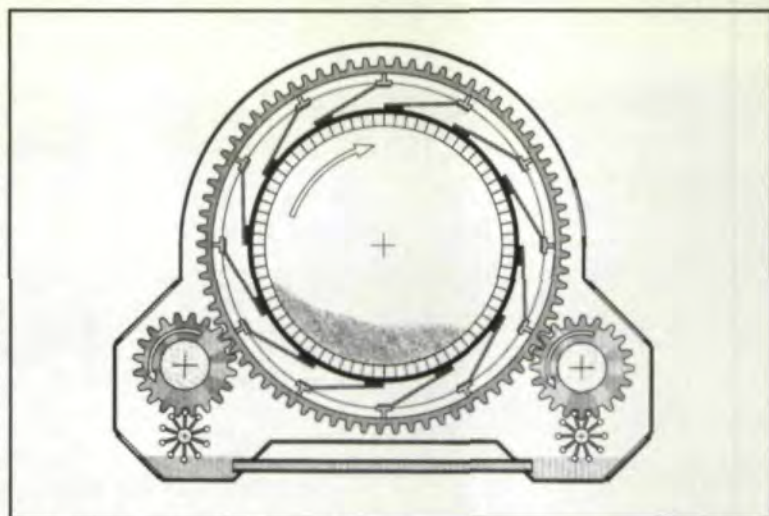

Fig. 3 — Transfer (paddle-wheel) lubrication, double-pinion kiln drive by FLS.

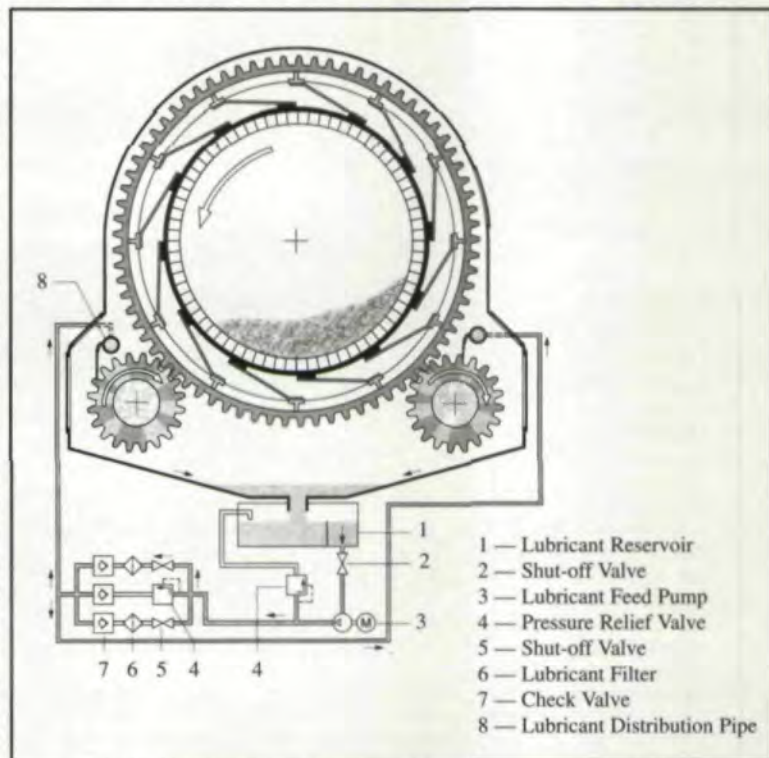

Fig. 4 — Circulation lubrication system for double-pinion drives (schematic view).

open gear fluids used in running-in lubrication, as well as operational lubrication. The typical circulation lubrication system is suitable for lubricating drives on kilns and mills and can also be retrofitted to existing installations. For large open gear drives, its main advantage is that the lubricant is continuously cleaned by filters and that it is applied to the tooth flank surfaces very efficiently through special lubricant distribution pipes. Fig. 4 is a schematic of a circulation lubrication system for a double-pinion drive.

A schematic of a circulation lubrication system with various accessories is identified in Fig. 5. From the lubricant reservoir (1.1), which is filled directly from the gear guard (4), or by means of a transfer pump (5), the lubricant is fed by gravity flow to the lubricant pump (2.1) via a

#### Dennis A. Lauer

is Vice President, Engineering at Kluber Lubrication, N.A., a lubricant manufacturer in Londonderry, NH. He is the author of numerous papers and articles on lubrication subjects.



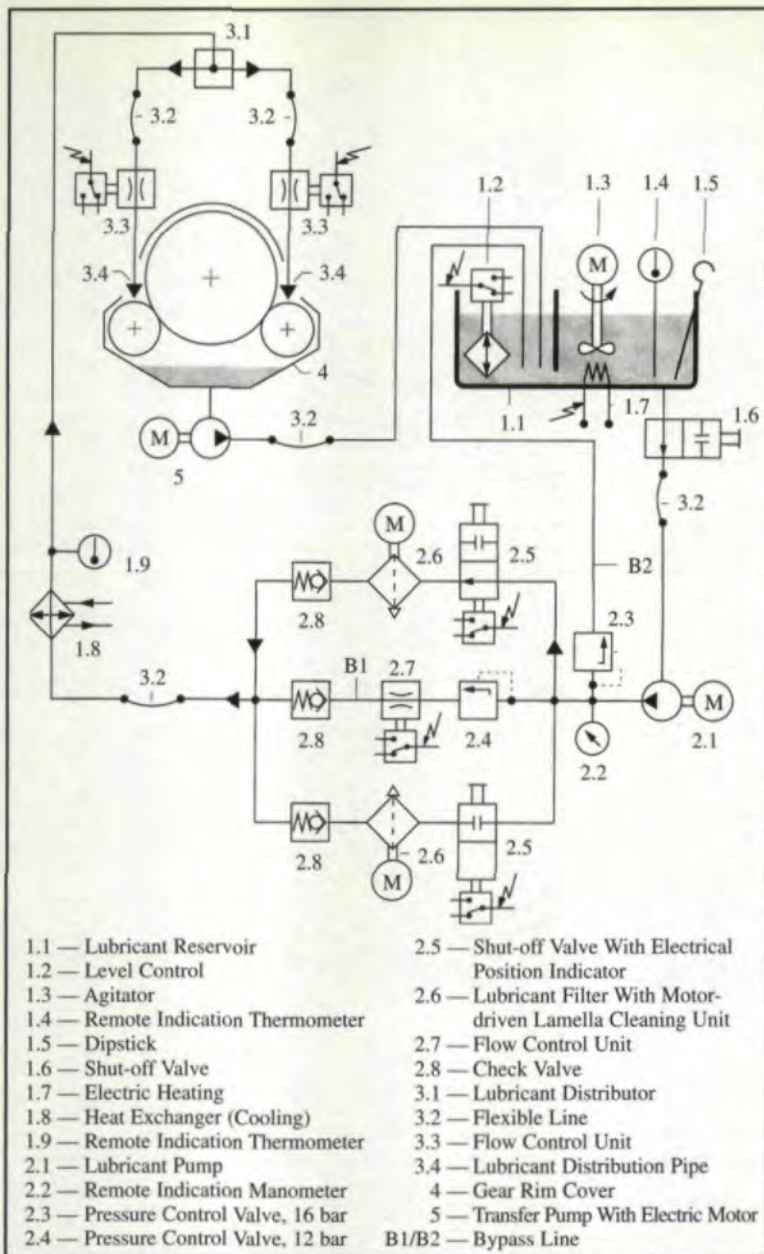

Fig. 5 — Schematic of a circulation lubrication system with various accessories.

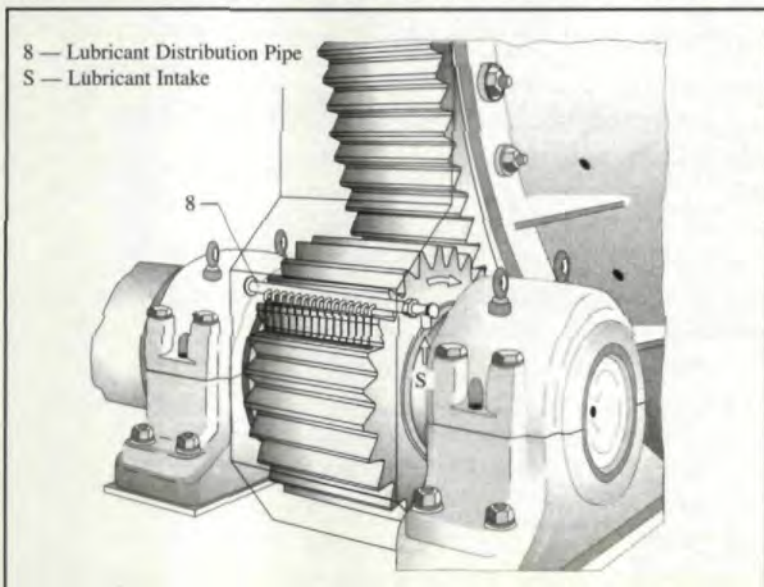

Fig. 6 — Lubricant application through specially designed lubricant distribution pipes.

pipe system. Depending on the position of the valves (2.5), it is transferred to one of the two filter units (2.6), which are equipped with a motor-driven cleaning mechanism. Since only one filter is operating at a time, the other can be maintained and cleaned without interrupting the flow of lubricant to the gears. Switching from one filter unit to the other can be accomplished manually or automatically. The recommended filter size is between 80 and 100 microns.

After passing the filter unit, the lubricant is fed through a distributor (3.1) to the distribution pipes (3.4). A check valve (2.8) prevents the lubricant from flowing backwards. If there is not enough flow through the operating filter unit (2.6), the pressure relief valve (2.4) will open. The lubricant is then supplied to the distribution pipes via the bypass line (B1). A flow control unit (2.7) installed in the bypass line will trigger an alarm, which will warn the operator to change the flow to the other filter line. The lubricant flow is then directed through the second filter unit, and the pressure relief valve (2.4) will close as soon as the pressure is reduced. The monitoring of system alarms is very important in order to prevent prolonged application of unfiltered lubricant to the tooth flanks. It is also possible to have an automatic system to control the flow direction into each filter unit based on pressure drop in the filter lines.

Flow control monitoring is also located before the distribution pipes to ensure that there is lubricant flow to the gear teeth. Fig. 6 shows the location of the lubricant distribution pipe.

If required, the lubricant reservoir (1.1) can be equipped with a heating system (1.7) and agitator (1.3). If cooling of the lubricant is necessary, a heat exchanger (1.8) can be installed in the lubricant line in front of the distribution lines (3.4). If the space available directly below the gear guard is restricted and it is not possible to install a lubricant reservoir there for a gravity flow, then a transfer pump (5) can be used.

#### Intermittent Lubrication

Intermittent lubrication means that the lubricant is applied at intervals. This type of lubrication is always total loss lubrication; therefore cost effectiveness has to be taken into account. Just as in the case of continuous lubrication; there are various methods of application of intermittent lubrication. For modern and safe lubrication of large girth gear drives, however, only two methods of application are used: Manual lubrication by spray gun and automatic spray lubrication.

#### Manual Lubrication by Spray Gun

Currently, the most effective type of manual lubrication for large gear drives is by means of



pressurized manual spray guns. They are best suited for operational lubricants in cases where stationary automatic lubrication systems cannot be installed and where lubrication is required during operation. A typical manual spray lubrication system is depicted in Fig. 7. This portable equipment consists of a pressurized lubricant container with valves, a heavy-duty spray gun and connecting hoses for the lubricant and pressurized air. This system is easy to handle and only needs to be connected to the plant air system before it can be put into operation. With the spray gun, which can be adjusted to a round or flat jet, different types of lubricants can be applied:

- Operational lubrication with very thin lubricating film and economical consumption.
- Priming of open gear drives to check the contract and load-carrying pattern.
- Lubricant application for repair correction or forced run-in lubrication.

### Automatic Spray Lubrication

Manual lubrication by means of a spray gun as described in the previous section has its limits in running-in and operational lubrication, especially when large drives have to be lubricated adequately and reliably. Automatic spray lubrication is especially suitable for gear drives that, due to their design and inefficient sealing of the gear guard, are not suitable for other types of lubricant application, and where heat dissipation by the lubricant is not necessarily required. Various manufacturers offer automatic spray lubrication systems of different designs, all of which are state of the art and are capable of handling operational lubricants with a high solid lubricant content, as well as special running-in lubricants. Ideally, the amount of lubricant sprayed onto the tooth flanks maintains a minimum thickness of lubricant film. This thickness is constantly diminished by the motion of the two flanks against each other. If the necessary film thickness is maintained, it will prevent scuffing caused by insufficient lubrication. However, this is hardly feasible for technical reasons.

It is quite obvious that during operational lubrication it is not possible to continuously apply a lubricant film of optimum thickness to the tooth flanks. A good compromise is found in interval lubrication, consisting of periods of excess lubrication. For operational reliability, the most decisive factor is the duration of the individual spraying pulse. It is best when the entire circumference of the pinion or the girth gear is sprayed and covered with lubricant in one pulse. The lubricant amounts must ensure a film thick enough to reliably last through the ensuing

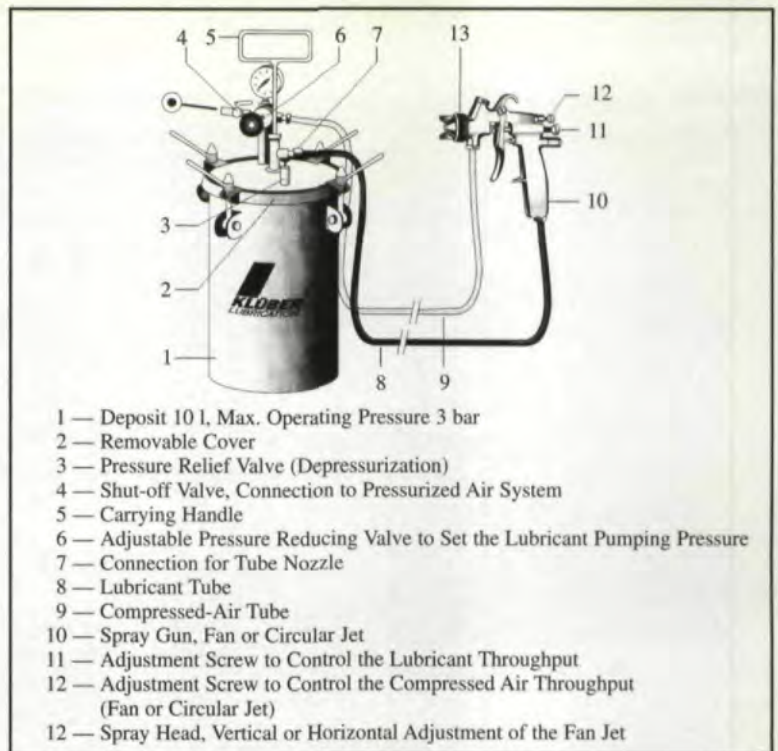

Fig. 7 — Manual spraying equipment.

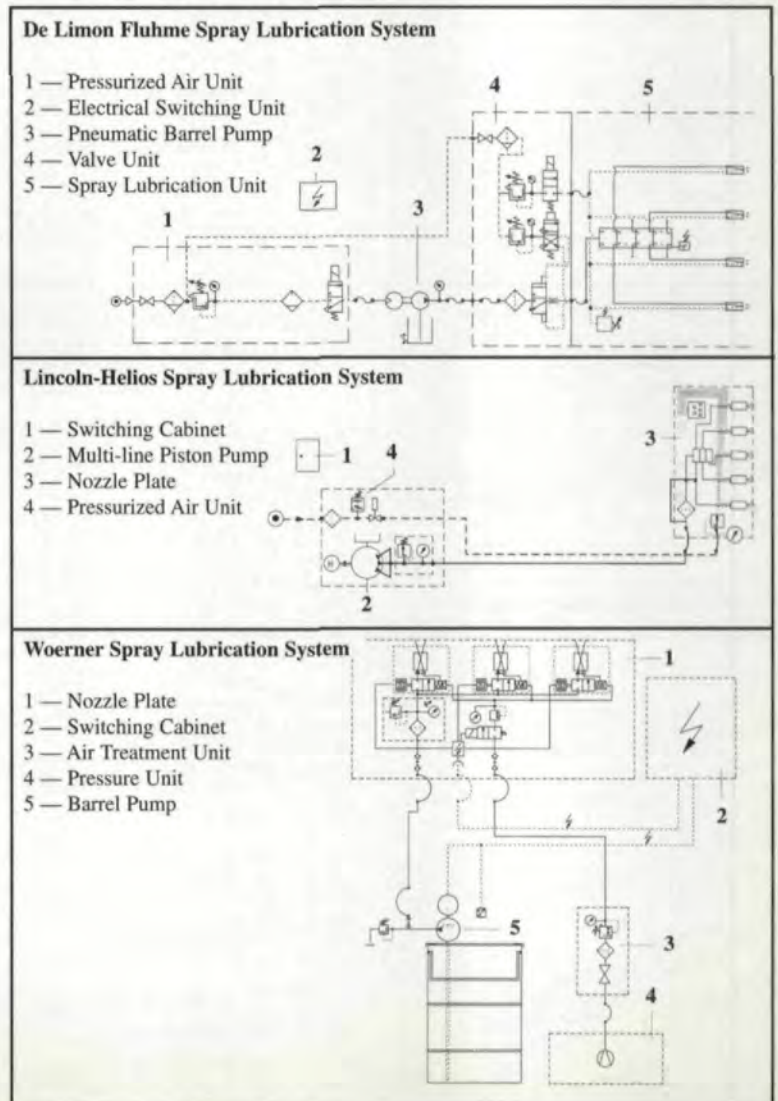

Fig. 8 — Spray lubrication systems.



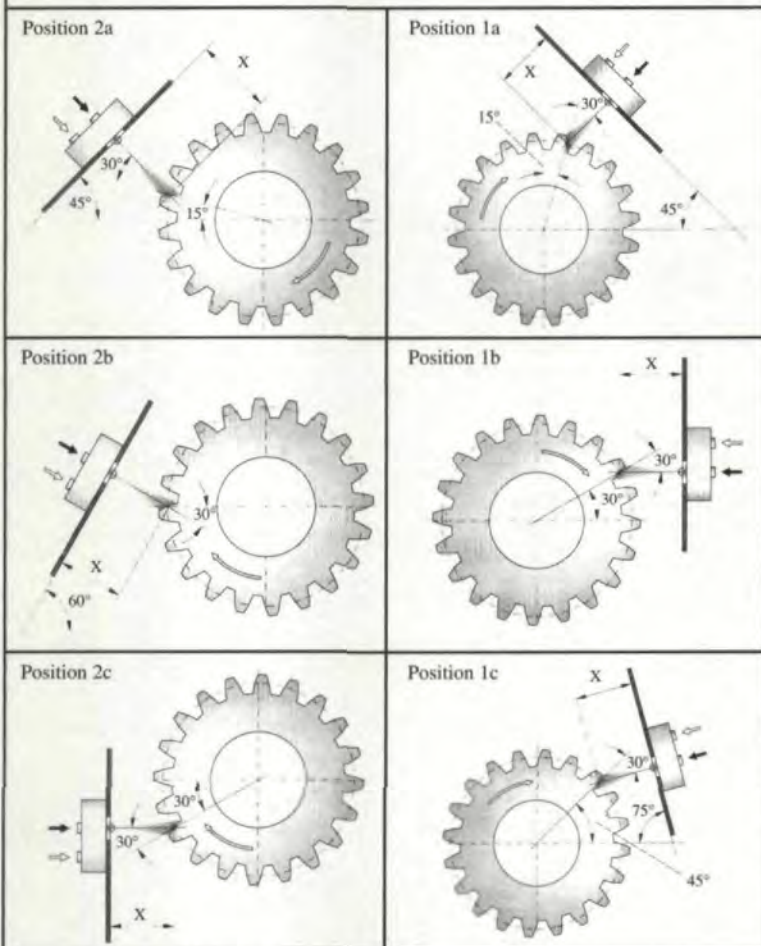
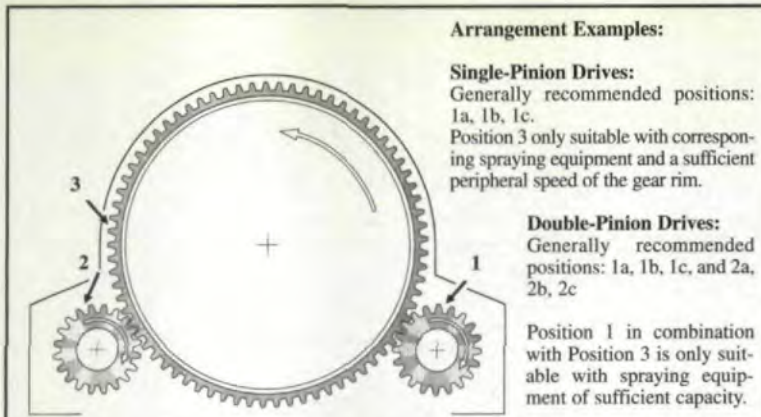

Fig. 9 — Nozzle plate arrangement.

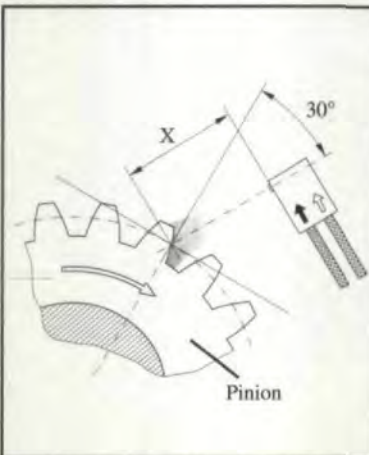

Fig. 10 — Preferable orientation of a spray nozzle.

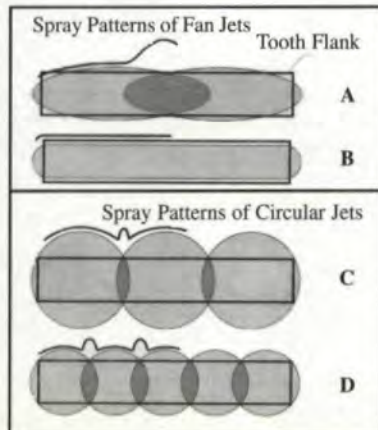

Fig. 11 — Spray patterns on gear tooth flank surface, depending on the number of nozzles and the spray geometry.

pause cycle. More frequent spray cycles with the shortest possible pauses result in the maximum operational reliability in spray lubrication.

Fig. 8 shows schematic diagrams of spray lubrication systems from different manufacturers that are used today for spraying lubricants on large girth gear drives. These systems differ in their design and components as follows:

- Lubrication pumps, e.g. electromechanical multi-line piston pumps (container pumps) with manual filling and automatic filling by means of pneumatic barrel pumps, or direct pumping by means of pneumatically or electromechanically driven drum pumps.
- Single or dual-line system design.
- Lubricant feeding to the spray nozzles either direct from the lubricant pump or via an intermediate progressive distributor.
- Auto-control spray nozzles (controlled by the lubricant and/or air) or externally controlled nozzles with or without monitoring units.

Fig. 9 shows the optimum arrangement of nozzle plates found by practical experience. Positions 1 and 2 are generally preferred. Spraying of the girth gear in position 3 should only be considered if it can be ensured that the entire circumference of the gear is covered with lubricant during one spray pulse. This applies especially to slow running kiln gears. Depending on the design of the gear guard, the nozzle plates should be arranged at the angles and positions indicated in Fig. 9. The spray nozzles should not be installed in a vertical upward direction, since they could become clogged by used lubricant. This would result in insufficient spray patterns and eventually in a complete failure of the lubricant supply system. When determining the position of the nozzles, especially when the girth gear is to be sprayed, the safety of the maintenance personnel when working on the system must be considered.

In Fig. 10, the orientation of the spray nozzle is indicated. A spraying angle of 30° is best to achieve a good distribution of the lubricant on the load-carrying tooth flanks. The nozzle distance should be between 150 and 250 mm. The exact distance depends on the position and the type of nozzle. Each type of nozzle requires a specific nozzle distance, which depends on the air pressure as determined by the manufacturer and which ensures the entire width of the tooth flank is covered with lubricant. This distance also must take into account the number of nozzles and the type of lubricant. Operational safety is reduced if the nozzles are not oriented properly.

An important factor of operational reliability is a perfect spray pattern without any gaps.



The lubricant must be distributed evenly over the entire height and width of the tooth flanks (Fig. 11). Even if the spray nozzles are automatically controlled, periodic checking of the spray pattern is an essential part of maintenance. Due to their design, older spray systems have the disadvantage that the spray pattern in high-speed drives, such as mills, can only be checked when the drive is stopped. This disadvantage can be removed by newly developed nozzle plates that make it possible to check the spray pattern while a drive is in operation.

Fig. 12 shows various nozzle plate designs. This is of special advantage on kiln drives, which cannot be stopped at random. In addition, this type of checking ensures maximum protection against accidents because it is not necessary to remove the gear guard.

Depending on the system design, the lubricant can be delivered from a container to a lubricating system by different means:

- Spray lubrication systems with container pumps (Fig. 13).
- Spray lubrication systems with drum pumps (Fig. 14).

The lubricant containers in the first system are filled manually or by means of a transfer pump out of the original package. The transfer pump is preferred because it prevents contamination of the lubricant. In the second system, the lubricant is fed directly to the spray system with the required operating pressure by means of a drum pump that is put into the original lubricant drum. Feed pumps may be driven electromechanically or pneumatically.

### Summary

The goal of the lubrication system for large gear drives is to provide the optimum amount of lubricant at all times to the gearing system. This will prevent premature wear and expensive gear replacement. All of the systems discussed can provide this goal as long as they are maintained and operated properly. The cost effectiveness of each system must be analyzed by the individual user. ☉

**Acknowledgement:** Reprinted by permission of the Society of Tribologists & Lubrications Engineers (STLE). All rights reserved.

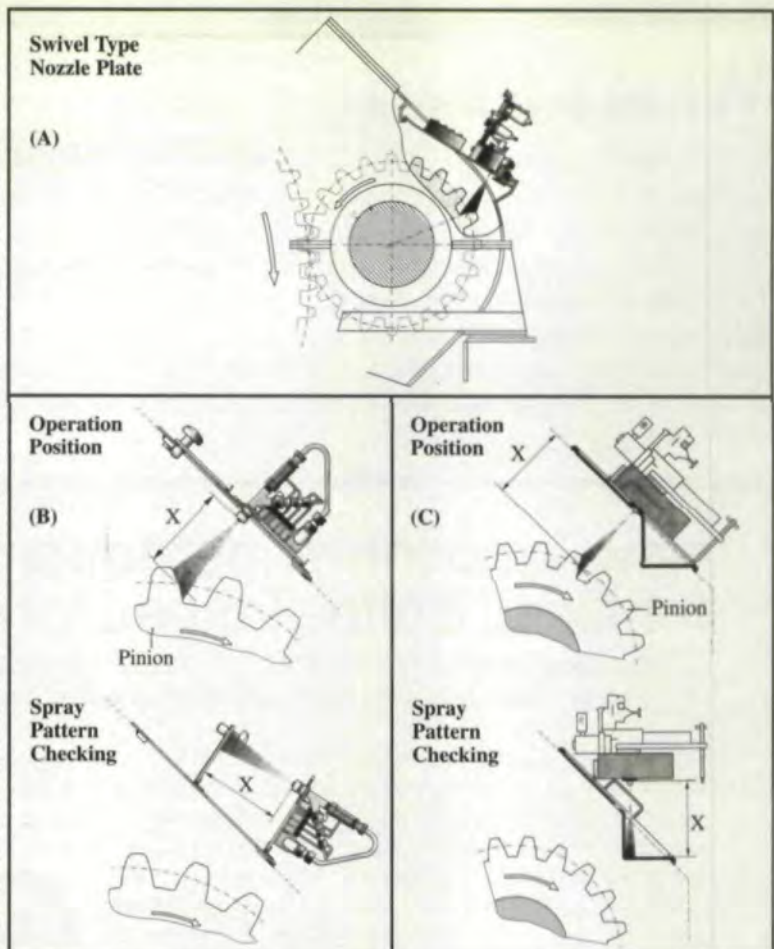

Fig. 12 — Nozzle plate systems.

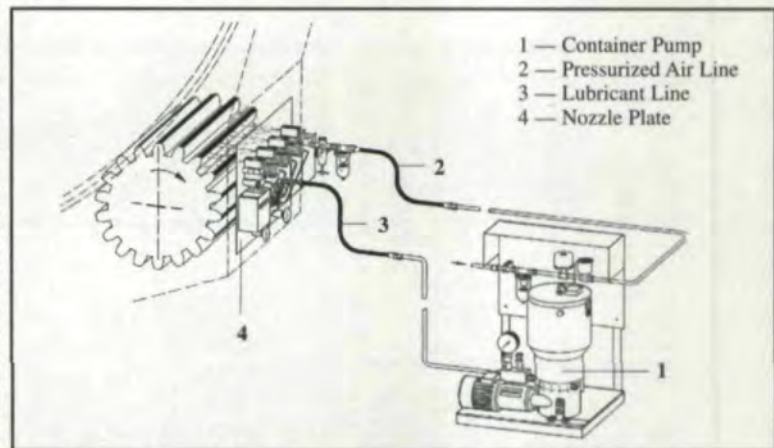

Fig. 13 — Spray lubrication system with container pump

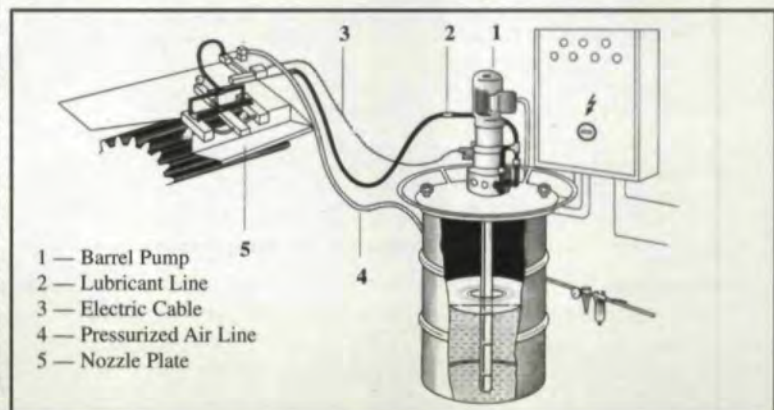

Fig. 14 — Spray lubrication system with barrel pump.

### Tell Us What You Think...

If you found this article of interest and/or useful, please circle 208.

For more information about Kluber Lubrication, N.A. please circle 209.