

# Cylkro Face Gears:

## DUTCH DESIGN AND SWISS INGENUITY CAUSE TRANSMISSION BREAKTHROUGH

When the Cylkro face gear transmission was first introduced by a Dutch company, it was met with years of skeptical disbelief and resistance from the traditional transmission establishment. Nevertheless, perseverance and a takeover in 2003 by Swiss-based ASSAG paved the way for growth and success in various industries and in many countries. This article describes the start and breakthrough of the Cylkro face gear transmission.

**Origin.** It was not until the early 1990s that face gears found some acceptance among the established transmission systems. Although face gears have been seen through history—for instance in the Chinese south-pointing chariot or in several Leonardo

da Vinci designs—these examples more often ended up as museum pieces, not fit for industrial use. Then, some 20 years ago, the University of Eindhoven (Netherlands) began researching the possibilities of calculating and manufacturing face gears in such a way that these could be used in high-end, high-torque applications.

**Design.** Derived from the Dutch words for cylindrical pinion and face gear, this new type of face gear transmission was named the Cylkro face gear. The first aim was to develop software to calculate the geometry and strength of the Cylkro transmission. A basic face gear set consists of one involute cylindrical pinion and one face gear, mostly at a 90° axis angle. It is the pinion's geometry, axial position and transmission ratio that determine Cylkro face gear geometry.

The shape of a Cylkro tooth or, more accurately, a tooth fillet, varies over its width. At the inner diameter, the fillet is relatively large as compared to the outer diameter. As a result, the point-of-contact of the Cylkro flank at the inner diameter is on a smaller radius of the pinion than at the outer diameter. Therefore, the lines of contact are inclined, even with a spur pinion. With a driving pinion, the meshing starts at the tip of the Cylkro tooth at the outer diameter (Fig. 1).

The pressure angle also varies over the tooth width, caused by higher velocity at the outer than at the inner diameter. The load capacity calculations for bending strength and pitting resistance are based upon the German standard DIN 3990 and ISO/DIS 6336, which apply to parallel gears. These include factors for geometry, meshing conditions, material properties, etc. The characteristics of the Cylkro transmission were translated into these

factors with the help of FEM calculations. In order to avoid edge contact, the teeth of the pinion and/or Cylkro gear have to be crowned. Specific Cylkro software programs allow calculating the load distribution over meshing teeth and along the lines of contact, as well as tooth root bending stress and contact stress (pitting resistance) of a Cylkro face gear transmission.

**Manufacturing.** The Cylkro face gear production method was continuously improved and is described in a large number of patents. The processes include continuous hobbing, hard-cutting and several options for surface treatments (Fig. 2).

The geometry of the hob is based on the geometry of the pinion. Because one pinion can mesh with various face gears with different numbers of teeth and axis angles, it is possible to manufacture all these types of gears with one single hob.

**Features.** The wide range of gear ratios—from 1:1 up to 20:1, and more—is only one of the Cylkro face gear's specific characteristics. Other features are:

- Axial freedom of the pinion
- Free choice of axis angle from 0° to 135°
- The possibility of helical teeth or axis offset
- Multiple power transmissions; i.e.—two or more pinions mesh with one or between two face gears

**Customer-specific applications.** Almost all Cylkro face gear transmissions benefit from the advantage of axial freedom of the pinion at the mounting of the gear set (Fig. 3).

Compared to traditional angular transmissions such as bevel gear sets and worm gear sets, in which both gears have to be adjusted very precisely and even in pairs, the spur Cylkro face gear set only requires adjusting of the face gear. Thanks to the axial freedom of the cylindrical pinion, the axial position of the pinion does not affect the contact pattern.

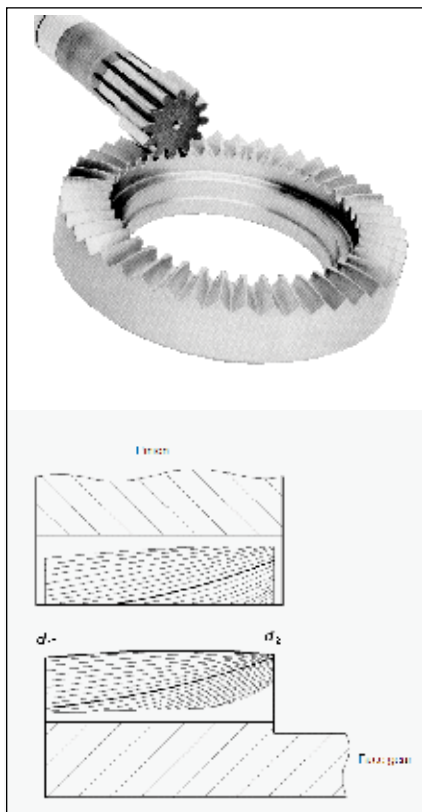

**Figure 1—Face gear set (above) and helical contact lines on pinion and face gear.**

Pinions can be exchanged easily and do not require meshing in pairs with the Cylkro face gear. This is of great benefit when there is expansion in the pinion axis due to heat generation. Or, the feature can also be utilized when the axial freedom becomes part of the application's function. For example, Saueressig embossing machines use the feature to slide one embossing cylinder closer to the second embossing cylinder. Another example is the starter gear in the Porsche Carrera GT, of which only an exclusive 1,200 cars were built and in which the pinion is axially pushed into the face gear at the moment of starting the engine.

It is possible to choose any axis angle between 0° and 135°, of which 90° is the most common. Smaller axis angles, such as 17°, are used in mixing equipment or driven tools with 45° angles from Sauter Feinmechanik GmbH (Fig. 4) and Benz-driven tools for the metal working industry.

Face gear sets with a helix angle are used, for instance, in automatic door systems. In this example (Fig. 5), the pinion only has three teeth and is shaped almost like a worm. However, the helical Cylkro transmission's efficiency remains very high as compared to the loss of efficiency in worm gear sets. Another advantage, specifically for the door system application, is the lack of self-braking factor. This means that in case of power failure and emergency, the doors can be opened easily by hand.

Gear ratios in the range of 1:1 to 1:5 are the typical choice for power applications. Larger gear ratios are more often used in hand-driven applications or in precision solutions such as printing machines or optical machinery from Zeiss. U.S.-based Danaher Motion has a full range of angle gear heads in which a total of 29 different Cylkro face gear sets are used. The gear head range is divided into five sizes, each size covering a gear ratio range of 1:1 to 1:5.

Finally, the multiple-power transmission—in which one or more pinions mesh with one wheel or between two Cylkro face gears—has been real-

ized, for instance, in Hydrosta BV bow thrusters (Fig. 6) and Index Traub turning machines (Fig. 7).

**continued**

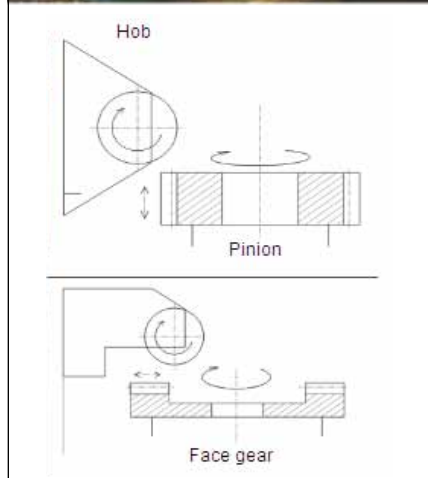

**Figure 2—Manufacturing of Cylkro face gears by a six-axis CNC spur gear hobbing machine.**



**Figure 3—Axial freedom of the pinion in face gear transmissions.**

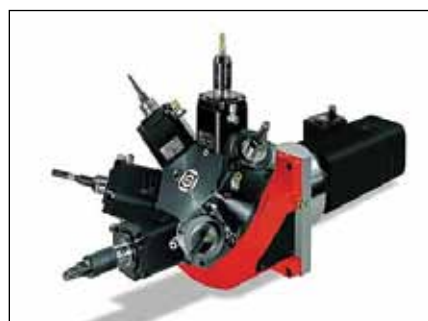

**Figure 4—Compact tool changer based on face gear transmission.**



**Figure 5—Automatic door moving system with Cylkro transmission.**



**Figure 6—Cylkro face gears in counter-rotating bow thrusters achieve higher efficiency.**



**Figure 7—Multimodal Index Traub turning machine with inner and outer face gear rings.**

## Center Differential of the New Audi Quattro with Cylkro Face Gear Technology

An enormous breakthrough for the multiple-power Cylkro face gear transmission in the field of automotive applications was the introduction at the Geneva Autosalon earlier this year of the new Audi Quattro RS 5 with a self-locking crown gear differential in the Quattro drive train, which regulates the power distribution between the front and rear axles.

Two Cylkro face gears with different tooth geometries, resulting in a 40:60% torque split, are built into this lightweight differential (4.8 kg). ASSAG was given the responsibility of developing the tooth geometry of the face gears and pinions that are used in the heart of the Quattro drivetrain. Finally the successful cooperation resulted in a common patent applica-

tion and ASSAG granted a license for serial production of the Cylkro face gears. Using the Cylkro face gear technology, Audi could realize a weight reduction of 2 kg compared to the conventional differential. Furthermore, the package of plates of the differential could be considerably reduced.

**How it works.** The Cylkro face gear with the largest number of teeth (Fig. 8, left side) is connected with the cardan shaft to the rear axle. The second face gear takes care of the power take-off to the front axle. In between the face gears, four planetary pinions are equally spaced at 90° in a planet carrier that is driven by the outgoing axis of the S-tronic 7-speed gearbox with double clutch.

The self-locking crown gear center differential attains a high efficiency ratio. This standard rear-biased configuration ensures sporty handling of

the vehicle. In the basic situation, there is no difference in rotational speeds of the face gears and the planet carrier. If one of the axles starts to spin, for example, while it is on ice or snow, the self-locking face gear center differential will immediately engage. By a package of plates, the differential can widely vary the torque distribution between the front and rear axles. Up to 70% of the drive force can be fed to the front, and as much as 85% toward the tail-end (Fig. 9).

ASSAG could realize this wide variation by exactly locating and tolerating the contact patterns between the pinions and face gears. These contact patterns have been pre-defined by ASSAG within specified limitations. This leads to certain axial forces on the face gears and on the package of plates, finally resulting in a variation of the torque distribution in such a way that ASSAG could fulfill all Audi specifications.

In the crown gear differential, the gears are mounted without backlash. The result is a homogeneous conversion of the torque distribution without any delay. In conjunction with intelligent software in the braking system, the Quattro system assigns optimal torque to every driven wheel. Interventions of the ESP system will be reduced to a minimum. This increases the drivability of the Audi RS 5 in every situation. (After the release of the RS 5, Audi will equip future Quattro series with the face gear differential.)

**Catalog products.** The earlier mentioned Danaher's gear range was the instigator for ASSAG to look at its own standard range of catalog Cylkro face gear sets. This way, Cylkro face gear sets would also become available as a standard program allowing short delivery times and competitive prices. The program covers torques from 0.7 to 518 Nm at ratios up to 1:10. More information on the standard program is available in the Cylkro catalog or

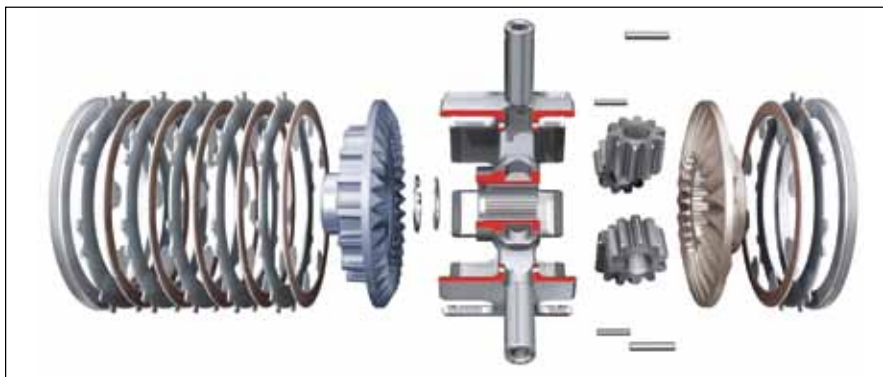

Figure 8—Detail of the Audi Quattro RS 5 center differential.



Figure 9—Embedded face gear center differential.

online on the ASSAG homepage.

**Evolvere solutions.** With the takeover by ASSAG Switzerland, new engineering knowledge and experience became available for the Cylkro technology. It found its way to the market not only as a face gear set, but, thanks to ASSAG's "Evolvere" concept, it is now also available as a complete angular gearbox. Evolvere is Latin for "to evolve" and so the Evolvere trademark stands for the optimal added value of Swiss transmission technology. It includes support in evaluating the best solution, considering cost-effective components and easy mounting and maintenance. ASSAG engineers construct transmissions of all types, for all kinds of industries and design animated 3-D models.

ASSAG provides three types of standard Evolvere gearboxes:

- Block-shaped gearboxes for 90° transmission ratios 1:1 to 1:4 (Fig. 10)
- Compact, flat gearbox for 90° transmissions with ratios 1:5 to 1:10 (Fig. 11)
- Octagonal gearboxes (Octodrive) for different angles and multiple inputs/outputs with ratios 1:3 and higher (Fig. 12).

All of them use the standard Cylkro face gear sets from the Cylkro catalog as described earlier.

**Octodrive Transmission Offers Customer-Driven Choices**

ASSAG's angular gearbox program—Octodrive—affords customers the freedom of choosing the number of inputs, outputs, angles, ratios and other options. The customer has the possibility to design the gearbox according to his needs by choosing the relevant components in a dialog window. This allows for generation of multifunctional and high-quality angular gears quickly, with the resulting octagonal gearbox available from ASSAG partners or via the internet.

Octodrive face gear drives are **continued**

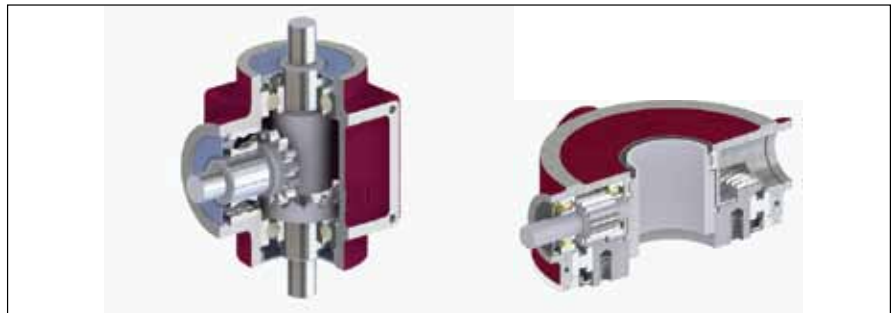

**Figure 10—Block-shaped 1:1 and flat 1:5 versions of the Evolvere angular gearbox family.**

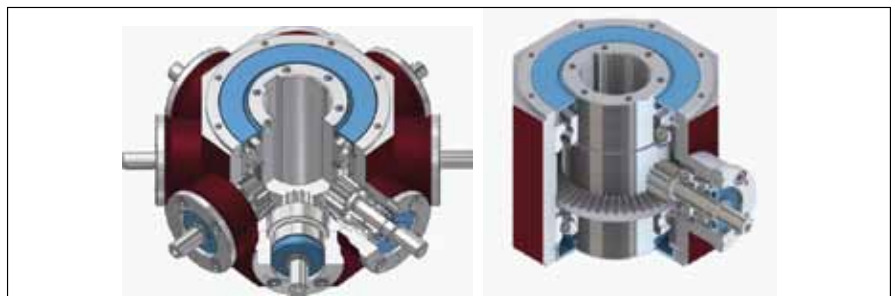

**Figure 11—Octodrive gearbox (sectional view) in different configurations.**



**Figure 12—Up to eight pinion shafts on one layer can be mounted (left). Depending on the application, only one output may be needed. If required, it can be combined with a second face gear.**



**Figure 13—Application examples of Octodrive face gear transmissions: table-adjustment and multiple-lift drive combination.**

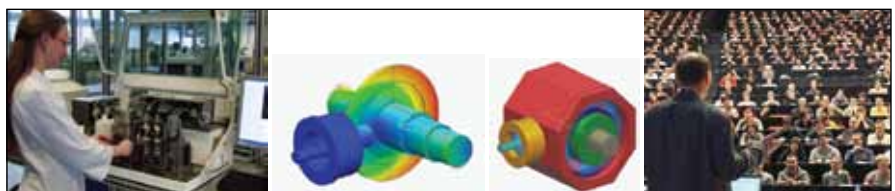

**Figure 14—As a tool for researchers and educational purposes, Octodrive allows for the understanding, advancement and teaching of gear and transmission technologies under many aspects.**

delivered with output torques from 29 to 255 Nm and modules 0.7 to 3.5 with ratios 1:3 up to 1:10 (Table 1). This spectrum enables Octodrive to be applied in a large variety of applications. Hollow- or solid-shaft, as well as different options for motor adaptations, can be chosen (Fig. 12).

**Clean technology.** Friction-

minimized angular ball bearings and optimized geometry and topology of the teeth out of hardened steel result in an efficiency factor of the gear transmission > 95%. High load capacity and long durability are realized despite a moderately light construction principle. It is grease-lubricated for life.

Based on self-oscillation analyses

as well as optimization of tooth geometry and topology, the Octodrive transmission is designed for minimal noise generation with focus on the expected driving speed and load distributions.

**Easy application.** Octodrive is delivered along with a final testing certificate. Based on its octagonal form and self-centering of norm flanges, the gearbox fits practically anywhere and is implemented in a short time by the customer.

**Large field of applications.** Whether as a lifting unit, tool exchanger, in a robot, as part of a packaging line or as an angular gearbox of a robot, Octodrive fulfils the expected flexibility, bifurcation or inversion of the movement (Fig. 13). It enables the development of prototypes of complex machines in a timely fashion.

**Synergies.** The use of face gear sets based on the official Cylkro pro-

## ECONOMICAL SOLUTIONS FOR PRECISION GEAR GRINDING

Riverside Spline & Gear is proud to feature our new Hoffer Rapid 900 Gear Grinder, offering the latest in form grinding technology. With AGMA class 14+ capability, and on-board gear inspection, you are assured that your gear will meet all design specifications.

### External Gears

Gear Diameter	50-1000 mm
Center Distance Above Table	360-1360 mm
Axial Stroke (Max)	650 mm
Helix Angle	+/- 45°, 90°
Module	1-25 mm <i>(extendable to 34 mm)</i>
Profile Height	41 mm <i>(extendable to 60-80 mm)</i>
Grinding Wheel Width	60 mm <i>(extendable to 90 mm)</i>
Grinding Wheel Diameter	400 mm
Table Load	3000 kg



**WITH OVER 45 YEARS OF EXPERIENCE, IT'S EASY TO SEE WHY INDUSTRY LEADING MANUFACTURERS CHOOSE RIVERSIDE AS THEIR #1 GEAR GRIND SOURCE.**



**Riverside Spline & Gear Inc.**  
P.O. Box 340 • Marine City, MI 48039  
Phone: (810) 765-8302 • Fax: (810) 765-9595  
valerief@splineandgear.com  
**splineandgear.com**

**Table 1—Scale of the Octodrive program. M1 refers to the maximal constant torque at the pinion shaft.**

Diameter (mm)	MI (Nm)	Ratio	Modul
95	18	3	1.25
95	12	4	1
95	9	5	0.9
95	5	6	0.7
115	30	3	1.5
115	22	4	1.25
115	14	5	1
115	10	6	0.9
115	5	8	0.7
140	50	3	1.75
140	39	4	1.5
140	27	5	1.25
140	15	6	1
140	10	8	0.9
140	5	10	0.7
160	64	4	1.75
160	47	5	1.5
160	29	6	1.25
160	16	8	1
160	10	10	0.9

gram allows the customer to order angular gearboxes with leading gearing technology and Swiss quality directly from the catalog at ASSAG's distribution partners or via Internet.

### Summary and Forecast

During the past 20 years, the concept of a face gear transmission has developed into a well-defined, practice-proven and widely applied transmission, with the latest Cylkro success being the breakthrough in the automotive industry. Now available as a catalog product and as part of Evolvere and Octodrive gearboxes, the technology has become available to the standard gear market as well. ASSAG engineers continue to explore the possibilities of the Cylkro technology, both in the fields of application and in production techniques.

*Cylkro and Evolvere are registered trademarks of ASSAG.*

### For more information:

ASSAG  
Hauptstrasse 50  
CH-3186 Dürdingen  
Switzerland  
Phone: +(41) 26-492-99-11  
Fax: +(41) 26-492-99-10  
[info@assag.ch](mailto:info@assag.ch)  
[www.assag.ch](http://www.assag.ch)

## Zeiss

### OFFERS NEW MEASURING CAPABILITIES

With DuraMax, Carl Zeiss offers a compact 3-D coordinate measuring machine. DuraMax Gear transitions DuraMax into a shop floor gear measuring machine. "This enables us to fulfill the requests of many customers and introduce gear wheel measuring technology with small machines

that can be used as close to production as possible," says Alexander Dollansky, product manager at Carl Zeiss Industrial Metrology.

The key features of DuraMax Gear are its suitability for a rough production environment and high permissible temperature fluctuations. DuraMax is

suited for process control on the production floor, for quick in-between inspections of small workpieces and for testing volume parts directly in production. Because of its accuracy, DuraMax can also be utilized for many requirements in gear measuring tech-

**continued**



### It's amazing how far you can go with the right travel gear.

You could travel the world and not find a gear manufacturer who combines a range of capabilities, quality and commitment to customer service the way Schafer Gear does. Schafer manufactures gears for many industrial applications including transportation and agricultural equipment. Our gear products range from spur and helical to bevel and worm. And every gear we make comes with one thing standard – prompt, courteous and exceptional service.



**SCHAFER**  
GEAR WORKS, INC.

South Bend, IN/Rockford, IL

Find out more at [schafergear.com](http://schafergear.com)  
or call us at 574-234-4116.

© 2010 – Schafer Gear Works, Inc.