



# Measurement Error Induced by Measuring over Pins Instead of Balls

Richard D. Keiper

**T**he purpose of this article is to clarify some terms and methods used in measuring the size of gears. There is also an explanation given of the error induced and how to correct for it in certain cases when the measurement is made using pins instead of balls.

## Different Methods of Measuring Gears

Gear size can be specified in many ways. One way is to express the size of a gear in terms of tooth thickness—transverse circular tooth thickness, normal circular tooth thickness, transverse chordal tooth thickness or normal chordal tooth thickness. Another way is to express size in terms of what might be seen on a tight mesh rolling checker—functional tooth thickness, center distance, pitch radius or pitch diameter. Another way is to express size in terms of an over-ball or over-pin dimension. This last method is the most widely accepted way of specifying the size of a gear because it is the quickest and easiest way of measuring size.

## Measuring Using Balls and Pins

Actually the terms "over balls" and "over pins" apply only to external gears. Internal gears are measured "between balls" or "between pins," but because external gears are far more common than internal ones, the term "over" sometimes gets used universally.

The terms "over balls" and "over pins" are also sometimes misapplied with external gears. This happens when the measurement called for is actu-

ally a "dimension over one ball" or a "dimension over one pin." To measure a gear over one ball or pin, an arbor is used to establish the center, which is the zero reference for the measurement. All external gears can be measured over one ball or over one pin.

All external spur gears can be measured over two balls or over two pins, but when the gear being measured has an odd number of teeth, the dimension over two balls or pins is less than twice the dimension over one ball or pin because no two tooth spaces will lie on a diameter. What is actually being measured in that case is a chord, not a diameter. To eliminate any confusion, some designers always specify the size of external gears as a dimension over one ball or pin and never as a dimension over two balls or pins.

In the case of internal gears, size is always specified in terms of "between balls" or "between pins" since, in most cases, there is no way to establish the center of the gear to measure a dimension "between one ball" or "between one pin."

## Using Pins Instead of Balls

Theoretically, for external gears with an even number of teeth, the dimension obtained by measuring over two balls will be the same as the dimension obtained by measuring over two pins of the same diameter. In practice, sometimes, such as when the part is hobbled, it is desirable to measure over two pins instead of over two balls. In that case, a ball may fall in the scallops of the hobbled tooth on one measurement and then ride up on a high spot of the hobbled surface on the next measurement. This causes the measurements to be inconsistent, making it difficult to determine what size the gear really is.

When pins are used instead of balls, they contact only the high spots of the hobbled surface every time the gear is measured. This makes the readings consistent, thereby making it possible to control the size of the gears. However, when two pins are used to measure helical gears with an odd number of teeth, a measurement error is induced.

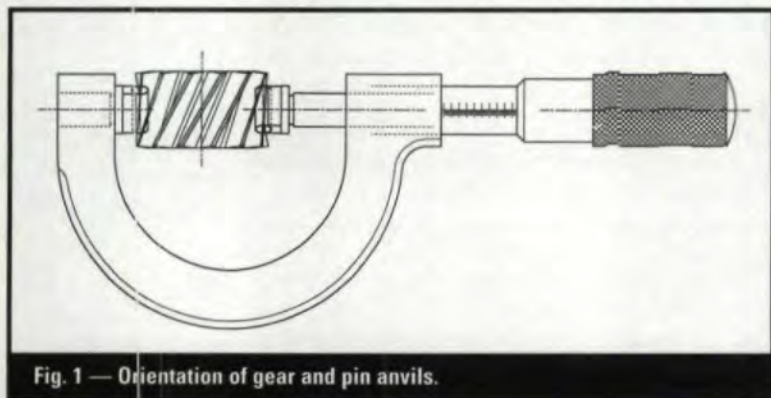

Fig. 1 — Orientation of gear and pin anvils.

Whenever pins are used to measure internal helical gears, an error is induced. In this article we will deal with external helical gears only.

### Construction of Measuring Instruments

The accepted method of construction for pin micrometers and for specialized over-pin measuring instruments is to constrain the two pins to always lie in planes that are parallel to one another. This is done by rigidly mounting the pins to anvils whose axes lie on the same line; in other words, the anvil shafts are coaxial. The anvil shafts are free to rotate 360°.

The orientation of the gear and the pin micrometer in the following example is with the axis of the gear vertical and the anvil shafts of the micrometer lying in the transverse plane (see Fig. 1).

### Error Induced by Using Pins

To illustrate what happens when one tries to measure an external helical gear with an odd number of teeth over pins, let's imagine that we can remove the pin anvils from the pin micrometer.

Let's say that we want to measure an external helical gear using two pins instead of two balls. The gear has 13 teeth, a helix angle of 30°, a design pitch diameter of 1.531" and a dimension over two .125" diameter balls of 1.825". Let's assume that the pin contact diameter of the gear is exactly at the design pitch diameter, which is usually pretty close to being the case for most gears and pin sizes.

Now, with the anvils removed from the pin micrometer, we engage the pins in tooth spaces on the gear that lie as close to a diameter as possible, with the axes of the anvils lying in the same transverse plane.

In order for the axes of both anvil shafts to lie in the same transverse plane, they must lie on radius lines of the gear, with both pins fully engaged in the tooth spaces. These radius lines will be separated by an angle of  $360^\circ / (2 \cdot 13)$  or 13.846°. In other words, the angle between each anvil shaft and the horizontal line that intersects the axis of each shaft at the centers of the pins (of each anvil) is  $13.846^\circ / 2$ , or 6.923° (see Fig. 2). Since this is not the configuration the shafts are constrained to be in when they are in the pin micrometer, it is clear that there will be an error induced when they are moved to that position. Assuming the pin contact diameter of the gear was exactly at the design pitch diameter, the angle between the vertical plane in which the anvil shaft lies and the axis of the pin is the helix angle of the gear or 30°.

To determine the amount of error induced, we need to calculate how much the pins move when the anvil shafts are moved to be coaxial to each

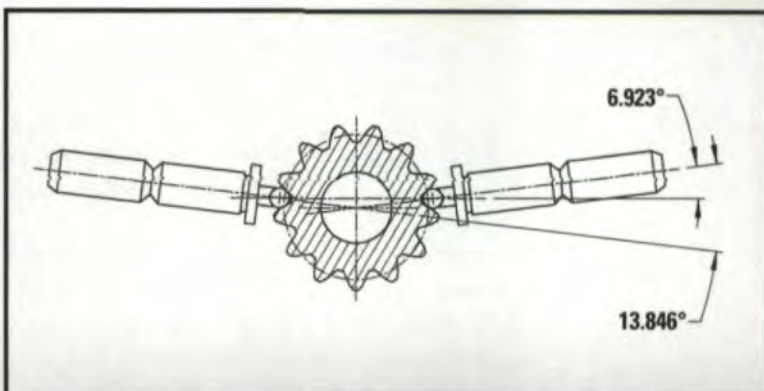

Fig. 2 — Pin anvils removed from micrometer with pins fully engaged in tooth spaces of gear.

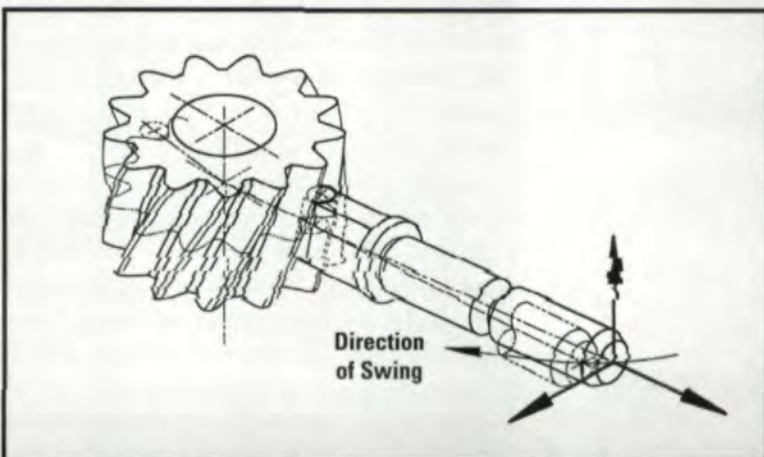

Fig. 3 — Direction of swing of right-hand anvil shaft. Left-hand anvil shaft swings the same amount in the opposite direction.

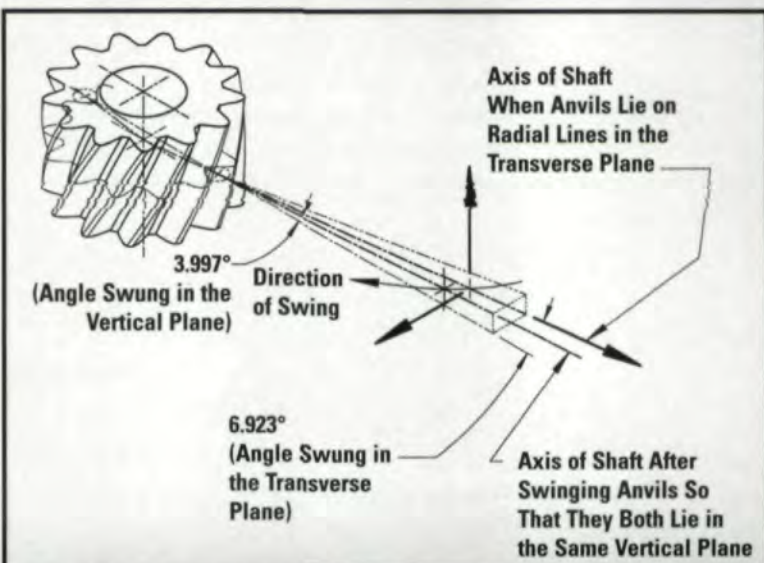

Fig. 4 — New position of anvil shafts after swinging them to lie in the same vertical plane.

other. They now lie in the same transverse plane, but not on the same chord by an angle of 6.923°. To move them first swing the shafts of the anvils so that the pins stay engaged in the tooth spaces and rotate about their (the pins') axes (see Figs. 3-4). When we do this, both anvil shafts lie in the same vertical plane, but they are not coaxial, and they do

**Richard D. Keiper**

is a product engineer with Moore Products Co. Gage Division, Spring House, PA.

not lie in the transverse plane anymore. After we have swung the anvil shafts, the angle between these shafts and the transverse plane is  $6.923^\circ \cdot (\tan 30^\circ)$  or  $3.997^\circ$ . So, to move both anvil shafts to be coaxial and lie in the transverse plane, we need to swing them both in the same vertical plane through an angle of  $3.997^\circ$  (see Fig. 5).

When we do this, the positions of the pin anvils are what they would be if constrained in the pin micrometer. If the line of contact on the tooth were a straight line instead of a helix, the amount that the center of each pin (i.e., the point of intersection of the axis of the shaft and the axis of the pin) would move out away from the center of the other pin would be equal to half the vertical length of each pin times the tangent of the angle of swing, or  $\sqrt{\{(L/2) \cdot (\sin 30^\circ) \cdot (\sin 6.923^\circ)\}^2 + \{(L/2) \cdot (\cos 30^\circ)\}^2} \cdot (\tan 3.997^\circ)$ , where  $L$  is the length of the pins (see Fig. 6).

But since the line of contact is a helix, the amount that the helix moves out of the plane that is perpendicular to the axis of the anvil shaft, over half the length of the pin, must be subtracted from the amount the pins move out away from each other. The amount the helix moves out from the plane is equal to  $(1.531/2) \cdot [1 - \cos\{360^\circ \cdot (L/2) \cdot \cos(90^\circ - 30^\circ)/(\pi \cdot 1.531)\}]$ .

The expression that describes the amount that the center of one pin moves out away from the center of the other pin then becomes  $\sqrt{\{(L/2) \cdot (\sin 30^\circ) \cdot (\sin 6.923^\circ)\}^2 + \{(L/2) \cdot (\cos 30^\circ)\}^2} \cdot (\tan 3.997^\circ) - (1.531/2) \cdot [1 - \cos\{360^\circ \cdot (L/2) \cdot \cos(90^\circ - 30^\circ)/(\pi \cdot 1.531)\}]$ .

Since this is the amount that each pin moves out, the total amount of error is twice this amount,

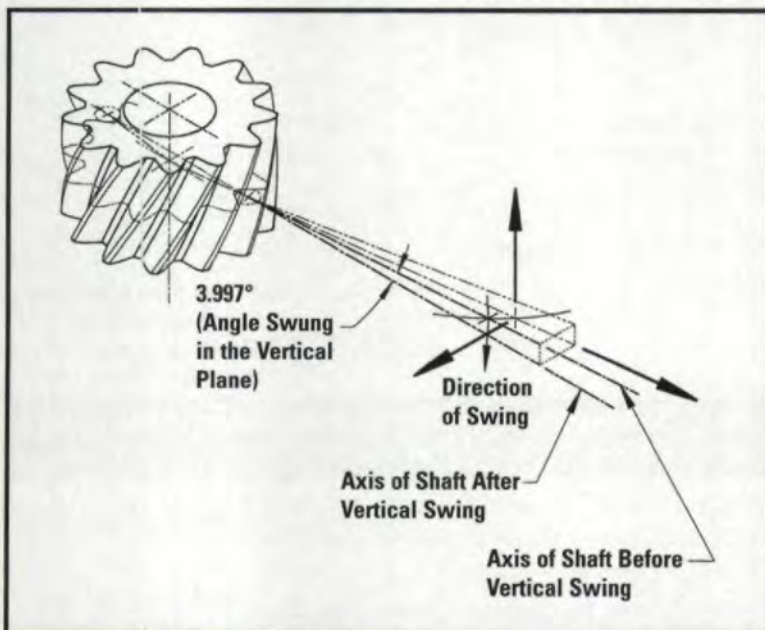

Fig. 5 — New position of anvil shafts after swinging them in the vertical plane to lie in the same transverse plane and be coaxial.

$$\text{or } 2 \cdot \sqrt{\{(L/2) \cdot (\sin 30^\circ) \cdot (\sin 6.923^\circ)\}^2 + \{(L/2) \cdot (\cos 30^\circ)\}^2} \cdot (\tan 3.997^\circ) - 1.531 \cdot [1 - \cos\{360^\circ \cdot (L/2) \cdot \cos(90^\circ - 30^\circ)/(\pi \cdot 1.531)\}].$$

In general form, this error is expressed as

$$e = 2 \cdot \sqrt{\{(L/2) \cdot (\sin \psi) \cdot (\sin(360^\circ/4N))\}^2 + \{(L/2) \cdot (\cos \psi)\}^2} \cdot \{\tan((360^\circ/4N)\tan \psi)\} - PD \cdot [1 - \cos\{360^\circ \cdot (L/2) \cdot \cos(90^\circ - \psi)/(\pi \cdot PD)\}]. \quad (1)$$

Since the quantity  $\{(L/2) \cdot (\sin \psi) \cdot (\sin(360^\circ/4N))\}^2$  will always be essentially zero (except for cross-axis gears), the general form can be approximated by

$$e = L \cdot (\cos \psi) \cdot \{\tan((360^\circ/4N)\tan \psi)\} - PD \cdot [1 - \cos\{360^\circ \cdot (L/2) \cdot \cos(90^\circ - \psi)/(\pi \cdot PD)\}]. \quad (2)$$

where:  $e$  = error

$L$  = length of pins

$N$  = number of teeth in gear

$\psi$  = helix angle of gear

$PD$  = pitch diameter of gear

This approximation is only accurate when the pins are relatively short. When the gear tooth is relatively long and the pins are relatively long, that is, long enough that the pin intersects the vertical plane that passes through the diameter of the part and is parallel to the anvil shafts, then the error is no longer a function of the length of the pins (see Fig. 7).

The length of the pin that is needed to intersect this vertical plane is given by

$$CL = PD \cdot (\sin(360^\circ/4N))/(\sin \psi). \quad (3)$$

where:  $CL$  = critical length of pins

$PD$  = design pitch diameter of gear

$N$  = number of teeth on gear

$\psi$  = helix angle of gear

In our example the pin length that intersects this plane would be  $1.531 \cdot (\sin(360^\circ/52))/(\sin 30^\circ) = .369$ ".

When the pin length is greater than or equal to this "critical length," and the tooth on the gear is long, then the error is limited to the error calculated from Equation 2, using this  $CL$  as the length of the pins.

In order for the critical length of the pins to be the limiting factor, the tooth length on the gear must also be greater than or equal to the critical length of the pins.

The tooth length on the gear can be approximated by

$$TL = FW/\cos \psi. \quad (4)$$

where:  $TL$  = tooth length on gear

$FW$  = face width of gear

$\psi$  = helix angle of gear

When the pin length is greater than the critical length, but the tooth length is less than the critical length, then the error is limited to the error calculated from Equation 2, using this  $TL$  as the length of the pins (see Fig. 8).

Then the error can be calculated by using the least of the three lengths—actual pin length, critical pin length (Equation 3) or tooth length (Equation 4) as the pin length in Equation 2.

In our example the limiting factor is the critical length of the pins. When we use this as the length in Equation 2, we obtain:  $e = .369 \cdot (\cos 30^\circ) \cdot (\tan((360^\circ/52) \cdot \tan 30^\circ)) - 1.531 \cdot [1 - \cos \{360^\circ \cdot (.1845) \cdot \cos(60^\circ)/4.810\}] = .0112"$ .

This error would have to be subtracted from the measurement obtained using pins to obtain the correct dimension over balls for this gear.

It should be noted that when pins shorter than the critical length are used, or when the tooth length on the gear is less than the critical length, the pins contact the gear at a point. In theory, the type of contact between the pins and the gear teeth is always point contact, but when the pins and the teeth are sufficiently long, the lines on the surface of the pin parallel to the pin's axis that contact the gear teeth are tangent to the involute helicoid at the contact diameter of the gear. This is not the case when either the pins or the gear teeth are less than the critical length. When the pin length is less than the critical length, the pins contact the gear at the end of the pins. When the tooth length is less than the critical length, the pins contact the gear at the end of a tooth. When either of these is the case, any advantage gained by the use of pins in contacting only the high spots may be negated by the fact that contact between the pin and the gear is point contact, and the point of contact of the pin may fall into scallops on the hobbled surface.

#### Correcting for the Error

Pins longer than the "critical length" can be used to obtain consistent measurements on rough helical gears with an odd number of teeth, but the measurement should be made on a measuring instrument that allows fixturing of the part to ensure that the axis of the part is held perpendicular to the axis of the anvil shafts. A pin micrometer should not be used.

This method can be used to control a process without knowing what the actual size of the gear is. If it is important to know the correct size of the gears, then the correct dimension over balls can be determined by subtracting the error, calculated in Equation 2, from the dimension measured over pins. ⚙

*Illustrations for this article were done by Paul Romanowsky.*

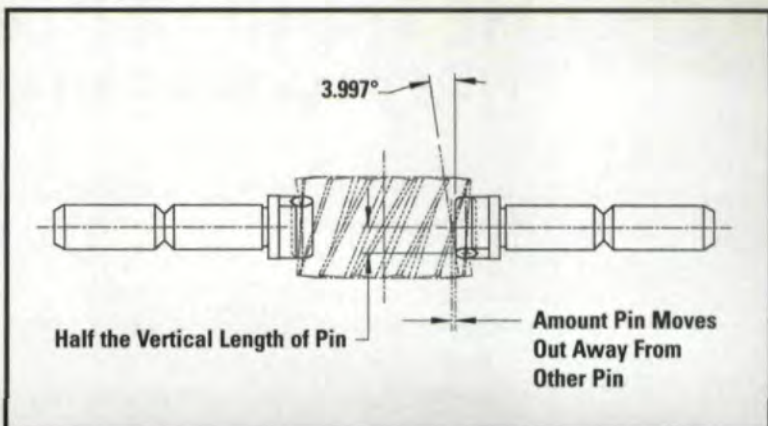

Fig. 6 — Distance pin moves out away from the other pin when anvil is swung in the vertical plane.

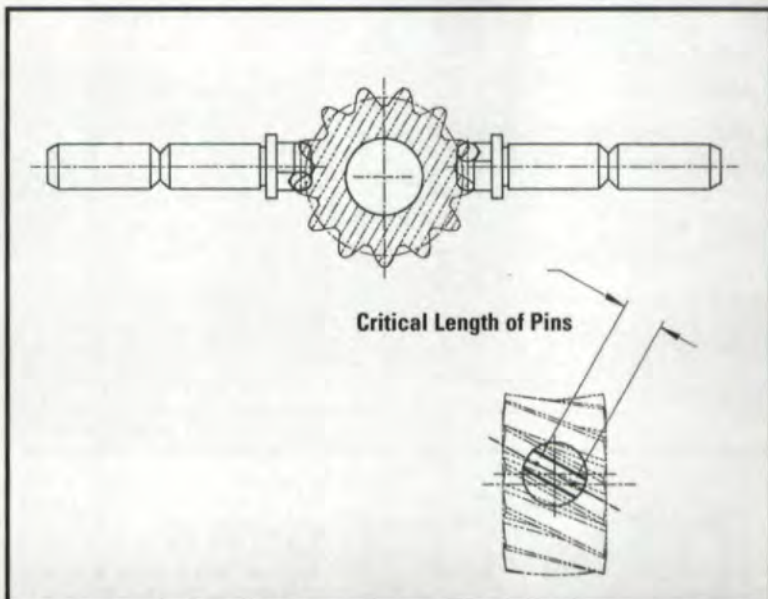

Fig. 7 — The critical length of the pins for this particular gear.

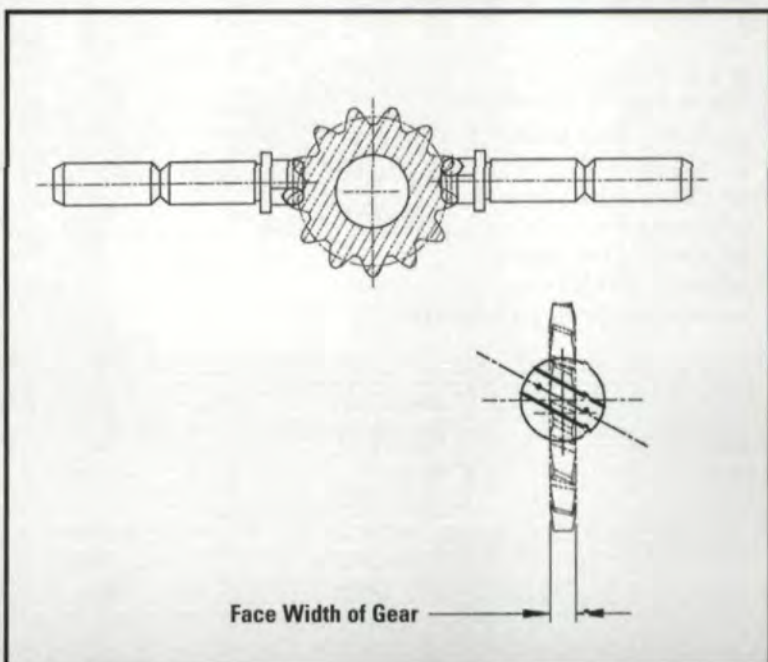

Fig. 8 — A gear where the limiting factor is the tooth length because it is less than the critical length of the pins.

**Tell Us What You Think...**  
 For more information about Moore Products Co., please circle 212.  
 If you found this article of interest and/or useful, please circle 213.