

# Involute Spline Size Inspection

by

William L. Janninck & John C. Nielsen  
ITW Illitron  
Illinois Tool Works Inc.

---

## Abstract

This article describes a new technique for the size determination of external involute splines, by using a span measuring method. It provides application performance information demonstrating how this method and its measurements correlate with the traditional spline ring gage sizing method.

---

Involute splines provide a positive rotational coupling between a shaft with external teeth and related mating member with internal spline teeth. Their use permits ease of assembly or disassembly for replacement or servicing, and permits fixed or sliding connections. Other uses permit compact assembly of parts, or by use of standardized fittings, the intercoupling of motors with gear boxes or other loads.

Since there is no rolling action between the mating members, as there is between meshing gears, all of the spline teeth are expected to fit together. Although various internal and external fits are available, the final goal of involute splines is to achieve a self centering condition with full contact bearing. The result of this would be equalized load sharing and stress on all the teeth.

Various manufacturing induced errors diminish this ideal equalized condition up to the point where a spline may fail to properly engage its mating member. Some typical factors which affect proper mating are: tooth thickness, space width, index errors, profile variations, lead variation and out of roundness. Among the manufacturing processes the one most difficult to deal with is heat treating. It is particularly troublesome if the part is slender, thin walled or tubular, because distortion becomes extremely likely and also probably irregular.

To screen out parts which will not mate properly or not mate at all, it is necessary to inspect the product prior to the assembly operation. A very common

way of doing this is by the use of solid tool steel gages. For external splines, the gages are internal toothed rings called "GO" and "NO GO". (See Fig. 1).

The "GO" ring is a composite gage having a full complement of teeth and is used to inspect maximum material conditions, minimizing the chance of fit interference. In other words, if the part fits the "GO" gage, there is a high probability of assembling with its mate later. The "GO" gage cannot measure the looseness or size of the part being gaged. It can only reject those parts that will not enter the "GO" gage.

The "NO GO" gage does not have a full compliment of teeth, but rather only two diametrically opposed groups of teeth. It is used to inspect minimum material conditions, thereby, governing the maximum looseness. If the spline part is thin walled, or tubular, or heat treated, it is desirable to try the "NO GO" gage in at least two places 90 degrees apart. An oval part, for example, may enter the "NO GO" gage at the low point, but not the high. Ovality reduces the chances of getting the full use of all the teeth in the final assembly. At this point a few definitions would be in order. (See Fig. 2).

**Profile Variation:** Deviation from specified involute profile normal to the flank surface with zero established at the pitch line. Positive errors reduce clearance or increase interference. Negative errors increase clearance and reduce contact area.

**Index Variation:** The difference between the actual and true spacing of any two teeth, adjacent or not.

**Effective Tooth Thickness:** The space width of a perfect mating internal spline for a fit without looseness or interference.

**Actual Tooth Thickness:** The actual measured tooth thickness on the pitch line which is equivalent to the effective tooth thickness, less width allowance for profile and index errors.

The "GO" composite spline gage is used to inspect the effective tooth

thickness down to the form diameter. These gages must be very precise, since they are used as the perfect mating member, and any tolerances allowed would steal from the part tolerance.

The "NO GO" sector ring gage containing opposing sectors of about two teeth is used to check the minimum actual tooth thickness.

Using these gages requires a degree of manual dexterity. The "GO" gage needs to be tried in only one angular position, but some skill is required to start the

---

## AUTHORS:

**MR. W. L. JANNINCK** is Technical Manager for the ITW-Illitron Division of Illinois Tool Works Inc. He has been involved in the design and application of many types of metal cutting tools specializing in the area of tooling and gaging for the manufacture of gears, splines and sprockets of both generating and forming types. He was Chief Engineer and Manager of Product Engineering from 1979 through 1984 for the Illinois Eclipse Division. He has served on various committees of the AGMA and MCTI and is Chairman of the AGMA Cutting Tool Committee. He also served on the SAE-ANSI Involute Spline Committee and the ASME-ANSI Committee on Power Transmission Chains and Sprockets. He has written several articles on tooling subjects and has spoken at various SAE, SME, ASQC and AGMA meetings. He was educated at Northwestern University.

**MR. JOHN C. NIELSEN** has been a staff member of the ITW corporate machine development group for 10 years. Subsequently he became supervisor of the group. He has been responsible for the design or project management of a wide variety of equipment relating to new product entry or productivity improvement for fastener, cutting tool and capacitor manufacture and underwater cable handling. He currently specializes in inspection instrument development.

Prior to ITW, his design experience was in the development of new business machines for Bell & Howell - Ditto and electronic countermeasures equipment for Northrop (Hallicrafters).

He holds a Bachelor of Science degree in Mechanical Engineering from Purdue University and is a member of the American Society of Mechanical Engineers.



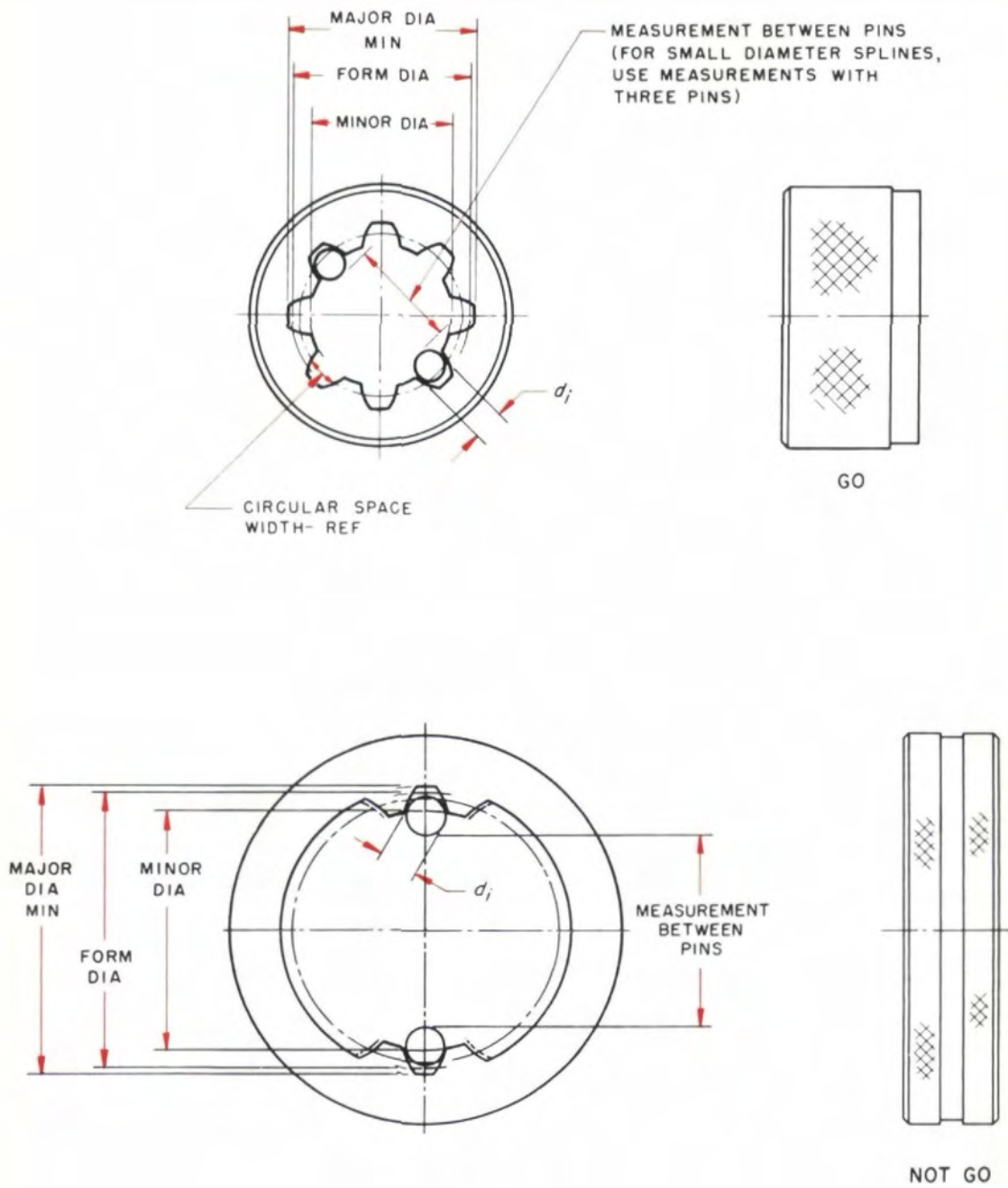
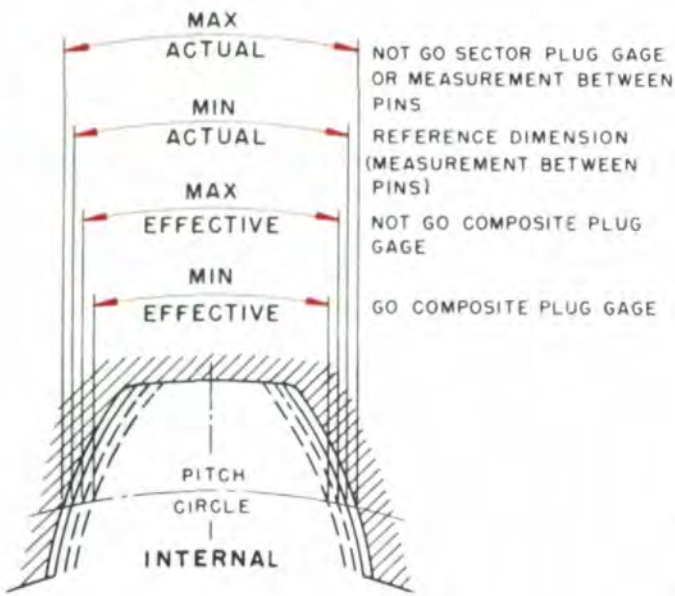
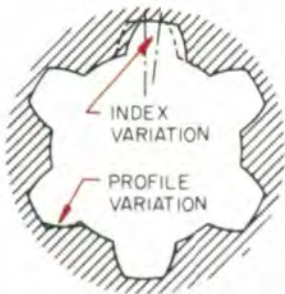
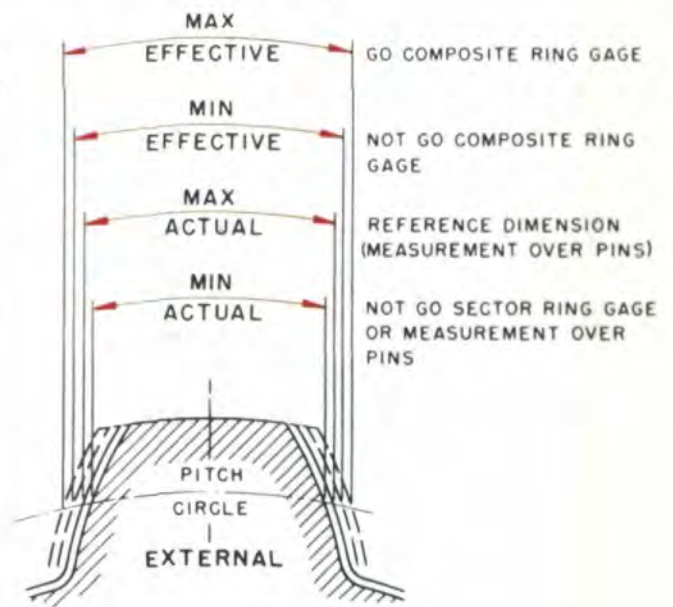

Fig. 1

**CIRCULAR SPACE WIDTH**



**CIRCULAR TOOTH THICKNESS**



EACH SPACE IS BASIC WIDTH.

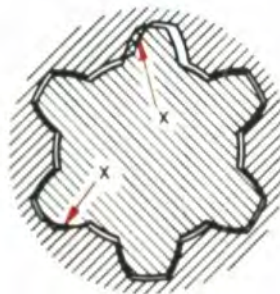

THE PERFECT EXTERNAL SPLINE WITH BASIC TOOTH THICKNESS INTERFERES AT X.



THE PERFECT EXTERNAL SPLINE FITS IN ANY POSITION, IF ALL SPACES ARE WIDENED BY THE AMOUNT OF THE INTERFERENCE.

**EFFECT OF VARIATIONS ON INTERNAL SPLINE**



ACTUAL TOOTH THICKNESS

EFFECTIVE TOOTH THICKNESS EQUALS SPACE WIDTH OF PERFECT INTERNAL SPLINE

THE PERFECT INTERNAL SPLINE FITS IN ANY POSITION, IF ALL TEETH OF THE EXTERNAL ARE NARROWED BY THE AMOUNT OF THE INTERFERENCE.

**EFFECT OF VARIATIONS ON EXTERNAL SPLINE**

Fig. 2



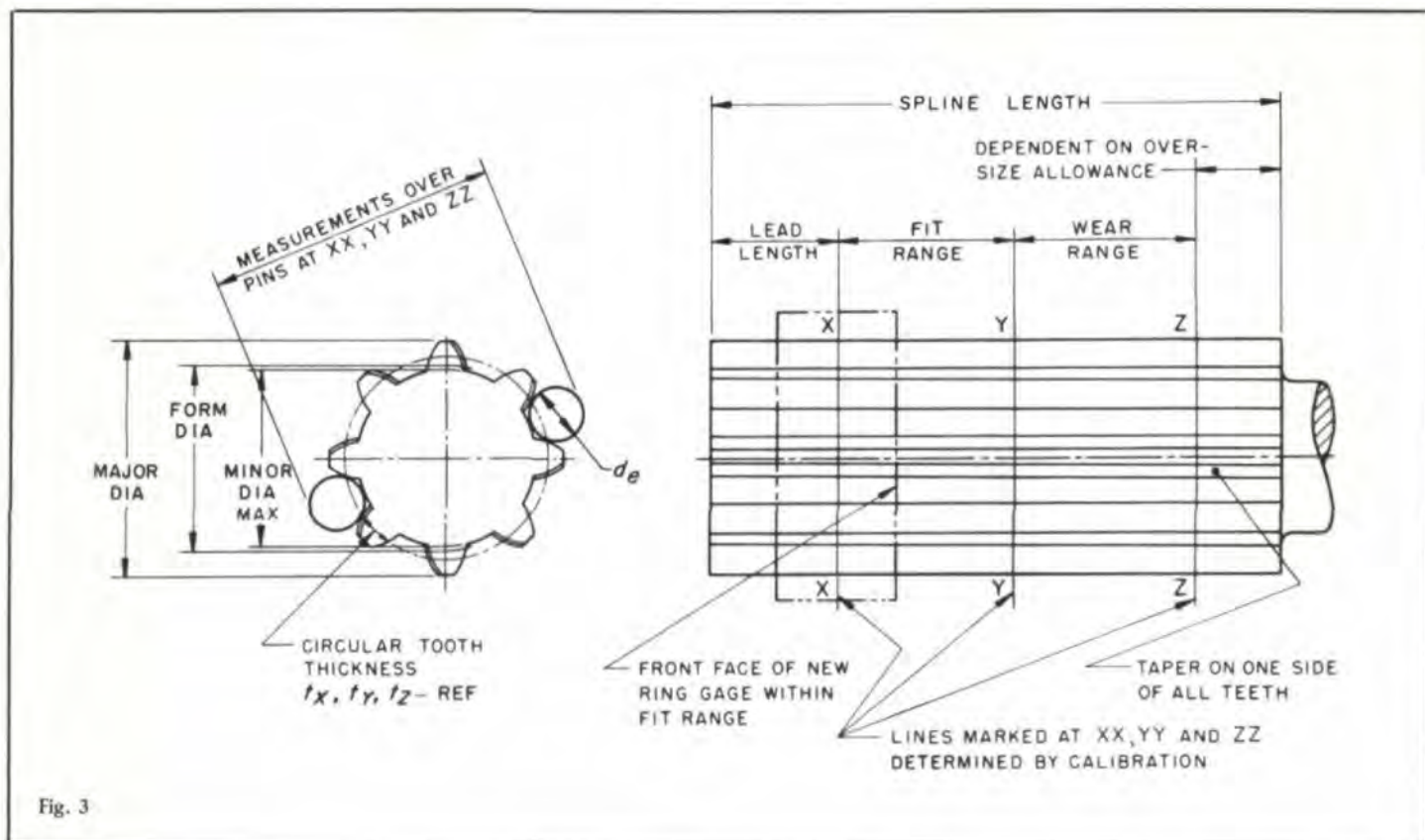

Fig. 3

spline into the gage, especially when the fit between part and gage is close. If the spline won't enter fully, it is classed as an oversize reject. The "NO GO", because of its limited teeth and usual non entry situation, is more difficult to apply. Along with the difficulty in use, industry standards for this check are not consistent for either the number of places, which constitute a reject, nor for the force required to attain engagement. It is obvious that the use of "GO" and "NO GO" gages is tedious and labor and skill intensive.

Another element necessary to consider is gage wear. Allowances are made for this in making a new gage. Periodically active gages must be monitored for size. This can be done with measurement between pins, but usually a tapered master plug is used. (See Fig. 3). Etched lines along the plug indicate the fit or wear range. This means splines accepted by a worn gage may be rejected by a new one.

Ring gage tolerances are planned to absorb no more than 25% of the product tolerance. In practice, by way of a sampling of actual gages in active use, it was found that the measured accuracy

of "GO" gages can absorb a higher percentage.

For many years, the span or block measurement system for sizing involute gears and splines has been used. It is a simple procedure using a micrometer and reads over a group of teeth. (See Fig. 4). It is independent from the outside diameter variations or runout. A normal line to any tangent on an involute will lie in a plane tangent to the base cylinder. Therefore, two parallel span flanges will contact opposing tooth profiles similar to the measurement of a cylinder. This means the micrometer can be rocked, reading from base diameter to tip for a constant reading, in either direction. As in measuring a cylinder, the check is independent of runout.

A dynamic means for span measurement has been developed to duplicate the principle of a flange micrometer on block measurement. This requires a support for the piece part on its journals in a roller cradle or between centers. The work piece is approached by a rotating spindle which is pivoted for access. The spindle carries a pair of helical checking discs which engage the work piece over an ap-

propriate span of teeth as shown in Fig. 5. One disc is fixed axially on the drive spindle and is keyed to rotate the spline on its axis. The second disc is also keyed to the drive spindle, but is free to slide axially on the spindle. The sliding disc is directed by a spring to close over the span of spline teeth. As the work piece is rotated through one full revolution, the axial movement of the second disc senses the variation in spans progressively tooth by tooth. A displacement transducer records the axial movement of the sensing disc and provides a continuous signal, which includes a succession of span readings equal to the number of teeth in the part.

The number of teeth in the span for 30 degree PA splines falls in approximately a 60 degree sector, or for a 40 tooth part the span is 7 teeth. In the check of this part, 40, 7 tooth span readings will occur.

The output of the displacement transducer may be displayed on an oscilloscope, recorded on a strip chart or made to trigger indicator lights. (See Fig. 6). This shows a strip chart trace for span measurement of a typical spline. Each

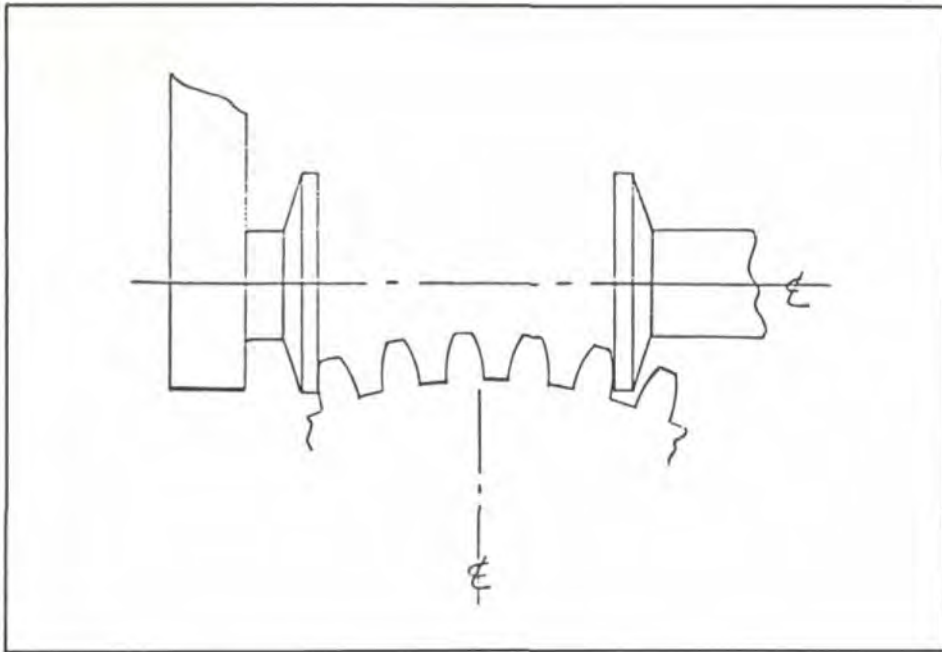

Fig. 4

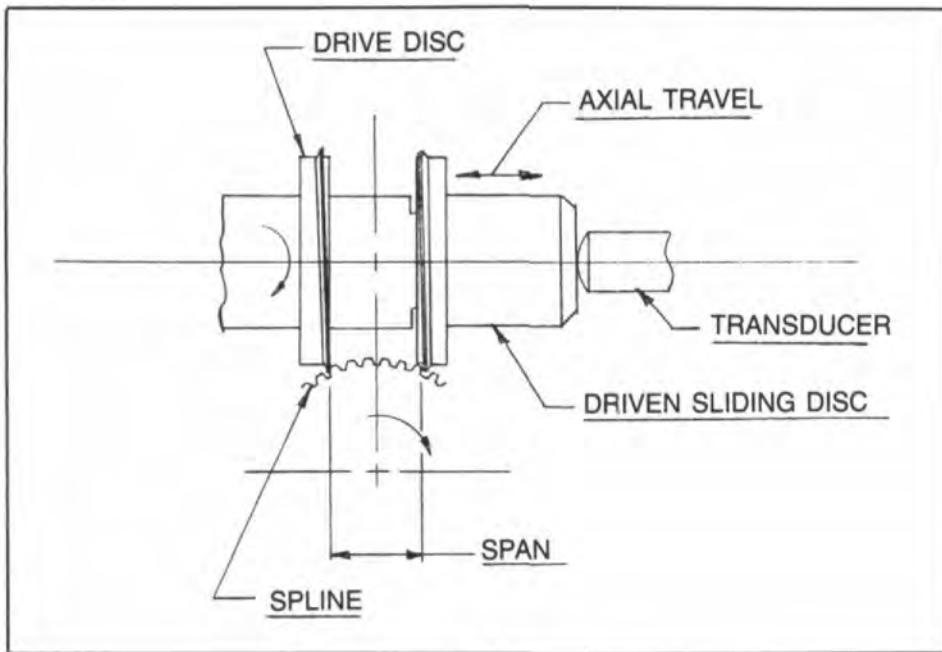

Fig. 5

amplitude excursion from one peak to the next represents one span measurement. The 45 teeth in the spline are represented by 45 peak to peak span measurements over 8 teeth. One revolution of the part is obvious as the cycle repeats again after 45 peaks. The sinusoidal record for this particular spline is an indication of piece part ovality caused by heat treat distortion of a thin walled, tubular part.

To relate the span measurement signal to the "GO" - "NO GO" acceptance limits, the following parameters have been established. To determine an over-size condition, the maximum span reading plus the span variation in one revolution of the part are compared to established preset limits. For determination of an undersized spline the maximum span is compared to an established lower limit. In addition, span variation



**JEIL Automatic Gear Hobbing Machines, available in 2 sizes:**

<b>MODEL JDP-2</b>	<b>MODEL JDP-3</b>
26" Gear Diameter	32" Gear Diameter
D.P.4	D.P.3
<b>\$46,500</b>	<b>\$64,200</b>

Differential, Automatic two-cut hobbing cycle, Hydraulic support lift, Hydraulic crowning attachment, Automatic hob shifting.



**PICCO Universal Chamfering and Gear Rounding Machine**

MAX. MODULE 15  
MAX. DIA. 24"  
MODEL K15 **\$47,800**



**HOBLOH High Speed Small Gear Hobbing Machine**

120-12 D.P.  
Dia. 0.118 - 6.299"  
Prices start at **\$44,200**



**ILLIES AMERICA, INC.**  
5420 Newport Drive  
Rolling Meadows, IL 60008  
312-577-1144



is compared to an established limit. The size category determination, that is comparison of the measured span to limits is accomplished in an electronic logic package accompanying the mechanical inspection unit. The package incorporates digital displays of the greatest span measured and span variation as well as indicator lights which classify the inspected spline as OVERSIZE, GOOD, or UNDERSIZE. Setting masters are used to calibrate the instrument.

In the development of this span measurement, three specific production splined shafts were studied thoroughly. (See Fig. 7). They were: turbine shaft, sun gear shaft and oil pump shaft. The turbine and oil pump were rack rolled, the sun shaft was broached.

With the assistance of an independent quality laboratory, samples of the three production shafts and their ring gages for inspection were accurately measured for various elements. The results of some of the most important measured piece part elements are shown in TABLE I. The results of corresponding measurements made on the "GO" composite ring gages for these piece parts are shown in TABLE II.

The tabular information indicates the variability within the parts and the gages. From the data it can be seen that a large portion of the fit tolerance was used by the ring gage itself. In the case of the oil pump shaft, the accuracy of the production piece parts was as good or better than the inspection ring gage.

A correlation study of span measurement to determine spline size, using ring gages, for the 40 tooth turbine shaft is shown in Fig. 8. It reveals a rather good correlation, and in this case, the gray area is only a few tenth thousandths inches wide.

The span measurement system provides a measurement for size determination; whereas, the ring gages give a somewhat subjective size determination. In practice, it has been found that from the measurement resulting from the span system, ring gage fit predictions can be made.

Splines determined to be "GOOD" by the span system, and new, unworn ring gages may be "REJECT", as determined by worn, but still within tolerance ring gages. This disparity can be troublesome to a supplier of splines and a user of

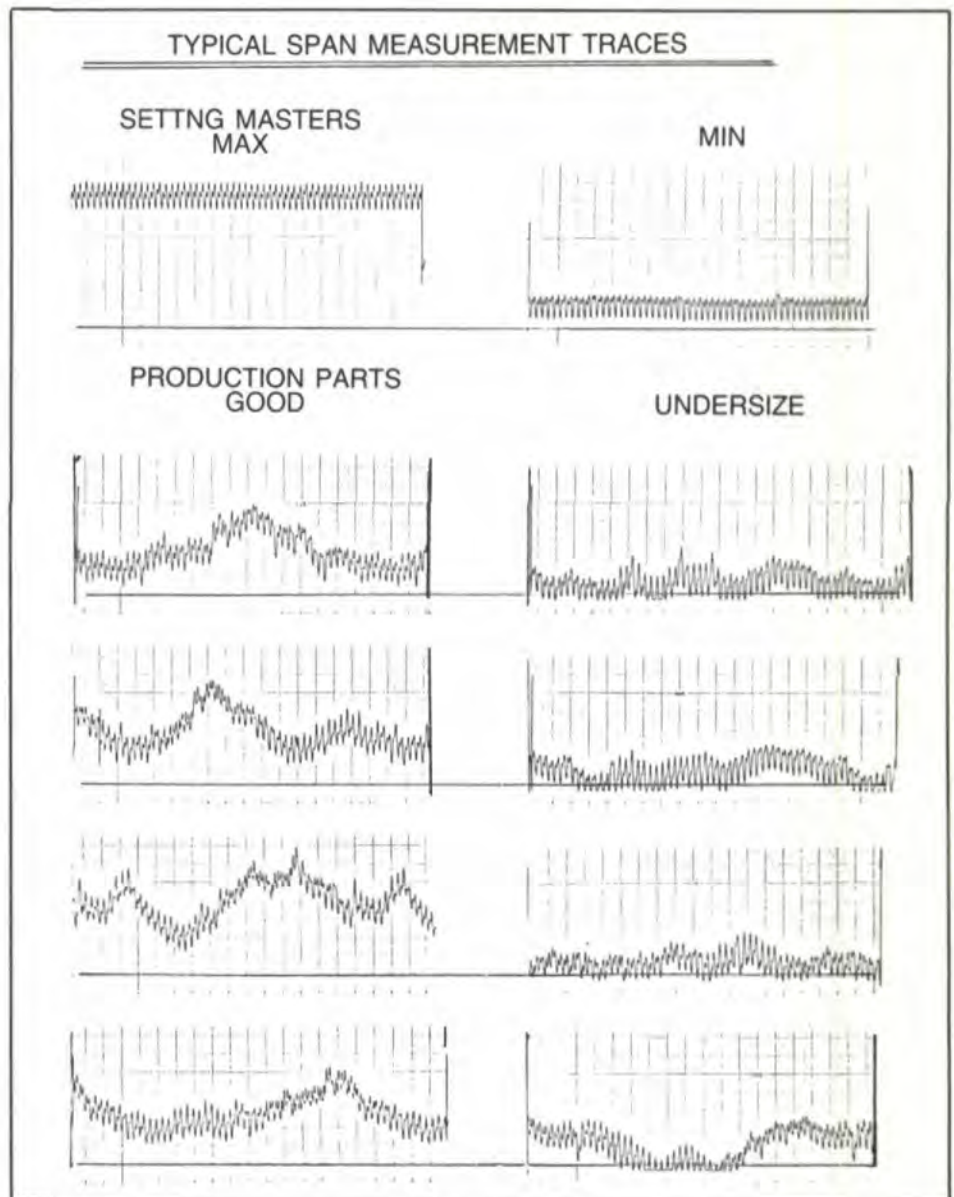

Fig. 6

TABLE 1  
Measurement of Splined Product

Element Range in inches	Turbine	Sun	Oil Pump
1) Total Index Variation	.001 — .0029	.0036 — .01158	.000810 — .001670
2) Pitch Variation	.00034 — .00087	.00074 — .00190	.000290 — .000830
3) Spacing Variation	.00032 — .00111	.00063 — .00197	.000300 — .001090

TABLE 2  
Measurement of Ring Gages  
("GO" Composites)

Element Range in inches	Turbine	Sun	Oil Pump
1) Total Index Variation	.00136 — .00162	.00175 — .00215	.00155 — .00165
2) Pitch Variation	.00021 — .00025	.00075 — .00100	.00037 — .00040
3) Spacing Variation	.00024 — .00037	.00143 — .00176	.00029 — .00038



Fig. 7

splines both checking parts with ring gages, but one using a worn set and one using a new set. The span system precludes this possibility.

Further application of the span measurement system to a broader range of products will eventually determine the limit of this process. In the future, ring gages may be merely a periodic check of size correlation much as tapered plug gages are a periodic check of ring gages for wear today.

*Portions of this paper have been presented at the Fall 1984 Technical Conferences for AGMA & SME.*

E-2 ON READER REPLY CARD

