

# Gear Blank Tuning

Andy Gale, Paul Langlois and Owen Harris

## Introduction

The design of gear blanks or flanges has traditionally been driven by weight reduction. Recently innovative companies have started to use the gear blank design to tune the system dynamics to reduce gear whine.

This is used successfully for EV and HEV applications where noise is critical, as there is no or less internal combustion (IC) noise to mask gear whine, and speeds and gear tooth passing frequencies are higher and can interact strongly with the gear blank dynamics.

There is potential that the inclusion of circumferential holes in gear blanks can lead to further NVH improvements. Traditional methods for modeling are adapted in this paper in order to optimize the design of these holes, while a new simulation method is introduced that can more realistically capture the modulation effects of the gear blank as it rotates.

The simulation methods presented here are implemented within SMT's MASTA software, a CAE tool for drivetrain design, analysis and optimization.

## EV Drivetrain Model

In order to test the simulation methods presented here, a realistic single-speed, two-stage helical EV drivetrain model is used (Fig.1). The analysis model consists of an FE-based model where shafts are considered as Timoshenko beam elements, and gear mesh and bearings as bespoke non-linear contact models.

In this case the first-stage wheel blank and transfer shaft is represented via stiffness and mass matrices determined via dynamic reduction from the full FE component (Fig. 2) in order to fully capture the gears' mode shapes and deflection under load.

The motor and gearbox casing are also represented in full FE in order to compare the dynamic response of the casing for various gear blank designs under the specified loading condition.

The loading conditions and main model parameters are displayed (Table 1). For this design, the maximum input speed is 14,000 rpm, but it should be noted the trend for recently emerging and future EV's are for input speeds up to 20,000 rpm or higher. The input torque of 50 Nm represents light loading at low speed, and is typical of the vehicle's torque at high speed, meaning it gives a representative loading condition over the vehicle's speed range.

## Gear Blank Tuning Methods

**Traditional methods for modeling.** For analysis of gear whine, a frequency domain methodology well documented by Steyer et. al (Ref. 1) is chosen. This method applies the static gear transmission error (TE) at each gear mesh as a relative displacement input. The compliance at each side of the gear mesh, which can be considered as a measure of how much motion each gear mesh generates per unit force applied, can be calculated by applying a unit harmonic force in the line of action and

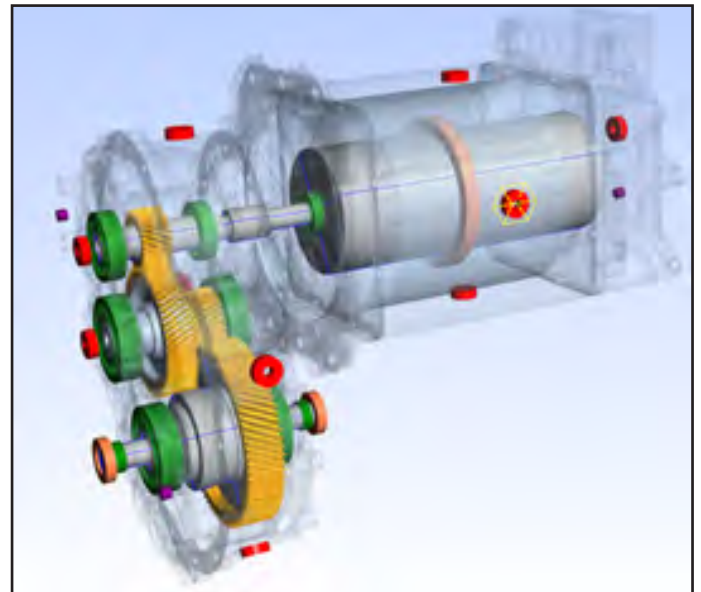

Figure 1 EV drivetrain model.

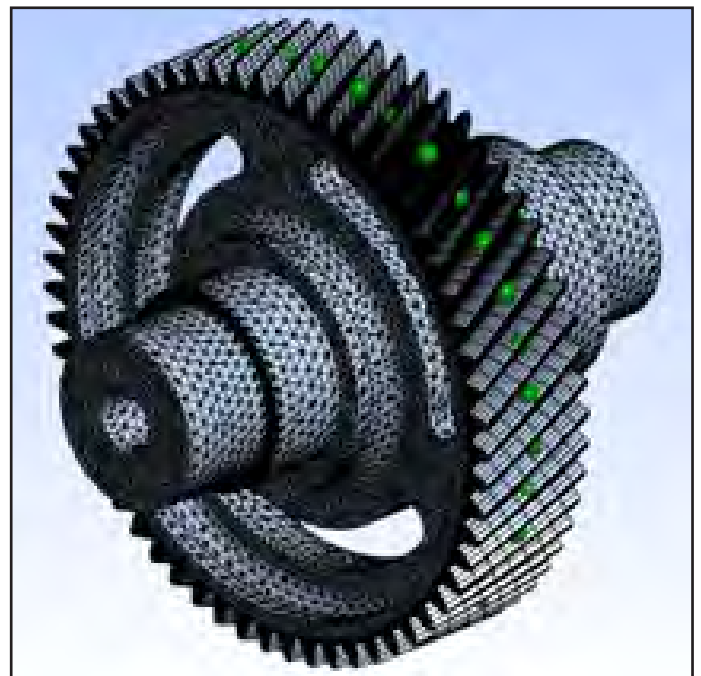

Figure 2 First-stage wheel blank and transfer shaft FE.

Table 1 EV drivetrain loading conditions and model parameters

Loading Conditions	
Input speed	14,000 rpm
Input torque	50 Nm
Model Parameters	
Overall gear ratio	6.535:1

calculating the resulting harmonic displacement. The pinion and wheel compliances are then summed together in order to give the total compliance. The dynamic mesh stiffness is then calculated as the inverse of the total compliance.

The dynamic gear mesh force is then derived as the product of the TE and dynamic stiffness for a given harmonic of the TE and applied to the model to give the dynamic response of the whole system.

Where:

$$C_{mesh}(\omega) = C_p(\omega) + C_w(\omega)$$

$$D(\omega) = (C_{mesh}(\omega))^{-1}$$

$$F_i(\omega) = D(\omega) \delta_i$$

$C_{p,w}(\omega)$  - Is the dynamic compliance in the line of action at the mesh, at the pinion (p) and wheel (w) sides, at frequency  $\omega$

$C_{mesh}(\omega)$  - Is the total compliance at the mesh in the line of action

$D(\omega)$  - Is the dynamic mesh stiffness in the line of action

$F(\omega)$  - Is the dynamic mesh force for the  $i$ th harmonic of the TE

$\delta_i$  - Is the  $i$ th harmonic of the TE, transformed normal to the flank, normal to the helix

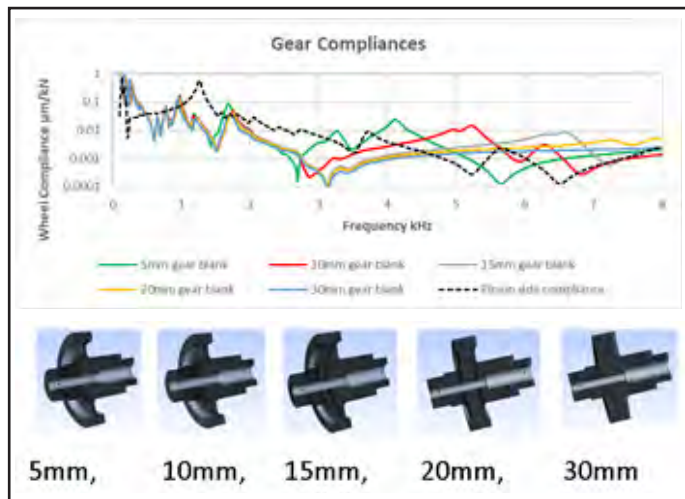

Figure 3 Compliance result for varying web thickness.

By studying the compliances, one can tune the dynamics at the gear mesh and avoid high gear mesh forces in the operating range (Refs. 2–3). This can be seen in Figure 3, where thicker blanks have modes at higher frequencies, reaching outside the operating range for blanks with a web thickness larger than 15 mm.

The characteristic gear blank mode shape causing a peak in compliance at approximately 5 kHz for the 10 mm gear blank is shown (Fig. 4).

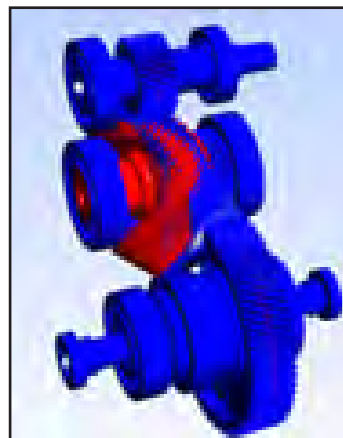

Figure 4 Gear blank 'potato chip' mode.

It can also be seen however that thicker blanks have a lower compliance, and hence give higher dynamic mesh forces within the operating range (Fig 5).

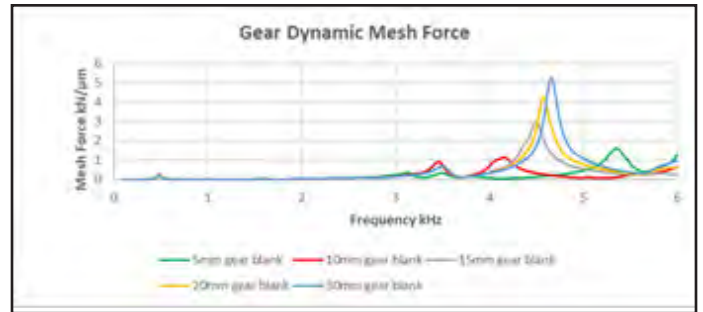

Figure 5 Dynamic mesh force result for varying web thickness.

A careful design of the blank must therefore be used to tune the driveline dynamics and reduce mesh forces. The methodology described here is in the frequency domain leading to fast analysis times and is thus well suited for optimization purposes.

**Axisymmetric optimization.** In order to optimize the gear blank design for NVH improvements, one must consider the system as a whole, taking into account both the dynamic mesh force at the gear mesh and the transfer path from gear mesh to components such as bearings, housing and mounts; the dynamic response at a particular location being equal to the multiplication of both these factors.

In a previous study (Ref. 3) the airborne sound power of the casing was chosen as the key metric for optimization, giving a good indication for the overall airborne noise radiated from the casing due to excitation at the gear mesh.

An automatic optimization method was utilized, whereby the gear web and rim thickness were modified within defined bounds and meshed, then the static deflections and misalignments were calculated in order to calculate the static TE. The harmonic response to the TE, in this case the sound power

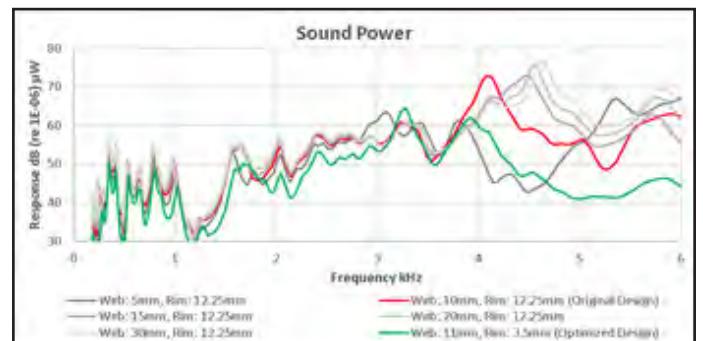

Figure 6 Axisymmetric optimization casing sound power result.

result, was then determined. This method led to a gear blank design that has over a 10 dB decrease in sound power (green) compared to the baseline (red) (Fig. 6).

It should be noted that other design targets, such as durability, should be considered in any optimization approach, and while the optimized design seen here may give large improvements in terms of NVH, the reduced rim thickness does lead to higher misalignments and stresses at the gear mesh. A trade-off of improvements must therefore be decided upon when choosing a gear blank design.

**Gear blank with holes preliminary optimization using harmonic analysis.** To further optimize the gear blank design for NVH, three circumferential, elongated holes were added to the previously optimized axisymmetric design (Fig. 7). The design was similar to that used in industry (Refs. 4–5) where the holes are intended to cause modulation in the mass and stiffness at the tooth contact as the gear rotates, meaning the vibration level of the gear doesn't reach full resonance before the mass and stiffness changes.

For simulation of this effect, it is suggested that a time domain solution is needed that can consider the fluctuating components of the mass and stiffness as the gear rotates (Ref. 4).

While this approach is valid and has been shown to give good correlation to test data, a full MBD time domain solution does not currently lead itself to fast simulation times and so would be impractical for the purposes of design optimization.

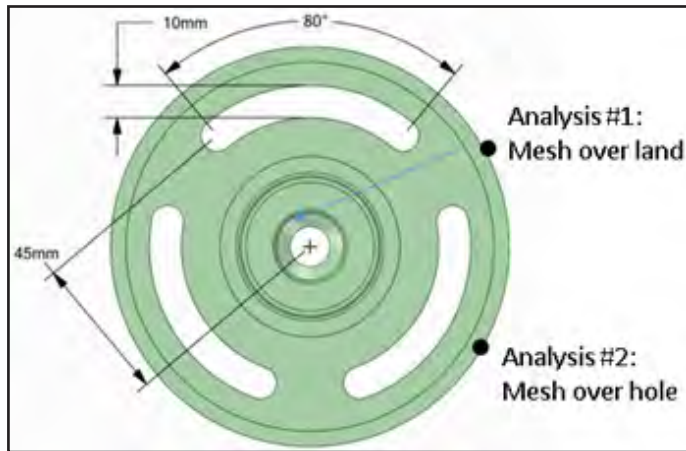

Figure 7 Baseline gear blank design with holes.

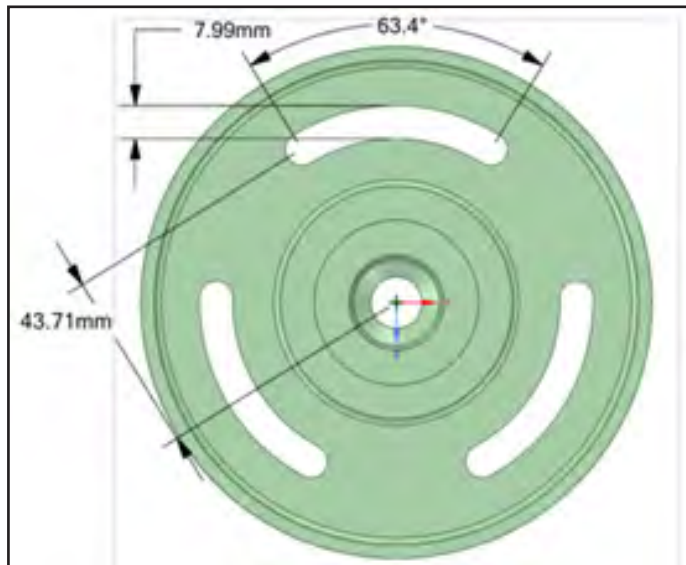

Figure 8 Optimized gear blank design with holes.

The optimization method thus utilized was similar to that used in the axisymmetric study, the main difference being that an analysis was performed with the gear mesh over the land and the gear mesh over the hole on each design iteration (Fig. 7), leading to two dynamic response results of airborne sound power for each design.

An optimization algorithm was employed where the design parameters (hole width, center radius, sweep angle, fillet radius and gear blank web and rim thickness) were modified in order to fulfil two design objectives of minimizing the maximum sound power result — both over the land and over the hole. The algorithm converged to a set of optimal designs shown (Fig. 9; otherwise known as a pareto front), where a trade-off between the two objectives had to be analyzed to pick the optimized design. Designs that had large misalignments were discounted from the analysis (colored in yellow).

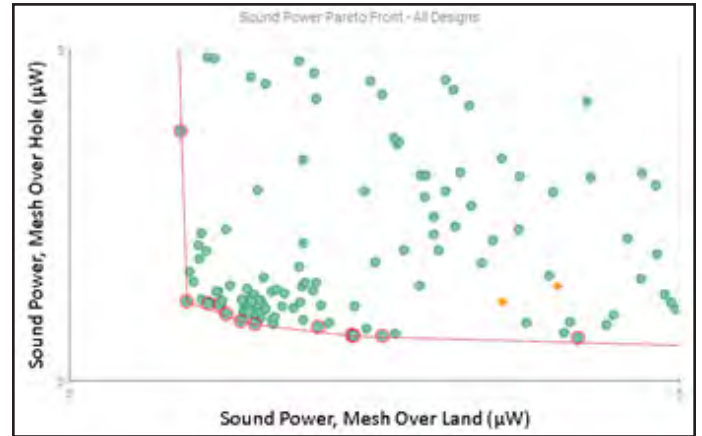

Figure 9 Pareto front of designs.

The chosen optimized design shown (Fig. 8) had the same web and rim thickness as the baseline design — but with a smaller hole width and sweep radius. This design gave a lower maximum sound power across the operating range, both when the gear mesh was over the land or over the hole, compared to the baseline design with holes. As can be seen (Fig. 10), it also gave a lower maximum sound power at both rotation angles compared to the previously optimized axisymmetric gear blank; units are given here in absolute scale for clarity.

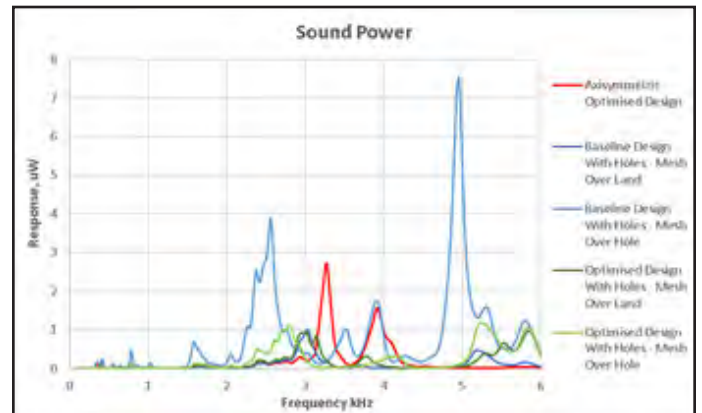

Figure 10 Gear blank with holes optimization sound power result.

### Dynamic Solution for Modulation

**Proposed dynamic solution for modulation.** While the method utilized in the gear blank with holes study leads to fast simulation times and is ideal for optimization purposes, the critical phenomenon of resonance disruption from the holes is not captured and hence any design that is proposed for manufacture should be checked with a more advanced simulation that can



capture this phenomenon.

A solution is proposed that utilizes the speed of a linearized modal model at a number of slow timescale steps, e.g. — hole passing angles, and a transient linear time-stepping solution of the modal model on a fast timescale, such as tooth passing. As a time-stepping simulation it does capture the resonance disruption mechanism.

The method is faster than a traditional time-stepping approach while retaining most of the simulation accuracy, meaning it can be useful as a tool for comparing a small number of gear blank designs or verifying the results of an optimization.

**Dynamic response results comparison.** To more accurately compare the NVH response of the axisymmetric design to the baseline design with holes, the new dynamic solution method was employed, focusing on any potential improvements to the two areas of large sound power response identified in the axisymmetric optimized design at approximately 3.3 and 3.9 kHz (Fig. 10). Acceleration response on 12 accelerometers distributed around the casing (Fig. 1) was used to compare the designs.

The TE amplitude at the gear mesh order of the axisymmetric and baseline design with holes was found to be quite similar at 0.0592  $\mu\text{m}$  and 0.0628  $\mu\text{m}$ , respectively. However, the gear blank with holes experiences a modulation in TE as it rotates, leading to sidebands around the gear mesh order. To negate this effect a unit TE of 1  $\mu\text{m}$  was applied as the excitation at the first-stage gear mesh order in both simulations.

Results from the new dynamic solution can be seen (Figs. 11 and 12). It is clear that the locations of the two large peaks in sound power response seen in the axisymmetric optimized design in Figure 10 correspond with the locations of the two large peaks in accelerometer response in Figure 11; this demonstrates the validity of comparing accelerometer response for any potential NVH improvements from the design — with holes, in this case.

Comparing the results from Figs. 11 and 12, there is a marked reduction in accelerometer response in the gear blank with holes at the problem areas of 3.3 and 3.9 kHz; showing this design is expected to lead to overall NVH improvements compared to the axisymmetric design.

**Proximity analysis.** Although the gear blank design with holes has shown an improved NVH response at the gear mesh order, the sideband content and its relative difference in frequency from the mesh order should also be considered.

The prominence ratio (PR) method is a way of ascertaining if a discrete tone will be heard above the levels of critical bands on either side of the critical band containing the discrete tone.

As can be seen (Fig. 13), +3 / -3 sidebands arising from the hole modulation all fall within critical band B, which is centered on the gear mesh order. This means the content of energy within these sidebands will add to the content of energy within the main mesh order and be heard by a listener as a single prominent tone. Any energy that falls within critical bands A or C, however, such as the +6/-6 sidebands, have the potential to help mask the prominence of a discrete tone in critical band B.

Future work is planned to investigate this sideband structure in more detail.

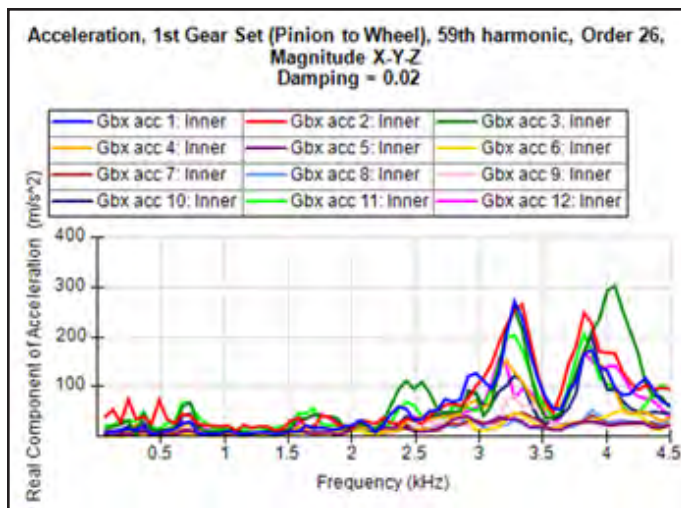

Figure 11 New dynamic solution result; response of housing accelerometers at gear mesh order with axisymmetric optimized gear blank design with no holes.

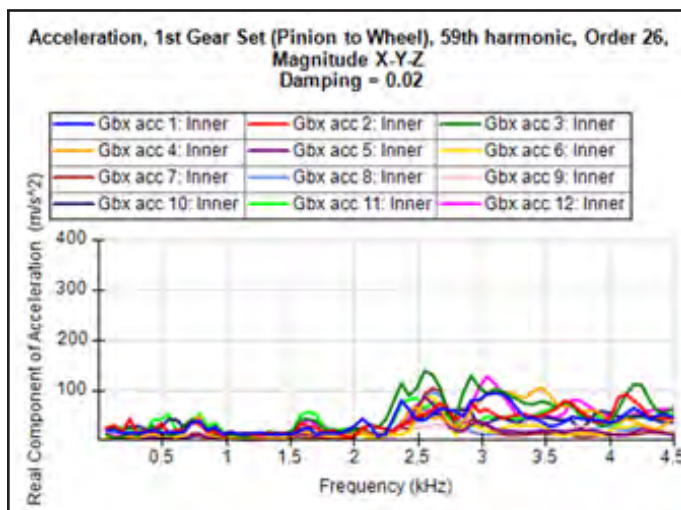

Figure 12 New dynamic solution result; response of housing accelerometers at gear mesh order with baseline gear blank design with 3 holes.

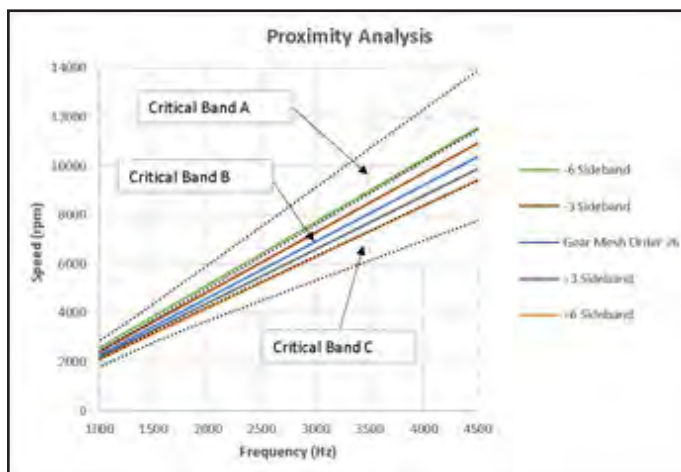

Figure 13 Proximity analysis of gear mesh order and associated sidebands.

## Conclusion

A traditional simulation method has been used to optimize the hole design on a realistic EV drivetrain wheel blank for improved airborne sound power response on the gearbox and motor casing.

A novel dynamic method has then been introduced that verifies the improved NVH response from adding holes; the method being faster than a full time domain solution while retaining good accuracy.

## References

1. Chung, C.H.J., G. Steyer, T. Abe, T. Clapper and C. Shah. "Gear Noise Reduction through Transmission Error control and Gear Blank Dynamic Tuning," SAE Technical Paper 1999-01-1766, 1999.
2. Harris, O. "Electric Vehicle Whine Noise," *JSAE Annual Congress* (Spring), 2019.
3. Harris, O., P. Langlois and A. Gale. "Electric Vehicle Whine Noise — Gear Blank Tuning as an Optimization Option," *Gear Technology*, March/April 2019, pp. 64–73.
4. Asai, Y., T. Nagae and Y. Hirabayashi. "Time Domain NV Simulation with A/T Assy Model by Modal Synthesis Method," SAE Technical Paper 2018-01-0397, 2018 doi:10.4271/2018-01-0397.
5. Furukawa, T., R. Ibaraki, H. Kimura, H. Kondo, M. Watanabe, T. Mizutani, H. Hattori and A. Takaski. "Development of New Hybrid Transaxle for Sub-Compact-Class Vehicles," SAE Technical Paper 2012-01-0623, 2012 doi: 10.4271/2012-01-0623.



**Andy Gale** is a research engineer at SMT. He has a background in mechanical engineering, and has experience in a variety of fields including additive manufacture and NVH. He has recently been leading modal testing research and development at SMT.



**Dr. Paul Langlois** is the software engineering director at SMT. Having worked for SMT for 13 years, he has extensive knowledge of transmission analysis methods and their software implementation. He manages the development of SMT's software products and is a main contributor to many aspects of the technical software. As a member of the BSI MCE/005 committee, Langlois contributes to ISO standards development for cylindrical and bevel gears.



**Dr. Owen Harris**, a graduate of Trinity College Cambridge, has worked in the analysis of transmissions and geared systems for over twenty years. He was instrumental in writing some of the first commercial software codes for housing influence, system modal analysis and gear whine and planetary load sharing. Harris has filled many roles in over ten years working at Smart Manufacturing Technology Ltd. (SMT). He has worked on SMT's state-of-the-art MASTA software, while at the same time being heavily involved in many engineering projects. Harris's current focus is to lead SMT's research department.

