

Not All Good Ideas are Brand New

by Dr.-Ing. Carsten Hünecke,
Head of Mathematic Technical Department Klingenberg

In the March/April issue of *Gear Technology*, the article “Gear Measuring Machine by NDG Method for Gears Ranging from Miniature to Super-Large” was published. The article describes the so-called “Normal Direction Generate Method (NDG)” as a new method for involute tooth profile measurement.

The basic idea is to move the probe not only in the X-axis direction of a measuring machine synchronously

with the gear rotation angle, but also the Y-axis direction in a way that the probe moves along the line of action. This reduces the movement in X-axis direction required for the measurement.

This statement is right, but the idea is not new. There is an old patent in the United States and in Germany from Professor Willy Höfler which describes this idea. The patents were filed in 1988 (U.S. patent No.

4,852,402) and in 1987 (German Patent DE 37 17 166 C2) and later owned by Klingenberg. As described in the article, the probe is moved along the line of action, which is tangential to the base circle. A measuring device using the patented method was the TPF.

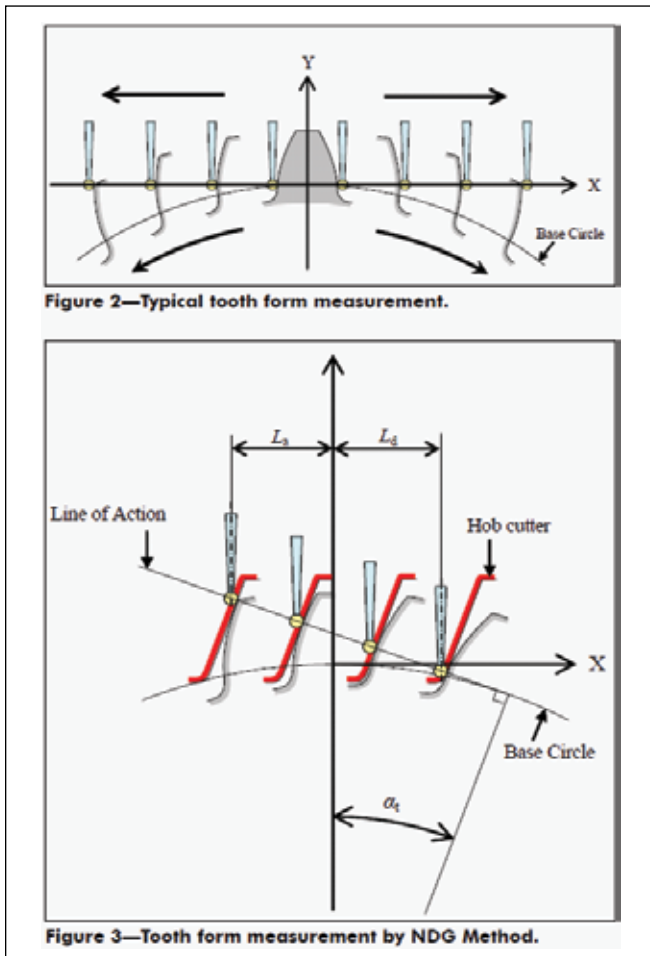

Figure 1—Figures 2 and 3 from the March/April 2011 *Gear Technology* article, “Gear Measuring Machine by NDG Method for Gears Ranging from Miniature to Super-Large.”

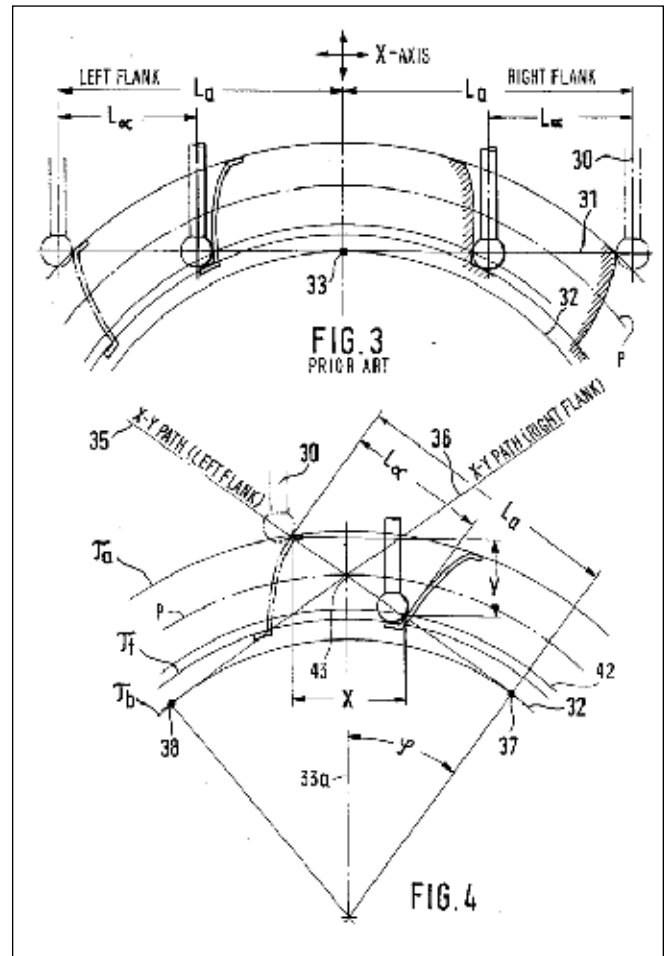

Figure 2—Figures 3 and 4 of the U.S. Patent No. 4,852,402, “Method and Apparatus for Checking or Testing the Profile of Gear Flanks, Particularly of Involute Gears.”