

Local Simulation of the Specific Material Removal Rate for Generating Gear Grinding

Christian Brecher, Fritz Klocke, Markus Brumm, Florian Hübner

Generating gear grinding is one of the most important finishing processes for small and medium-sized gears, its process design often determined by practical knowledge. Therefore a manufacturing simulation with the capability to calculate key values for the process—such as the specific material removal rate—is developed here. Indeed, this paper presents first results of a model for a local analysis of the value. Additionally, an empirical formula—based on a multiple regression model for a global value describing the process—is provided.

Introduction

The hard fine finishing process is generally the last step in the manufacture of cylindrical gears. The most established processes are the generating gear grinding and discontinuous profile grinding (Ref. 1). Similar to conventional grinding processes—e.g., external cylindrical grinding or surface grinding—the process design for grinding tooth flanks is based on characteristic values that can be determined for a particular process due to its geometrical conditions. Among these characteristic values are the volume of cut material V'_w , the un-deformed chip thickness h_{cu} and the specific material removal rate Q'_w (Refs 2–3).

Figure 1 shows the processes of surface-peripheral-traverse grinding, profile gear grinding and generating gear grinding. While the contact between tool and workpiece is considered constant for one stroke with the conventional grinding process of surface-peripheral-traverse grinding and profile gear grinding, the contact varies for generating gear grinding.

For conventional fine finishing processes, these values can be calculated analytically from geometrical and kinematic data with little effort (Ref. 4). Calculating these characteristic values for gear grinding processes is significantly more elaborate and has not to date been standardized (Refs. 2–3; 5). This is due to the significantly more complex geometry of tool and gear for both continuous generating gear grinding as well as discontinuous profile grinding. For generating gear grinding, the calculation is made par-

ticularly difficult by the more complex kinematic relations. At this writing, there is no standardized calculating methodology to generate characteristic values for continuous generating gear grinding, nor for discontinuous profile grinding, on which basis the grinding process can be designed (Refs. 2-3 and 6).

State of the Art

Gear grinding processes are among the kinematically and geometrically most complex grinding processes, with high requirements for accuracy in dimension as well as in parts' properties of the surface zone (Refs. 1, (6–7)). Therefore, designing the processes poses a considerable challenge; generally, the design process is supported by using characteristic values, since a design based entirely on empirical studies is time- and cost-consuming. Characteristic values are

generated in order to determine cause-and-effect relationships of a characteristic function that do not depend on the chosen grinding process. In this way different processes and their conduct can be compared to one another (Ref. 7) and an optimal manufacturing strategy for a specific part can be chosen. One of these characteristic values is the specific material removal rate Q'_w , which cannot be determined metrologically. This value can be represented by models or determined indirectly by analyzing empirically determined correlations to measurable characteristics or damages (e.g. grinding burns) of the part (Refs. 2–3). This characteristic value is explained and defined in the following sections—initially for conventional grinding processes and subsequently for gear grinding processes as well.

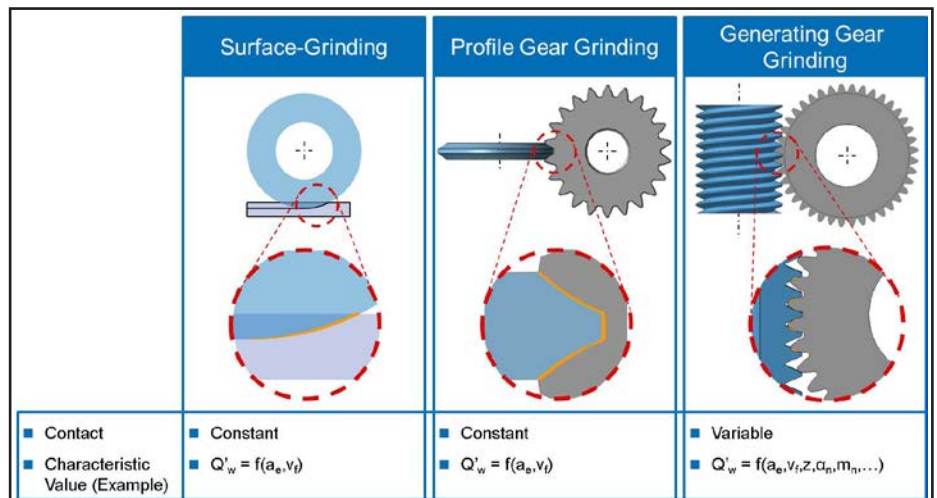

Figure 1 Comparison of conventional grinding processes with gear grinding processes

Specific Material Removal Rate for Conventional Grinding Processes

As the part geometry and process kinematics are easy to follow, surface-peripheral-traverse grinding is chosen as an example for calculating the specific material removal rate for conventional grinding processes. The process is applied for grinding large surfaces and its schematic is depicted in Figure 2. The grinding wheel is advanced radially along the feed

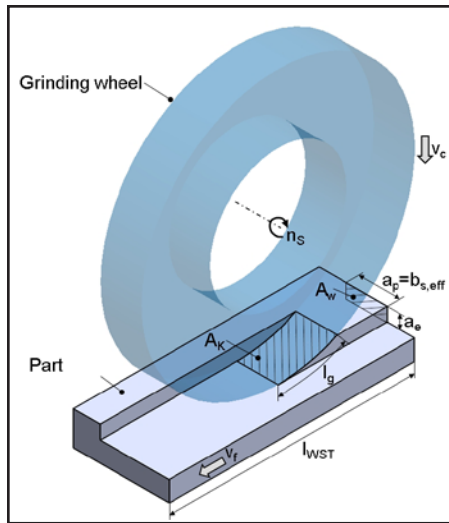

Figure 2 Characteristic values for surface-peripheral-traverse grinding (7), (3)

a_e and perpendicularly to the worktable in order to grind the desired stock.

The tool is typically fed axially by the contact width a_p outside the part. The contact width correlates to the effective grinding wheel width $b_{s,eff}$ due to the process. Generally the worktable with the clamped part is moved with the feed velocity v_f . The grinding wheel rotates with the set number of rotations n_s — which results in circumferential velocity v_c . Should v_c and v_f align, the process is referred to as climb grinding; if not, as conventional grinding (Ref. 7).

According to Equation 1, the material removal rate can be referenced to the grinding wheel width in order to compare different processes with respect to their productivity (Refs. 6-7).

$$Q'_w = a_e \cdot v_f \quad (1)$$

Besides geometrical characteristic values, grinding forces, power and energy can be consulted for assessing and designing grinding processes (Ref. 7). Werner (Refs. 8–9) developed an initial

calculating methodology for determining the normal force F'_n that is based both on the presented characteristic value chip cross-section A_{cu} and the kinematic number of cutting edges n_{kin} (Eq. 2).

$$F'_n = \int_0^{l_k} k \cdot A_{cu}(l) \cdot N_{kin}(l) dl \quad (2)$$

In addition to forces, grinding temperatures play a decisive role in assessing and designing processes. Until now, few studies have been conducted that examined the change and influence of grinding temperatures. However, the influence on the structure by inducing energy into the part is an essential quality criterion for functionality (Ref. 10).

According to Stimpel (Ref. 3), it applies to all presented characteristic values for ideal contacts, and that the contact geometry:

- shows stationary behavior during the course of the process (except for start and end of contact)
- can be considered constant for the contact width a_p of the tool

Specific Material Removal Rate for Gear Grinding Processes

Generally, characteristic values used for gear grinding processes mainly conform to characteristic values of conventional grinding processes. Calculating the characteristic values is based on similar formulas which parameters are adapted to the particular process by geometrical considerations (Refs. 2-3, 6). This approximation, however, is hardly — or not at all — admissible, due to the presented requirements of a contact geometry that is temporally stationary, as well as constant along the contact width.

For continuous generating gear grinding, a temporally constant behavior of the contact between tool and part is not a factor. Defining the contact width a_p proves to be more of a challenge for continuous generating gear grinding than for conventional grinding or profile gear grinding processes, since, due to the complex kinematics, the contacting conditions cannot be described in simple terms (Ref. 6). As the resulting velocities of the profile are neither local nor temporally constant, nor can the contact width be constant (Ref. 11). Theoretically, the contact width conforms with the width of the chip cross-section, which is perpendicu-

lar to the resulting feed velocity (Refs. 4 and 6). The contact width, however, is temporally inconstant, thus the characteristic values for these processes vary along the profile and the tooth width.

Despite these restraints, formulas have been developed based on the algorithms of conventional grinding processes, with which help the specific material removal rate for continuous generating gear grinding can be calculated in approximation (Refs. 2 and 6). Based on geometric considerations, Türich generated formulas for an average specific material removal rate (Eq. 3) as well as for calculating Q'_w locally (Eq. 4).

$$Q'_{w,m} = \frac{v_f \cdot z \cdot a_e \cdot \sin \alpha_n \cdot \cos \beta \cdot (d_a^2 - d_{ff}^2)}{2 \cdot d_b \cdot \cos \gamma_0} \quad (3)$$

$$Q'_{w,lok} = \frac{2 \cdot v_f \cdot \pi \cdot \Delta s \cdot \sin \alpha_n \cdot \cos \beta \cdot \sqrt{d_f^2 - d_b^2}}{d_0 \cdot \sqrt{1 - \left(\frac{2 \cdot \Delta s \cdot \sin \alpha_n - d_0}{d_0} \right)^2}} \quad (4)$$

Further algorithms for calculating the specific material removal rate have been established by Schriefer (Ref. 6). A general formula (Eq. 5), as well as an extended formula (Eq. 6), have been developed. Both approaches — according to Schriefer and Türich — provide significantly differing results. For all presented approaches, the scope of application is limited, as the formulas have not been explicitly defined for an application to gear flanks; root grinding processes are not covered.

$$Q'_w = a_w \cdot v_{res} \cdot \sin \alpha_n \quad (5)$$

$$Q'_w = a_w \cdot \sin \alpha_n \cdot \frac{f_{res} \cdot n_0}{\cos \beta} \quad (6)$$

The desired stock — as well as the motion of the tool for generating the final slot geometry — has been greatly simplified for the presented formulas. Furthermore, a limited regard to influences on the specific material removal rate has been paid in these approaches. Therefore no standardized approach for determining one or more characteristic values for the process design of continuous generating gear grinding and discontinuous profile grinding yet exists.

Objective and Approach

The state of the art shows that significant differences exist between determining characteristic values for convention-

al grinding processes and gear grinding processes. And yet the characteristic values — as established for conventional grinding processes — are transferred to generating and profile gear grinding. But in many cases this is not effective, so that designing the process has required expert knowledge or an extensive series of tests (Refs. 1-3; 6).

For the approaches presented here, the stock conditions are especially simplified and the contact conditions for continuous generating gear grinding are disregarded. It therefore becomes an objective of the project to develop a methodology that allows determining characteristic values for generating and profile grinding processes. This methodology is to lead to a manageable formula that supports the design process that can provide results to a machine operator within a reasonably short time. Furthermore, a local analysis of the characteristic values has to be developed for a detailed analysis of critical process designs.

In the following sections, a local approach for calculating the specific material removal rate is presented. This model analyzes a single process in detail for optimizing the process design; thus the local approach needs a time-consuming simulation of the process.

An approach for determining the specific material removal rate based on a regression model follows. This approach provides an empirical formula without having to use the previous local approach, making it much easier to handle and less time-consuming.

Local Approach for Calculating the Specific Material Removal Rate for Generating Gear Grinding

From the state of the art it can be gathered that a number of approaches exist to define and determine characteristic values for processes. Existing approaches for defining characteristic values for continuous generation grinding use approximate calculations that rely on kinematic and geometrical values. Schriefer approximated the generating gear grinding process by using a limited number of external grinding processes and derives characteristic values (Refs. 5-6). Türich and Stimpel calculate a theoretical contacting plane and derive approximation formulas as well (Eqs. 29), only in part regarding

the conditions of engagement (Eqs. 2-3). Therefore these calculation approaches cannot be applied without restrictions.

Stimpel developed a first numerical approach that allows the calculation of characteristic values for generating gear grinding (Ref. 3). However, it calls for a detailed knowledge of the algorithms or the possession of the developed program. Therefore this approach is not generally available.

In recent years, a model has been developed with the assistance of the WZL Gear Research Circle and the DFG (German Research Foundation) in order to analyze gear grinding processes (Ref. 11). An overview of this model is presented (Fig. 3). For this model, the used tool and the given slot geometry is approximated by a triangular mesh. Both geometries can be calculated by the program or imported from external data.

Additionally, the machine kinematics can be represented by choosing the

respective process — generating or profile gear grinding — beforehand. For internally calculating tool, part and kinematics, the geometrical values for unambiguously describing the parts are necessary. Furthermore, the grinding stock, cutting velocity and axial feeds can be specified. By using this approach, it is possible to set up a batch operation in order to calculate a high number of different gear designs automatically, with the help of the model within a short period of time.

As a result, the model provides the finished part as well as the contacting geometry for the rolling positions during the process (Fig. 4). Ideal contacting geometries are calculated that are analyzed for discrete rolling positions. With that, it is possible to reproduce root finishing alongside flank finishing. From the calculated contacting geometry, process parameters such as the characteristic value of the local contracting volume $V_{k,lok}$ or the contact thickness $h_{k,lok}$ can be

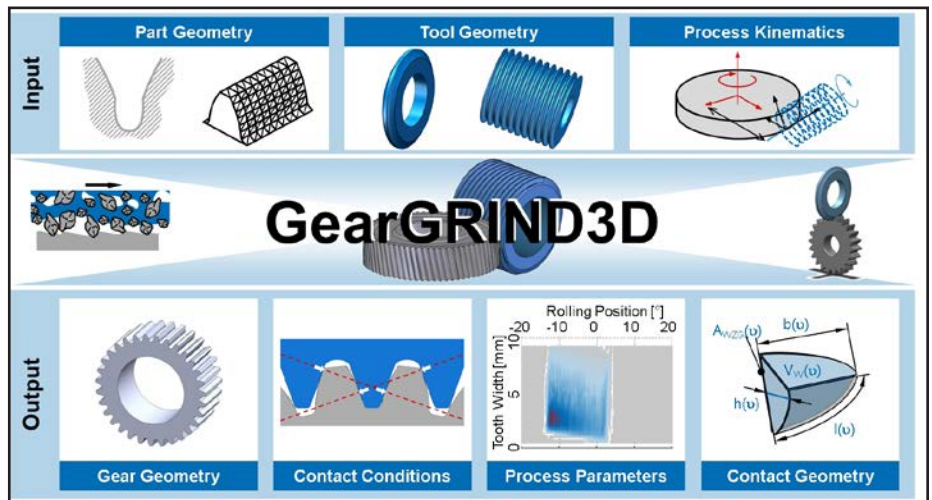

Figure 3 Scope of the manufacturing analysis GearGRIND3D

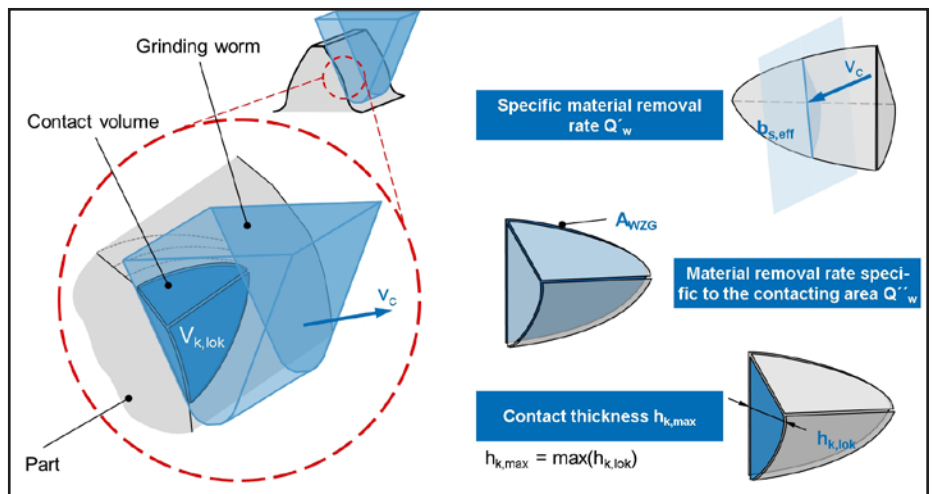

Figure 4 Numerical approach for a local calculation of the specific material removal rate

determined.

Besides the specific material removal rate Q'_w , Salje (Ref. 4) defines the material removal rate specific to the contacting area Q''_w as a further characteristic value, since the contacting conditions between grinding tool and workpiece cannot be considered constant, as is the case for the generating gear grinding process. For this the volume is divided by a common contacting plane between tool and part. This value can be calculated by means of the presented methodology as well (Fig. 4, center/right). The following discussion is limited to the calculation of the specific material removal rate Q'_w :

Since besides the contacting geometry, the direction of the resulting cutting velocity is known for any rolling position, the contacting geometry can be characterized by a plane that is perpendicular to the cutting velocity in the center of gravity of the contacting volume (Fig. 4, top/right). Thus the effective width of the

grinding worm $b_{s,eff}$ can be determined for a discrete rolling position of a continuous grinding process. If the volume $V_{k,lok}$ is divided by the effective width of the grinding wheel and the increment of time Δt , in which the contacting volume is cut, the specific material removal rate according to Equation 7 results. The increment of time Δt is determined by the given increment of the rolling angle Δv , the ratio i , as well as the number of revolutions of the tool n_0 , (Eq. 8).

$$Q'_{w,lok} = \frac{V_{k,lok}}{b_{s,eff} \cdot \Delta t} \quad (7)$$

$$\Delta t = \frac{\Delta v \cdot i}{2 \cdot \pi \cdot n_0} \quad (8)$$

Thus the specific material removal rate can be calculated locally on the flank for discrete rolling positions with the help of the methodology implemented in GEARGRIND3D.

An example for the displayed results is

given (Fig. 5). On the left, the data of the grinding worm and process parameters are listed. For this calculation, a helical gear applied in a wind turbine serves as example.

The vertical axis represents the axial position of the grinding worm, the horizontal axis the position on the profile of the workpiece. The leading flank is ground from the tip to the root, the other flank in the opposite direction.

For the leading flank, the maximum value of the specific material removal rate occurs at the tip during the beginning of the process. The maximum for the entire grinding process occurs at the trailing flank, also at the beginning of the process at the tip of the simulated tooth. In general, Q'_w has higher values at the beginning of the process and during the manufacturing of the tip. The reason for this is found in the curvature of the involute that leads to a higher removed volume at the tip.

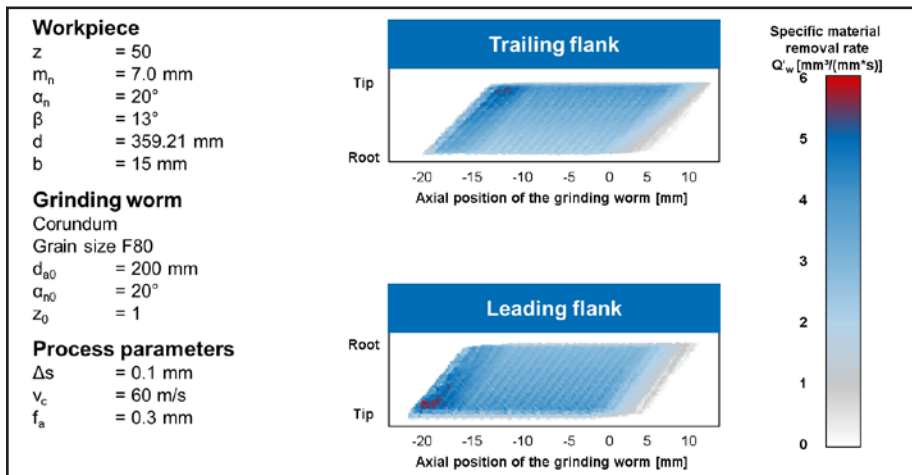

Figure 5 Local calculation of the specific material removal rate

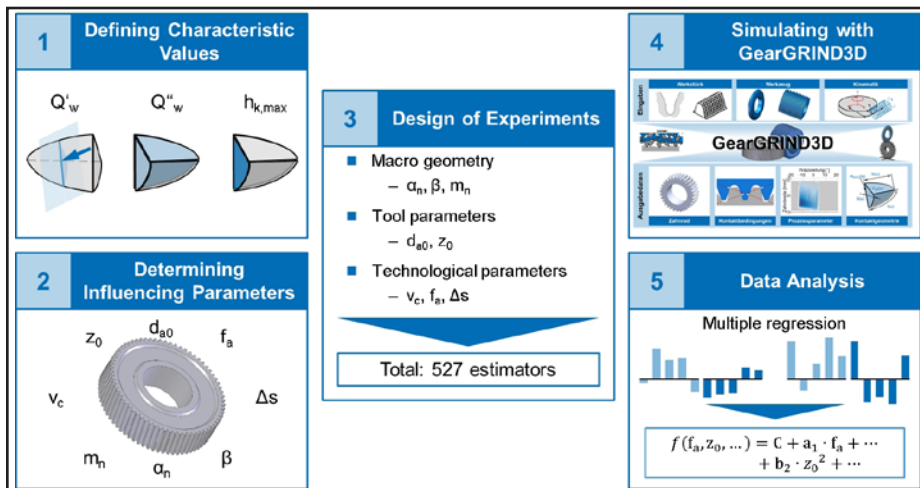

Figure 6 Empirical approach for a global calculation of the specific material removal rate

Global Approach for Calculating Specific Material Removal Rate for Generating Gear Grinding

Besides the presented simulative approach, a preferably simple formula for determining a mean specific material removal rate is to be developed. It can be determined with the help of the previously presented approach, since, due to its flexibility, it can be applied to any generating and profile grinding process. So it is possible to calculate a multitude of variants with the help of the numeric approach GEARGRIND3D. Based on the results, a regression model can be generated that provides a formula for the desired characteristic value.

Figure 6 shows the necessary steps for setting up an empirical model. As a first step, the general calculation of the specific material removal rate is defined. Subsequently, relevant influencing parameters are determined. This occurs on the basis of previous formulas and regarding the process parameters of generating gear grinding. According to Schriefer, Türich and Stimpel, influencing factors on the characteristic value of the specific material removal rate Q'_w are the grinding worm outside diameter d_{a0} , number of threads z_0 , cutting velocity v_c , axial feed f_a , grinding stock Δs , pressure angle α_n , normal module m_n and helix

angle β .

Subsequently, by using a DoE approach, the number of variants that must be examined is reduced, allowing the simulation to be conducted within a reasonable time. If the investigations had been conducted on a full factorial scale, it would result in $4^8 = 65,536$ estimators; the effort would lead to a calculating time of several weeks. On the other hand, parameters cannot be varied independently from one another, since not every combination leads to an operational gear. Variations of the module m_n , pressure angle α_n and helix angle β make the automated design of trial gears especially more difficult. Therefore, as a first step the process parameters f_a , Δs and v_c — as well as the tool parameters d_{a0} and z_0 — are varied with the help of a D-optimal design of experiment (Fig. 6, left). By applying a D-optimal design of experiment the number of estimators can be reduced from $4^5 = 1,024$ to 31 trials. In order to vary m_n , β and α_n as well, the design of experiment is applied to 17 example gears. It is therefore assured that all examined 527 trial points are operational gears for which the specific material removal rate Q'_w can be calculated by means of the model presented previously in this paper.

The evaluation of the data occurs with the help of a multiple regression analysis. For this, a quadratic transfer function for the individual factors is determined in advance; thus the regression analysis is conducted by means of a quadratic basic function. Interdependencies between the individual factors are left disregarded in order to limit the complexity of the approach. The result is a lower coefficient of determination R^2 as well as the prognosis factor Q^2 than if the interdependencies had been considered. A lower coefficient of determination signifies a higher variance of the values — or that there is no relation between the values. A Q^2 that is too small means that the model will change for new tests. An able model for describing the influences is given — if Q^2 as well as R^2 are above 0.9.

By introducing a transformation of the target values, R^2 and Q^2 can be further improved. This so-called Power or Box Cox Transformation is an established instrument and generally used for taking the logarithm of wear characteristics.

The results of the regression analysis are Equations 9 and 10:

$$Q'_w = e^x \tag{9}$$

$$x = 10.278 + 0.275 \cdot z_0 - 0.006 \cdot d_{a0} + 0.018 \cdot v_c - 12.275 \cdot f_a^2 + 12.058 \cdot f_a - 22.5 \cdot \pi \cdot \Delta s^2 + 12.371 \cdot \Delta s - 0.069 \cdot m_n^2 + 0.911 \cdot m_n + 0.001 \cdot \beta^2 - 0.003 \cdot \beta \tag{10}$$

The coefficient of determination R^2 for the conducted analyses is 0.934. The value for Q^2 is with 0.933 on the same level. Thus, a good correlation between the formula and the simulation can be determined for examining the specific material removal rate.

Summary and Outlook

Due to the limited number of scientific investigations, gear grinding processes are currently designed and optimized based on experience. For this reason, the transfer of characteristic values — as they have been applied to conventional grinding processes for many years onto continuous generation grinding and discontinuous profile grinding — is pursued. However, no standardized methods or formulas which are able to calculate these characteristic values exist. Therefore, investigations have been initiated aimed at developing a standardized methodology for determining the specific material removal rate Q'_w . This methodology is supposed to calculate Q'_w locally, as well as by means of a manageable formula."

The specific material removal rate is calculated locally with the help of the process simulation program *GEARGRIND3D* for continuous generating gear grinding. Subsequently a design of experiments is defined and a regression model is set up for the characteristic value. Finally, the formula for attaining the specific material removal rate Q'_w is presented. The quality of the presented formula regarding the spread of the values and the robustness regarding additional testing points is good.

Since the presented characteristic values cannot be recorded metrologically, the determined values and formulas must be verified by other means. Furthermore, there are no boundary values that would lead to part, tool or machine damage if transgressed. These values can be determined by grinding trials, for instance, in which an occurrence of grinding burns is the matter of investigation. If an influ-

ence of the surface zone due to process conditions should appear for a certain amount of the characteristic value, a boundary value can be found that would lead to flank damage if transgressed. Another option for defining boundary values is the investigation of the grinding worm's wear that has to be correlated to the determined characteristic value. 

Acknowledgments. *The authors gratefully acknowledge financial support by the German Research Foundation (DFG) [Project Number KL500/94-1] for the achievement of the project results. For the software-based achievement of simulative results the authors gratefully acknowledge the financial support for the software development of GearGRIND3D by the WZL Gear Research Circle.*

References

1. Bausch, T. Innovative Zahnradfertigung: Verfahren und Maschinen zur kostengünstigen Herstellung von Stirnrädern mit hoher Qualität. 3rd ed.: Expert Verlag, Renningen-Malmsheim, 2006.
2. Türich, A. Werkzeugprofilgenerierung beim Wälzschleifen. Dissertation, Universität Hannover, 2002.
3. Stimpel, F. Technologische Kenngrößen für das kontinuierliche Wälzschleifen von Evolventenverzahnungen. Dissertation, Universität Hannover, 2009.
4. Salje, E.: Begriffe der Schleif- und Konditioniertechnik: Vulkan-Verl, Essen, 1991.
5. Meijboom, L. Erhöhung der Wirtschaftlichkeit beim Wälzschleifen durch verbesserung des Zerspanvorganges. Dissertation, RWTH Aachen, 1979.
6. Schriefer, H; W. Thyssen, W. Wirz, G. Scacchi and M. Gretler. Reishauer Wälzschleifen: Eigenverlag Reishauer, Walisellen, 2008.
7. Klocke, F. and W. König. *Fertigungsverfahren 2: Schleifen, Honen, Läppen*, Springer, Berlin, New York, 2005.
8. Werner, G. "Kinematik und Mechanik des Schleifprozesses," Dissertation, RWTH Aachen, 1971.
9. Werner, G. Konzept und Technologische Grundlagen zur Adaptiven Prozessoptimierung des Außenrundschleifens, Habilitation, RWTH Aachen, 1973.
10. Fritz Klocke; Markus Brumm; Jan Reimann, 2013: Modeling of Surface Zone Influences in Generating Gear Grinding. *Procedia CIRP* 8(2013):21–26.
11. Brecher C; Brumm M; Hübner F: Manufacturing simulation for generating-gear grinding of large-module gears. In: Höhn B. International Conference on Gears: Europe invites the world. VDI Berichte 2199, VDI Verlag, München, 2013.

Prof. Dr.-Ing. Christian Brecher

has since 2004 served as Ordinary Professor for Machine Tools at the Laboratory for Machine Tools and Production Engineering (WZL) of the RWTH Aachen, as well as director of the Department for Production Machines at the Fraunhofer Institute for Production Technology IPT. Upon receipt of his engineering degree he began his career as a research assistant and later as team leader in the Department for Machine Investigation and Evaluation at the WZL. From 1999–2001 Brecher worked as a senior engineer with responsibility for machine tools and director (2001–2003) for development and construction at the DS Technologie Werkzeugmaschinenbau GmbH, Mönchengladbach. Brecher has received numerous honors and awards, the Springorum Commemorative Coin and the Borchers Medal of the RWTH Aachen among them.



Markus Brumm, a RWTH graduate with a degree in mechanical engineering, began his career in 2005 as a research assistant in gear investigation at the Laboratory for Machine Tools and Production Engineering (WZL) of the RWTH Aachen. He subsequently became that group's team leader in 2010.



Prof. Dr.-Ing. Dr.-Ing. E.H. h.c. Dr. h.c. Fritz Klocke

studied manufacturing engineering at the TU Berlin, was a research fellow there at the Institute for Machine Tools and manufacturing Technology until 1981, and then as head engineer until 1984, receiving his engineering doctorate in 1982. Klocke worked in industry from 1984 until 1994 at Ernst Winter & Sohn in Hamburg. On January 1, 1995 he was called to the RWTH Aachen as Professor of Manufacturing Engineering Technology and has since then been Chair of Manufacturing Technology, co-director of the WZL Laboratory for Machine Tools & Production Engineering at the RWTH Aachen and head of the Fraunhofer Institute for Production Technology IPT in Aachen. Klocke was awarded the Otto-Kienzle Memorial Coin in 1985 by the Manufacturing Engineering University Group. The title, "Dr.-Ing. E.H.," was bestowed upon Klocke by the University of Hannover in 2006 for his outstanding achievements in science, his efforts in the industrial implementation of a broad range of manufacturing techniques, and for his commitment to numerous scientific committees. The title "Dr. h. c." was awarded him in 2009 by the University of Thessaloniki and in 2010 by Keio University in Tokyo for his achievements in production science, his engagement in international cooperation, and his benefits as a teacher and supervising tutor of student engineers.



Dipl.-Ing. Florian Hübner

has since 2012 served at Aachen University of Technology, Germany as Team Leader and Research Assistant—Group Gear Design and Manufacturing Simulation—focusing on manufacturing simulation for generating gear grinding. Previously—i.e., 2005 – 2012—Hübner devoted his attention to the study of mechanical engineering, also at Aachen.



GEAR CUTTING TOOLS 

MADE IN SWITZERLAND



GEAREXPO 2015
THE DRIVE TECHNOLOGY SHOW™
BOOTH #2417



SCHNYDER US Distributor
HANIK CORPORATION

GEAR CUTTING SOLUTIONS
60 YEARS OF TOP TECHNOLOGY

PHONE 630-595-7333
FAX 630-595-7343
www.hanikcorp.com email: hanikcorp@aol.com

ph: 011-41-32-344-0400 • fax: 011-41-32-344-0404 • www.schnyder.com • mail@schnyder.com

Spiral Bevel Gears

- Spiral & straight bevel gear manufacturing.
- Commercial to aircraft quality gearing.
- Spur, helical, splined shafts, internal & external, shaved & ground gears.
- Spiral bevel grinding.
- Midwest Transmissions & Reducers.
- ISO compliant.



Midwest Gear & Tool, Inc.
15700 Common Rd., Roseville, MI 48066
Tel: 586.779.1300 midwestgear@sbcglobal.net

