

# Induction Hardening of Gears and Critical Components

## Part II

Dr.Valery Rudnev

### Management Summary

Induction hardening is a heat treating technique that can be used to selectively harden portions of a gear, such as the flanks, roots and tips of teeth, providing improved hardness, wear resistance and contact fatigue strength without affecting the metallurgy of the core and other parts of the component that don't require change. This article provides an overview of the process and special considerations for heat treating gears. Part I, which was published in the September/October 2008 issue, covered gear materials, desired microstructure, coil design and tooth-by-tooth induction hardening (For the online version, visit <http://www.geartechnology.com/issues/0908/>). Part II covers spin hardening and various heating concepts used with it.

### Gear Spin Hardening (Using Encircling Inductors)

Spin hardening is the most popular induction gear hardening approach, and it is particularly appropriate for gears having fine- and medium-size teeth (Figure 8). Gears are rotated during heating to ensure an even distribution of energy. Single-turn or multi-turn inductors that encircle the whole gear can be used (Ref. 1).

When applying encircling coils, there are five parameters that play major roles in obtaining the required hardness pattern: frequency, power, cycle time, coil geometry and quenching conditions. Figure 9 illustrates a diversity of induction hardening patterns that were obtained with variations in heat time, frequency and power (Ref. 1).

As a rule, when it is necessary to harden only the tooth tips, a higher frequency and high power density should be applied

continued



Figure 8—Examples of gears that use spin-hardening techniques.



Figure 9—Diversity of hardness patterns obtained with induction spin hardening.

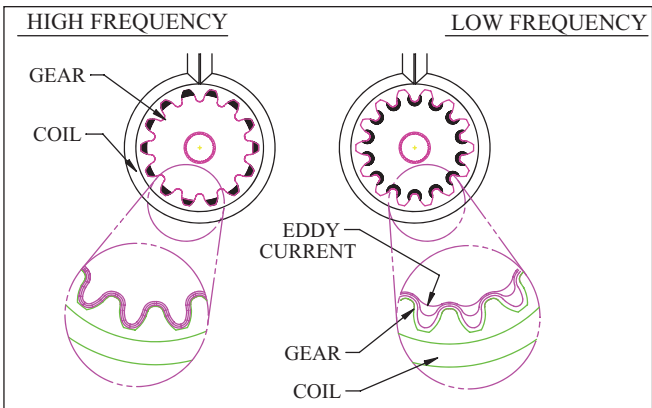

Figure 10—Frequency influence on eddy current flow within the gear when using an encircling inductor.

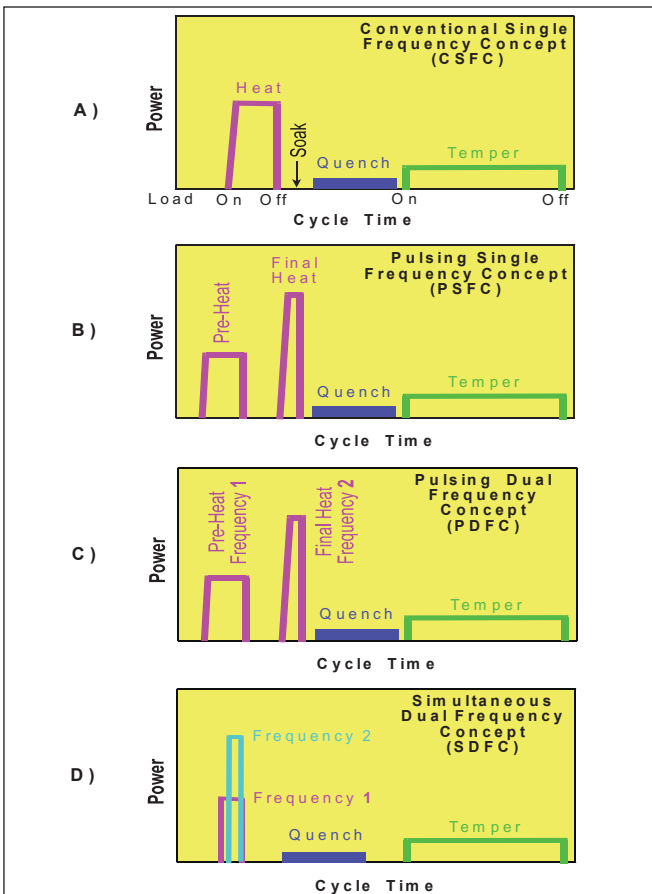

Figure 11—Induction gear hardening concepts: A) CSFC; B) PSFC; C) PDFC; D) SDFC.

in combination with short heat time (Fig. 10, left). To harden the tooth roots, use a lower frequency (Fig. 10, right). A high power density generally gives a shallow pattern, while a low power density will produce a deep pattern with wide transition zones. Hardness pattern uniformity and repeatability depend strongly on the relative positions of gear and induction coil and the ability to maintain the gear concentric to the coil.

### Gear Quenching

Induction hardening is a two-step process: heating and quenching. Both stages are important. There are three ways to quench gears in spin hardening applications (Ref. 1):

- Submerge the gear in a quench tank. This technique is particularly applicable for large gears.
- Quench “in place” using an integrated spray quench. Small- and medium-size gears are usually quenched using this technique.
- Use a separate, concentric spray-quench block (quenchring) located below the inductor.

Note that the widely published, classical cooling curves that represent the three stages of quenching—vapor blanket, boiling and convection heat transfer—cannot be directly applied in spray quenching (Ref. 7). Due to the nature of spray quenching, the first two stages are greatly suppressed. At the same time, cooling during the convection stage is more severe.

Tooth geometry and rotation speed are other factors that have a pronounced effect on quench flow and cooling severity during gear quenching.

It is also important to avoid both eccentricity of the inductor and quench system relative to the gear and gear wobbling. Even with gear rotation, gear wobbling will cause a specific part of the gear to be hotter during heating, because regardless of rotation it will always be closer to the coil. Besides non-uniform heating, wobbling also causes uneven quenching, leading to additional hardness non-uniformity and gear shape distortion.

It has been reported that more favorable compressive stresses within the tooth root were achieved with the gear spin hardening technique than with the “tooth-by-tooth” or “gap-by-gap” approaches.

### Heating Concepts

There are four popular heating concepts used for the induction spin hardening of gears that employ encircling-type coils (Fig. 11): the conventional single-frequency (CSFC), pulsing single-frequency (PSFC), pulsing dual-frequency (PDFC) and simultaneous dual-frequency (SDFC) concepts (Refs. 1-4, 8). All four modes can apply either a single-shot or scanning approach. The choice of heating concept depends upon the application and equipment cost.

**Conventional single-frequency concept (CSFC).** The conventional single frequency concept (Fig. 11a) is typically used for hardening gears with medium and small teeth. Often with this technique, the tips of teeth are through hardened. As an example, Figure 12 shows an induction gear-hardening machine that applies this concept. The gear being heat treated

in this application is an automotive transmission component with helical teeth on the inside diameter (ID) and large teeth on the outside diameter (OD) for a parking brake. Both the inside diameter and outside diameter require hardening (Figure 12). The hardening of the inside diameter gear teeth requires a higher frequency than the outside diameter. Therefore, a frequency of 10 kHz was chosen for OD heating and 200 kHz was chosen for ID heating. After heat is off, quenchant is applied to the hot gear in place; that is, no repositioning is required. This practically instantaneous quench provides a consistent metallurgical response. Quenching reduces the gear temperature to the quenchant temperature or temperature suitable for gear handling. Gears are conveyed to the machine, where a cam-operated robot then transfers them to the hardening station.

Parts are monitored at each station and accepted or rejected based on all the major process factors that affect gear quality. This includes energy input into the part, quench flow rate, temperature, quench pressure and heat time. An advanced control/monitoring system verifies all machine settings to provide confidence in the quality of processing for each individual gear. Precise control of the hardening operations and optimized coil design minimize gear distortion and provide the desirable residual stresses in the finished gear. The hardened gear is inspected and moved to the next operation.

Although the conventional single-frequency concept (CSFC) is primarily suitable for small and medium size gears, there are cases when this concept can be successfully used for large gears as well. As an example, Figure 13 shows an induction machine for hardening large gears. A multi-turn encircling inductor is used for hardening gears with a major diameter of 27.6" (701 mm), root diameter of 24.3" (617 mm) and thickness of 3.125" (79 mm). In this case, it was in the customer's best interest to harden and temper gears using the same coil and power supply. In other cases it might not be the best solution.

Quite often, in order to prevent problems such as pitting, spalling, tooth fatigue and endurance, it is required to harden the contour of the gear (contour hardening). In some cases, this can be a difficult task for CSFC due to the difference in current density (heat source) distribution and heat transfer conditions within a gear tooth. Two main factors complicate the task of obtaining the contour hardness profile using the CSFC approach. The first factor is that with encircling-type coils, the root area does not have as good of an electromagnetic coupling with the inductor compared to the coupling at the gear tip. Therefore, it is more difficult to induce energy into the gear root. Second, there is a significant heat sink located under the gear root (below the base circle, Figure 10).

**Pulsing single-frequency concept (PSFC).** In order to overcome these difficulties and to be able to meet customer specifications, the pulsing single-frequency concept (PSFC) was developed (Figure 11b). In many cases, PSFC allows the user to avoid the shortcomings of CSFC and obtain a

continued



Figure 12—Induction hardening of an automotive transmission component with smaller, helical teeth on the ID and large teeth on the OD.



Figure 13—A multi-turn encircling inductor for hardening large gears.

pattern close to a contour hardening profile. Pulsing provides the desirable heat flow towards the root of the gear without noticeable overheating of the tooth tip. A well-defined, crisp, hardened profile that follows the gear contour can be obtained using high power density at the final heating stage.

An induction machine can be designed to provide gear contour heat treatment (including preheating, final heating,

quenching and tempering) with the same coil using one high-frequency power supply. Figure 11b illustrates the process cycle with moderate power preheat, soaking stage, short high-power final heat and quench followed by low-power heat for temper.

Preheating ensures a reasonable heated depth at the roots of the gear, enabling the attainment of the desired

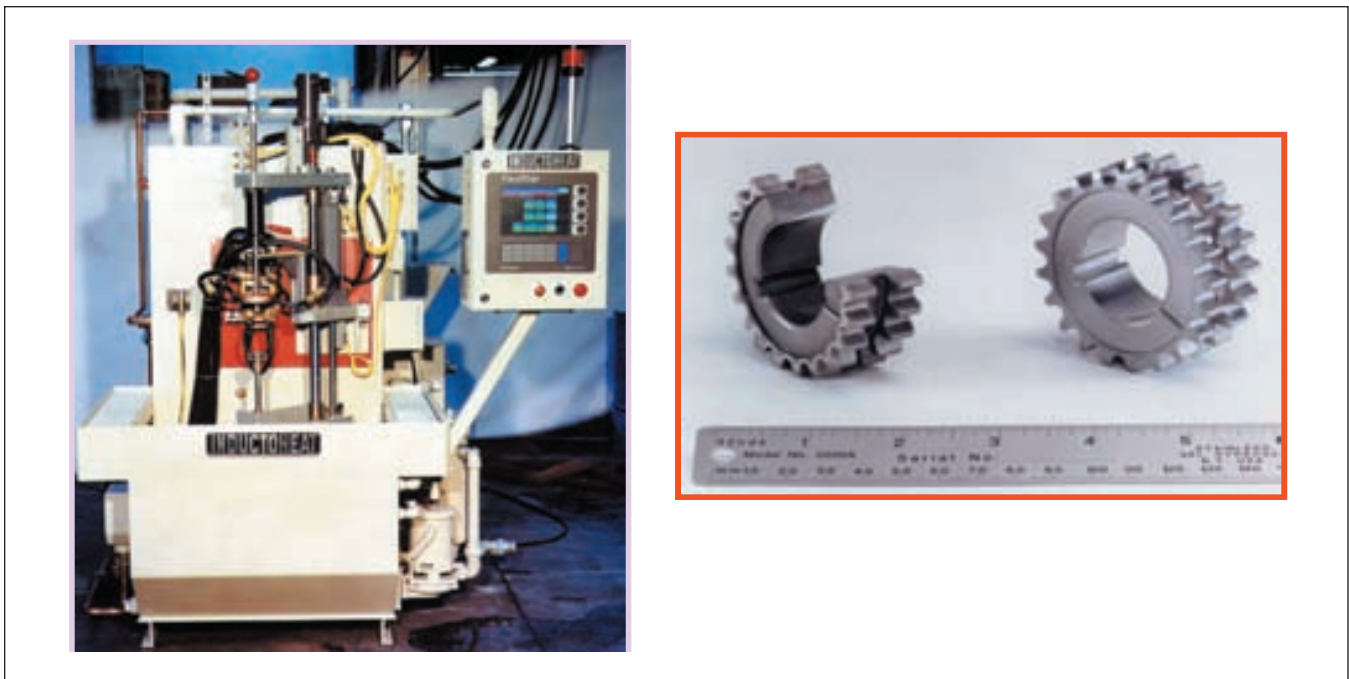

Figure 14—A unitized induction system capable of providing both CSFC and PSFC gear hardening.

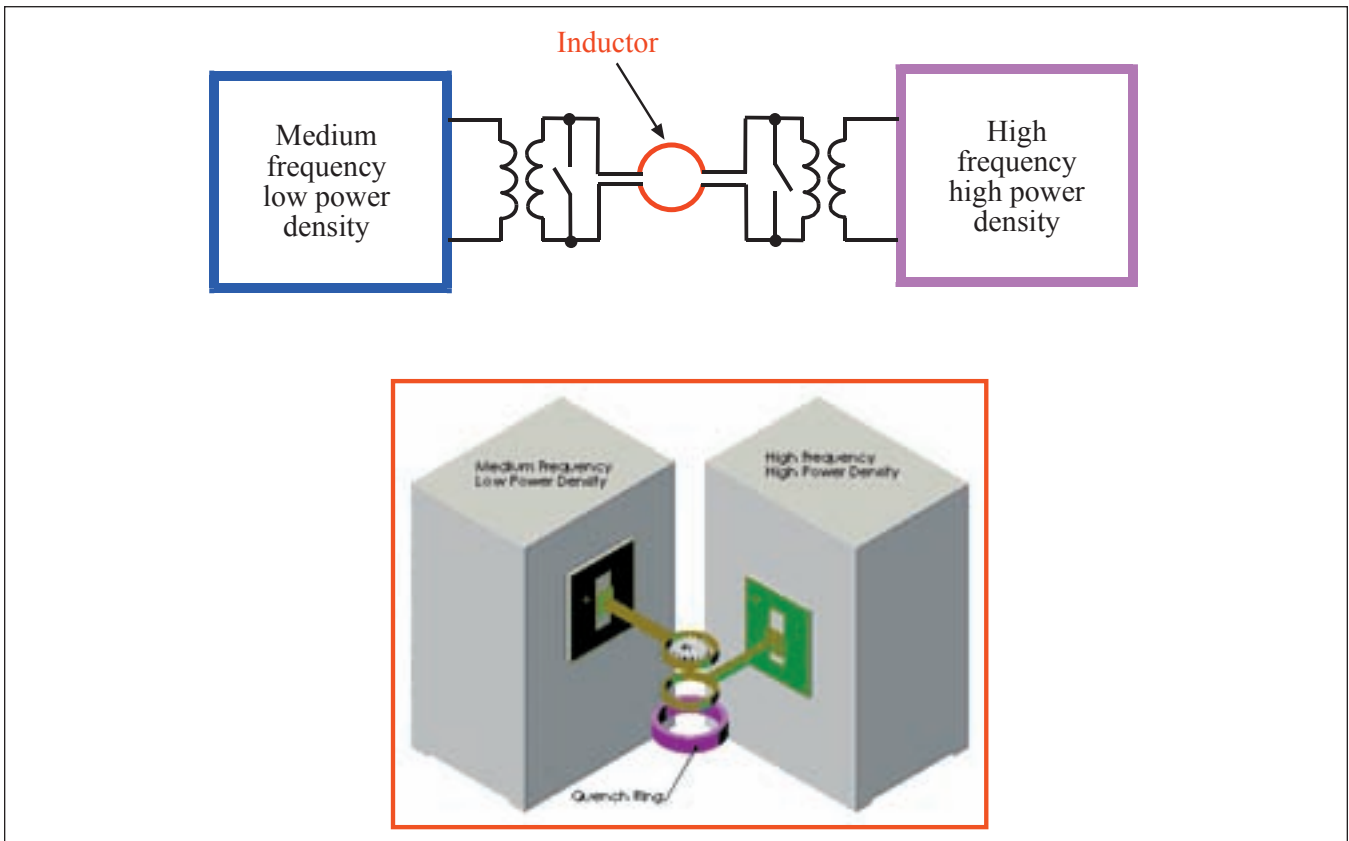

Figure 15—Dual frequency induction hardening utilizing a single inductor (top) vs. two inductors (bottom).

metallurgical result and decreasing the distortion in some cases. Preheat times are typically from several seconds to a minute, depending on the size and shape of the gear teeth. Obviously, preheating reduces the amount of energy required in the final heat and decreases thermal stresses as well.

After preheating, there might be a soak time ranging from two to 10 seconds to achieve a more uniform temperature distribution across the teeth of the gear. Depending upon application, preheat can consist of several stages (preheat pulses). Final heat times can range from less than one second to several seconds.

As a general rule, for both CSFC and PSFC techniques, the higher frequency is used for finer-pitch gears, which typically require a smaller case depth. Figure 14 shows a double sprocket, hardened utilizing a unitized induction hardening system capable of providing both CSFC and PSFC gear hardening.

*Pulsing dual-frequency concept (PDFC).* A third concept is the pulsing dual-frequency concept (PDFC). The idea of using two different frequencies to produce the desired contour pattern has been around since the late 1950s. This concept was primarily developed to obtain a contour hardening profile for helical and straight spur gears.

According to PDFC (Fig. 11c), the gear is preheated within an induction coil to a temperature determined by the process features. This temperature is usually 350°C–100°C below the critical temperature  $A_{c1}$ . Preheat temperature depends upon the type and size of the gear, tooth shape, prior microstructure, required hardness pattern, acceptable distortion and the available power source. The higher the preheat temperature, the lower the power required for the final heat. However, high preheat temperatures can also result in increased distortion.

As in previous concepts, PDFC can be accomplished using a single-shot mode or scanning mode. The scanning mode is applied for wider gears.

Typically, preheating is accomplished by using medium frequency (3–10 kHz). Depending on the type of gear, its size and material, a high frequency (30–450 kHz) and high power density are applied during the final heat stage. For the final heating stage, the selected frequency allows the current to penetrate only to the desired depth.

Depending upon the application, single-coil design or two-coil design arrangements can be used (Fig. 15).

Quenching completes the hardening process and brings the gear down to ambient temperature. In some cases, dual-frequency machines produce parts with lower distortion and have more favorable distribution of residual stresses compared to other techniques.

As mentioned above, when applying high frequency (i.e. 70 kHz and higher), it is important to pay special attention to gears with sharp corners. Due to the electromagnetic edge effect, high frequency has a tendency to overheat sharp edges and corners. This could result in weakened teeth due to decarburization, oxidation, grain growth and sometimes

continued



Figure 16—A contour hardened gear.

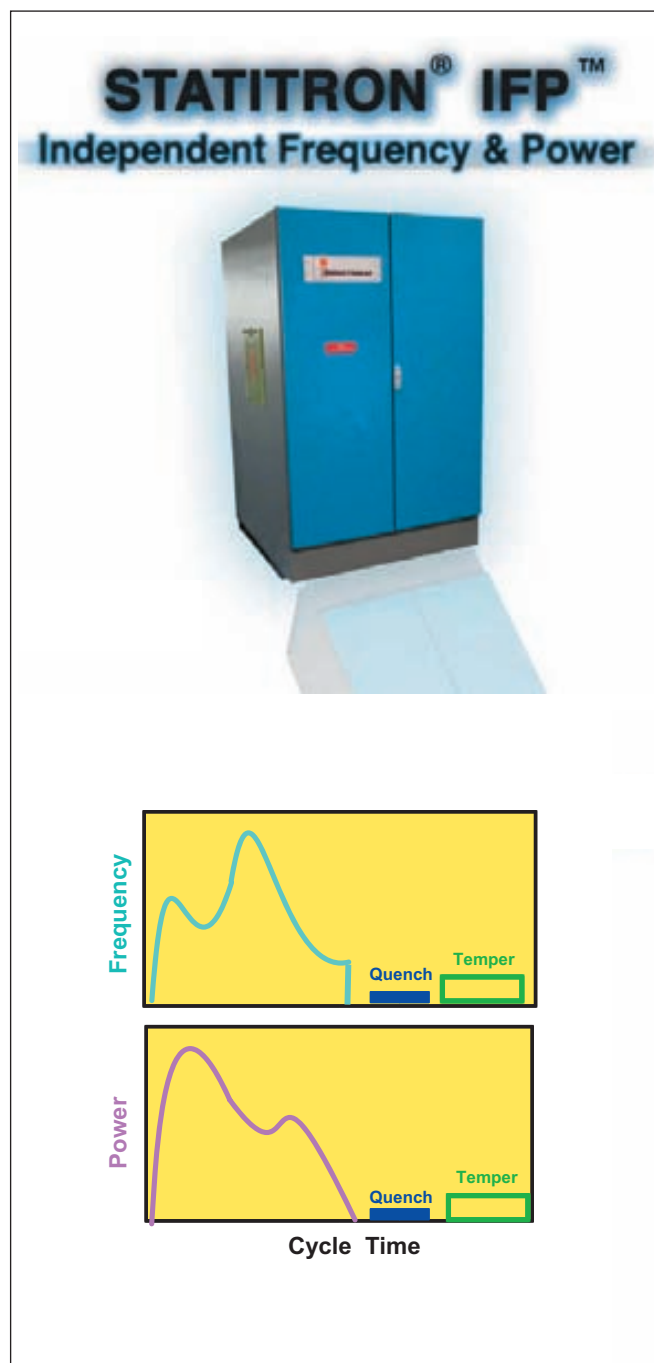

Figure 17—Independent frequency and power control.

grain boundary liquitation or even local melting of sharp edges. Therefore, in order to improve the life of a gear, the sharp edges and corners should be broken and generously chamfered. A four-inch spur gear induction contour hardened using the PDFC approach is shown on Figure 16. As one can see from Figure 16, the hardness pattern of an induction-hardened gear is quite similar to the hardness pattern obtained using carburizing. At the same time, the induction contour hardening process is accomplished in a much shorter time, with much simpler processing procedures using environmentally friendly processes.

**Simultaneous dual-frequency concept (SDFC).** The main drawback of the PDFC process is its relative complexity and high cost, since it is necessary to have two different power supplies and a fast lift-rotating devise. In some cases, it is possible to use a simultaneous dual-frequency concept (Figure 11d). This concept implies the use of a simultaneous dual-frequency power supply instead of two single-frequency inverters; however, the cost of these variable frequency devices is still quite high.

**Independent frequency and power concept (IFPC).** The ability to independently change the frequency and power of an induction heating system (Fig. 17, left) represents the long-awaited dream of commercial induction heat treaters, since that type of setup would provide the greatest process flexibility. This was the reason for the introduction of the STATITRON IFP (Independent Control of Frequency and

Power) inverter, which allows for independent change of frequency in a 5–40 kHz range and power in a range of 10–75 kW in a single-module system (Fig. 17, right) (Ref. 8). This concept (IFPC) substantially expands heat treat equipment capabilities for processing parts by programming power and/or frequency changes on the fly, maximizing heating efficiency while heating different part sizes and/or optimizing performances of both hardening and tempering while utilizing the same power supply more development is taking place to increase the power output of IFPC inverters.

**Computer Modeling**

Computer modeling is a major factor in the successful design of induction heating systems, providing the ability to predict how different factors and process parameters may influence transitional and final heat treating conditions (Refs. 1, 2). Modeling delineates what must be accomplished in the design of the system and/or process recipe to improve the effectiveness of the heat treatment and guarantee that the required results are obtained.

By its very nature, induction heating is characterized by a close relationship to the physical properties of the metal being heated (Ref. 1). Some physical properties strongly depend upon the temperature of the metal and its microstructure, while others are functions of magnetic field intensity and frequency as well. During the heating cycle, significant changes occur in such important physical properties as thermal conductivity,

continued

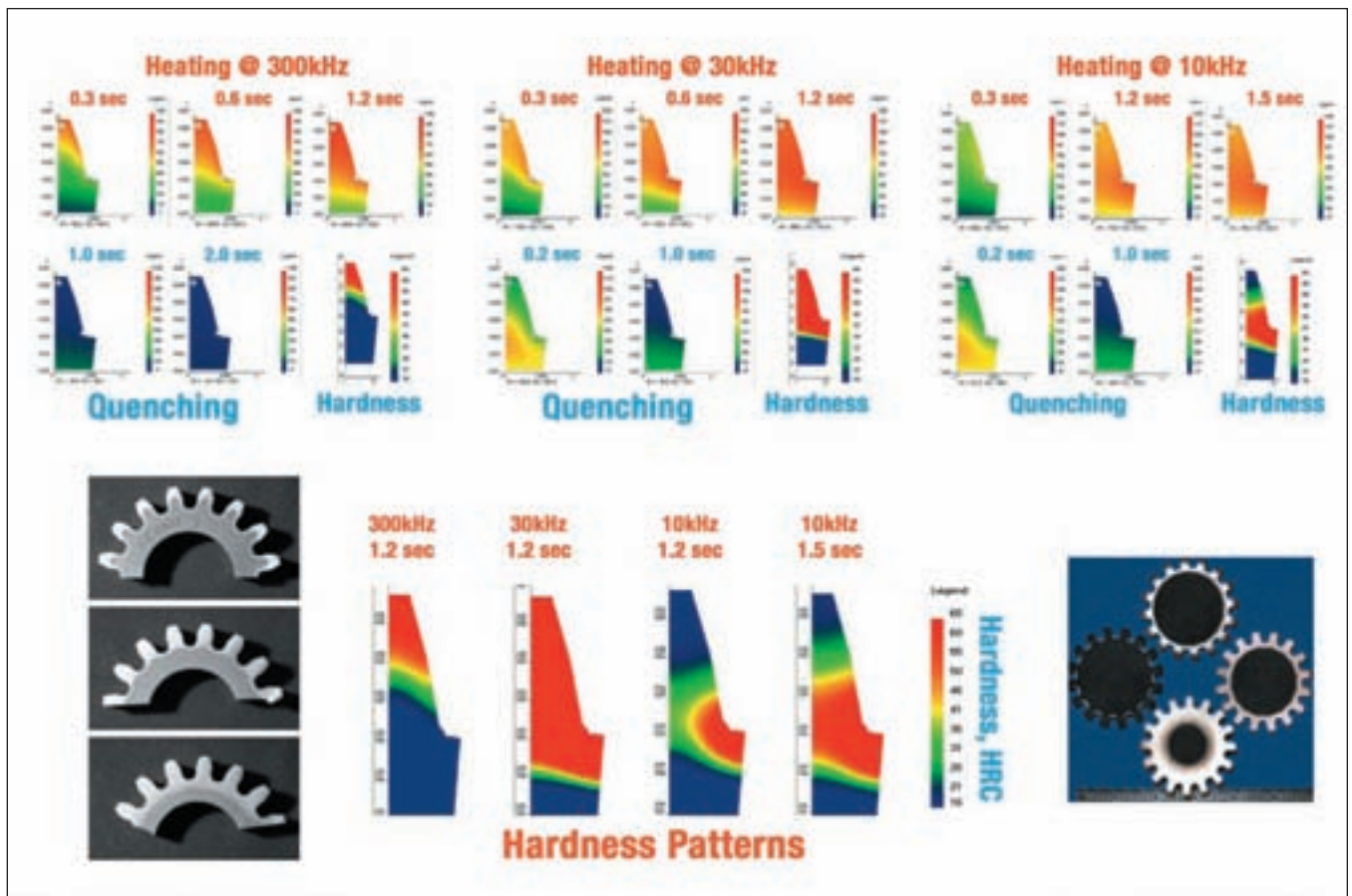

Figure 18—The effect of applied frequency on gear hardening pattern.

specific heat, magnetic permeability and electrical resistivity. Variations in magnetic permeability and electrical resistivity can result in an increase in the current penetration (heat source) depth of up to 16 times during the heating cycle from ambient to austenitization temperatures. Such a dramatic change leads to a considerable three-dimensional redistribution of the heat induced within the gear during the heating cycle (Ref. 1). This explains why variation in physical properties should be carefully taken into consideration when computer modeling an induction gear hardening process.

As an example, Figure 18 (top) shows the dynamics of temperature distribution during heating and quenching of a fine-pitch gear using different frequencies (300 kHz, 30 kHz and 10 kHz) (Ref. 2).

**High frequency.** As expected, when an RF frequency of 300 kHz is applied, an eddy current induced in the gear follows the contour of the gear (Fig. 10, left). Since the highest concentration of current density will be in the tip of the tooth, there will be a power surplus in the tip compared with the root (Fig. 18, top-left). Also taking into account that the tip of the tooth has the minimum amount of metal to be heated, compared with the root, the tip will experience the most intensive temperature rise during the heating cycle. In addition, from the thermal perspective, the amount of metal beneath the gear tooth root represents a much larger heat sink compared with that beneath the tooth tip.

Another factor that contributes to more intensive heating of the tooth tip is better electromagnetic coupling—the so-called proximity effect—between the inductor and tooth tip, vs. its root. Higher frequency has a tendency to make a proximity effect more pronounced (Ref. 1).

A combination of these factors provides rapid austenitization of the tooth tip, which, upon quenching, produces a martensitic layer on the tip.

**Low frequency.** When a low frequency, such as 10 kHz, is applied for heating fine-tooth gears, the eddy current flow and temperature distribution in the gear tooth will be quite different (Fig. 18, right).

A frequency reduction from 300 kHz to 10 kHz noticeably increases the eddy current penetration depth in the steel—from 1 mm to 5.4 mm—particularly at temperatures above the Curie temperature. In a fine-tooth gear, such an increase in penetration depth results in a current cancellation phenomenon in the tooth tip and pitch line area. This makes it much “easier” for induced current to take a “short” path, following the base circle or root line of the gear instead of the tooth profile (Fig. 10, right). The result is more intensive heating of the root fillet area compared with the tip of the tooth (Fig. 18, top-right), and the development there of martensite upon quenching.

**Hardening patterns.** An example of how the gear hardening pattern varies with applied frequency is shown in Figure 18 (bottom). The results of modeling support the experimentally obtained hardening patterns shown in Figure 9 and confirm the previous explanation of the physics of the electromagnetic-thermal processes that occur during induction

spin hardening of gears using different frequencies.

It is important to remember that the terms “high frequency” and “low frequency” are not absolute. For example, depending upon gear geometry, a frequency of 10 kHz might be considered low when heating fine-tooth gears, but would be considered as high frequency when hardening large gears having coarse teeth. Similarly, a frequency of 300 kHz could act as a very low frequency for certain gear tooth geometries, and be able to harden only the root of the tooth and unable to properly harden its tip.

## Conclusions

Induction hardening of gears includes a number of process concepts that can be applied depending on the part geometry and hardness profile required. Spin hardening techniques, wherein the coil encircles the part, are most often used for small and medium size gears. 

## References

1. Rudnev, V., D. Loveless, R. Cook and M. Black. *Handbook of Induction Heating*, Marcel Dekker Inc., New York, 2003.
2. Rudnev, V. “Spin Hardening of Gears Revisited,” *Heat Treating Progress*, ASM International, March/April, 2004, p. 17–20.
3. Rudnev, V., et al. “Induction Hardening of Gears: A Review, Part 1,” *Heat Treatment of Metals*, Wolfson Heat Treatment Centre, England, 2003.4, p. 97–103.
4. Rudnev, V., et al. “Induction Hardening of Gears: A Review, Part 2,” *Heat Treatment of Metals*, Wolfson Heat Treatment Centre, England, 2004.1, p. 11–15.
5. Davis, J.R. *Gear Materials, Properties, and Manufacture*, ASM International, 2005.
6. Parris, G. and D. Ingham. “The Submerged Induction Hardening of Gears,” *Gear Technology*, March/April, 2001, p. 28–40.
7. Rudnev, V. “Metallurgical Insights for Induction Heat Treaters, Part 3: Limitations of TTT and CCT Diagrams,” *Heat Treating Progress*, Nov./Dec., 2007, p. 23–25.
8. Doyon, G. “The Basics of Induction Heat Treating and Beyond,” Presentation at ASM International Conference, Sept.16–19, Detroit, 2007.
9. Rudnev, V. “Systematic Analysis of Induction Coil Failures, Part 8: Gap-by-Gap Gear Hardening Coils,” *Heat Treating Progress*, Nov./Dec., 2006, p. 19–20.
10. Rudnev, V. “Systematic Analysis of Induction Coil Failures, Part 5: Effect of Flux Concentrators on Coil Life,” *Heat Treating Progress*, March/April, 2006, p. 21–26.

**Dr. Valery Rudnev** is director of science and technology at Inductoheat. He is a Fellow of ASM International and received his M.S. degree in electrical engineering from Samara State Technical University and his Ph.D. in induction heating from St. Petersburg Electrical Engineering University, Russia. He has 28 years of experience in induction heating. His expertise is in materials science, metallurgy, electromagnetics, heat treating, computer modeling, and process development. Credits include 18 patents and 146 publications.