

## Basic Spur Gear Design

William L. Janninck  
Illinois Tools Division, ITW Inc.  
Lincolnwood, IL

Primitive gears were known and used well over 2,000 years ago, and gears have taken their place as one of the basic machine mechanisms; yet, our knowledge and understanding of gearing principles is by no means complete. We see the development of faster and more reliable gear quality assessment and new, more productive manufacture of gears in higher material hardness states. We have also seen improvement in gear applications and design, lubricants, coolants, finishes and noise and vibration control. All these advances push development in the direction of smaller, more compact applications, better material utilization and improved quietness, smoothness of operation and gear life. At the same time, we try

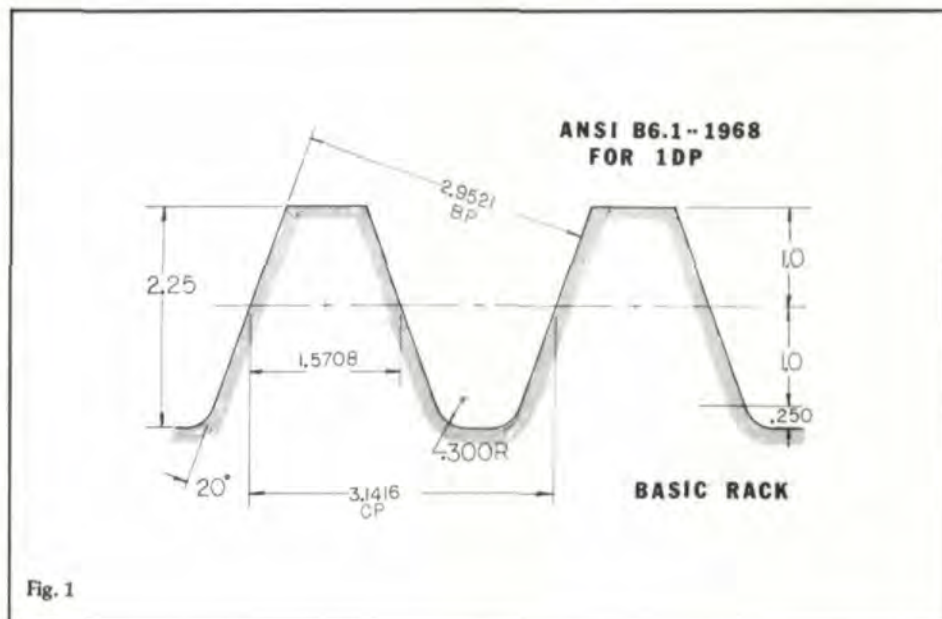

Fig. 1

### AUTHOR:

W. L. JANNINCK is a gear geometrician and consultant to the Illinois Tools Division of ITW Inc. He has experience in the design and application of both generating and forming type metal cutting tools, specializing in the area of tooling and gaging for the manufacture of gears, splines and sprockets. Prior to entering private practice, he was manager of product engineering and chief engineer at ITW. He has served on various committees of the AGMA and MCTI and is chairman of the AGMA Cutting Tool Committee. He also served on the SAE-ANSI Committee on Power Transmission Chains and Sprockets. He has written extensively on tool applications, gaging, gear design and gear inspection. He was educated at Northwestern University, Evanston, Illinois.

to improve manufacturing cost-effectiveness, making use of highly repetitive and efficient gear manufacturing methods.

All these considerations make for a bewildering number of parameters to work with. The novice or aspiring gear designer should not be overwhelmed by the many details involved, but gradually absorb as much basic gear related information as possible concerning any and all aspects of gearing. Eventually the overall picture of gear applications, design, qualification and manufacture will come into focus.

In discussing the basics of gear design we shall use an example of the simpler

geometrical case of spur or straight tooth parallel axis gears. Almost all of the basics are similar in other forms of gearing, such as helical and herringbone gears in a parallel axis arrangement and crossed axis helicals, bevel and worm gearing in the intersecting axes or skew axes arrangements. The details and geometry will vary, but the major concerns are quite similar.

### The Basic Rack

The basis for specifying gear teeth, the starting point for gear specification, is geometrical in nature and can be laid out in a diagram of the gear tooth form as if

the gear had an infinite number of teeth and were a rack. This concept is called the basic rack and differs for each tooth form system.

The current popular and widely used tooth form system for spur gears accepted worldwide is shown in Fig. 1. In the United States it is identified as the *ANSI B6.1 - 1968 Standard for Tooth Proportions for Coarse Pitch Involute Spur Gears*. Cutting tools to produce this tooth form in standardized diametral pitches are frequently carried in stock in gear cutting houses and tool supply firms.

The basic rack described here is far from the only one possible and in the archives, museums, text books and technical papers many others are found. At least 30 different basic forms of involute gears have been in popular use at some time. Forms by Brown & Sharpe, Grant, Sellers, Hunt, Logue, Willis, Day, Anderson, Parkinson, Nuttall, Fellows, Brown, Acme, Simmons, P&H, Wisdom, Maag, Sunderland and probably many more are sometimes still in use today, and the gear engineer should be aware of this gear lore. It is not unusual for a gear engineer to be asked to reproduce some of these old designs. While some of the tooth forms are now recognized as industry standards, many of the names of the originators have disappeared.

#### Noninvolute Tooth Forms

Noninvolute form conjugate gearing systems, such as the cycloidal form, can also be used for gear building. Modified involute systems like the 14.5° composite system are also sometimes used. Other noninvolute systems include Williams, Wildhaber, Novikov and Concurve. In the field of fine pitch gearing a number of noninvolute form systems are used regularly. Many are of the ogival form and follow the British Standard or the Black Forest Standard. Some names include Prescott, Circular Arc and Wickenburg. These sets may be found in the clock, watch, instrument, timer and small toy trade.

These basic rack systems are referred to only for background, and we will not deal with the quite interesting aspects of these types of gears. They each have their place in mechanisms and should be recognized

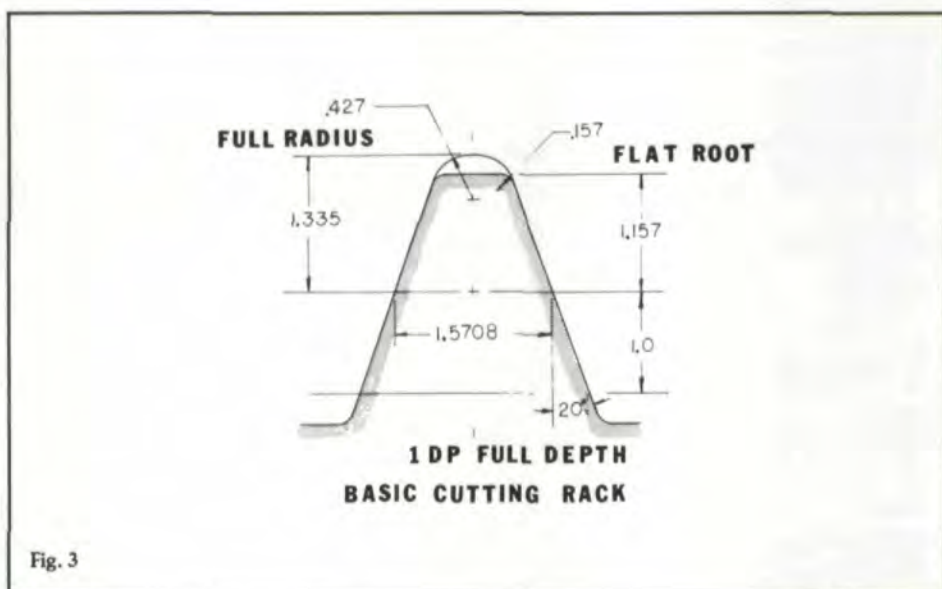
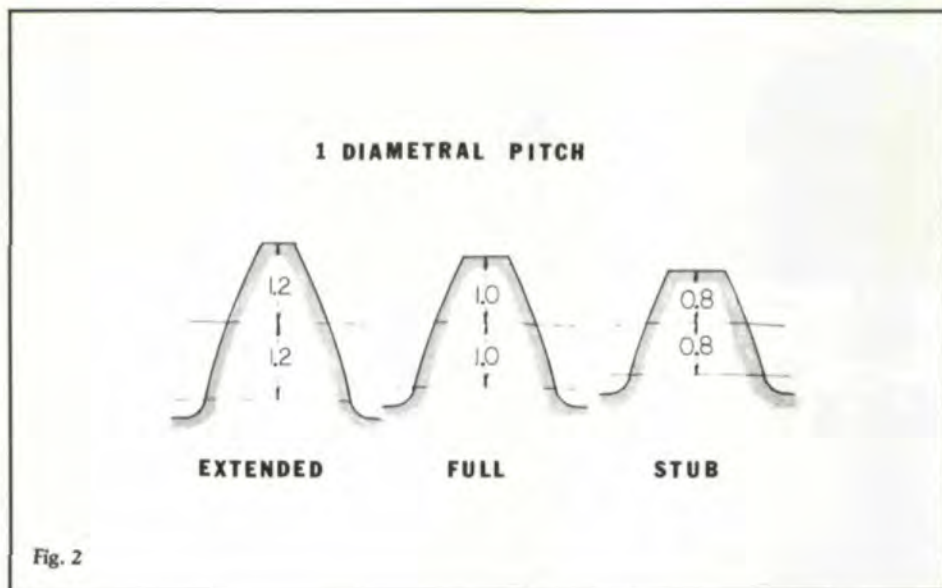

for that.

#### General Tooth Form Systems

In involute gearing there are three general tooth form systems. The three choices are full depth, stub depth and extended depth. (See Fig. 2.)

Full depth is probably the system of choice for most gear designers. It is specified using diametral pitch, an inch system. In this case, the addendum equals 1.0" for a 1 DP gear. The working depth equals 2", and clearance in the root area will vary as needed; in general, from a minimum of .157" to as much as .5".

Stub depth gears have been quite

popular for several reasons. The most important one is increased strength. Another is the possible use of smaller gear tooth numbers in compact transmission boxes. In a stub gear, the gear addendum is less than 1.0" and, likewise, the working depth is less than 2.0" for a 1 DP gear. Usually the gear addendum and working depth are about 75% to 80% of the full depth format.

Extended depth is not nearly so well known or so popular, but it does exist, and some very interesting gearsets have been made with it. The applications include printing roll drives, where the gear inaccuracy can be spread over as many as

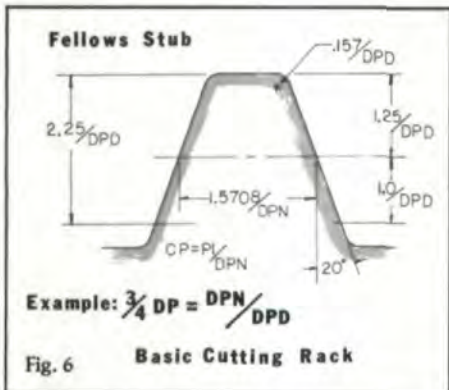
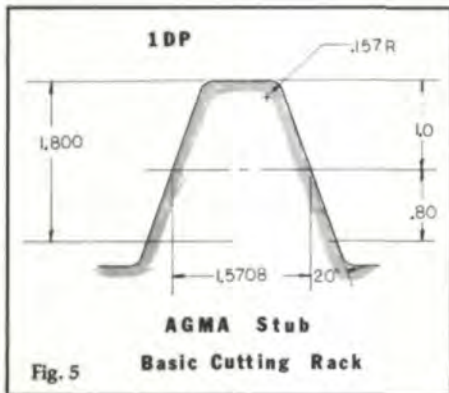
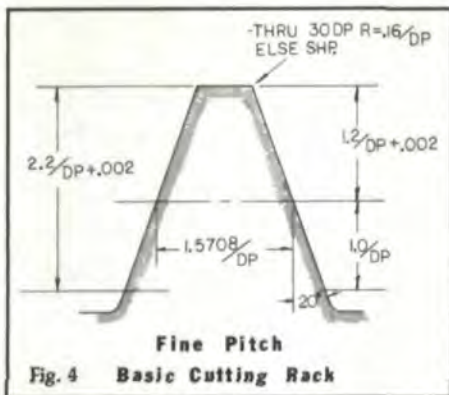

three tooth pairs and will smooth the rotational transfer of motion. In other gear boxes, the extra depth which usually brings along with it an increased contact ratio, possibly of two or more, and finer pitch teeth, has been referred to as a "quiet gear set". Extra depth teeth do have a property referred to as gear tooth compliance or flexure because of the height of the teeth. Excessively long depth will cause increased problems in the manufacturing area. Although no official standards are published, working depths of 2.2, 2.4, 2.5 and 2.7 for a 1 DP basis have been seen in use.

**FULL DEPTH SYSTEMS.** Some of the standards in use today which may not all be published or officially adopted by a standards group are shown in Table 1.

A finishing basic cutting rack is defined as the complement of the basic rack for purposes of describing the tooling used to produce the gear form. Fig. 3 shows the basic cutting rack for a full depth system, comparing the flat root to the full radius or full fillet form for 20 PA. Fig. 4 shows the basic cutting rack standardized for fine pitch gears, that is, 20 DP and finer. It shows the special considerations given to get an increasing amount of clearance in the gear root as the teeth get very small. The  $.20/DP + .002$  clearance is a larger proportionate amount at 100 DP than at 20 DP.

**STUB SYSTEMS.** The AGMA stub system shown in Fig. 5 has been very popular for many years for spur gears, particularly in industrial applications, and is also used as the standard tooth form for herringbone

gears. Another interesting system is shown in Fig. 6. It is the combination or split pitch system and uses the circular pitch and circular tooth thickness from one diametral pitch and the addendum and whole depth from another. On a gear of  $3/4$  DP, for example, the gear is basically a 3 DP gear with the shorter addendum and whole depth for a 4 DP gear; hence, it is a stub form. Some caution should be used with this system of stub specification.  $3/4$  DP has been mistaken for  $.75$  DP, which is substantially larger in size.

Extended depth systems, while widely used in certain areas of the gear industry, have never been adopted as an actual standardized tooth form. Extended depth systems are used in certain printing press applications and in some vehicle gearing.

Such systems might have the following specifications: PA, 20.0; Addendum, 1.2; Whole Depth, 2.65; Fillet Radius, .300.

**OTHER TOOTH SYSTEMS.** There are several ways to describe gears based on inch and metric measurements. For full depth we can specify the dimensions in four different ways.

1. **Diametral Pitch.** This is the ratio of gear teeth divided by the pitch diameter in inches. It is an inch system, and the dimensions for the gear data are calculated by dividing the specific basic rack values by the chosen diametral pitch. The diametral pitches are established in a list as recommended selection values.

2. **Circular Pitch.** The circular pitch of the gear is selected according to a recommended series, and the balance of dimensions is set in proportion to the chosen circular pitch by multiplying by the specific basic values. The proportions are the same as an equivalent diametral pitch gear, and then, if converted, the DP equals  $\pi$  divided by the circular pitch. There are applications where circular pitch spur gearing is still used today, and worm gear sets traditionally use the circular pitch to set the tooth proportions.

3. **Inch Module.** In the modular specification of gears, the module number is the addendum of the gear desired. A 1" module gear has a 1" addendum and, thus, is equivalent to a 1 diametral pitch gear. While modular inch gears are used occasionally, a series of recommended modules has not been published.

4. **Metric Module.** In the metric

Table 1 — Full Depth Systems

Name	PA	Addendum	Whole D.	Fillet R.
Flat Root	14.5	1.0	2.157	.157
Flat Root	20.0	1.0	2.157	.157
ANSI B6.1	20.0	1.0	2.250	.300
Full Fillet	14.5	1.0	2.440	.534
Full Fillet	20.0	1.0	2.335	.427
Full Fillet	25.0	1.0	2.250	.317
Fine Pitch	20.0	1.0	2.2 + .002	Var.

Table 2 — Stub Systems

Name	PA	Addendum	Whole D.	Fillet R.
AGMA Stub	20.0	0.80	1.80	.157
Full Fillet	20.0	0.80	2.0	.500
Fellows Stub	14.5	1/DPd	2.25/DPd	.157/DPd
Fellows Stub	20.0	1/DPd	2.25/DPd	.157/DPd
DPn = DP Numerator		DPd = DP Denominator	Cir. Pitch = $\pi/DPn$	

module the addendum of the gear is specified in millimeters, and all other dimensions are likewise set in proportion to the addendum. It is a metric based system and a recommended series of modules are published. For a simple conversion, one can divide 25.4 by the metric module and arrive at the equivalent diametral pitch, and work from there if one is more comfortable with the DP system.

Fig. 7 shows a comparison of the four bases with relative sized gear teeth.

**Symmetrical Rack Systems.** The standard proportioned gear or "textbook" design is based on a symmetrical rack concept; that is, both gears in a set can be specified from a common rack system. From a practical standpoint, this permits the use of a single generating tool, hob or shaper cutter to produce a wide variety of mating gear sets. (See Fig. 8.)

**Unsymmetrical Rack Systems.** Most gear designs encountered today are based on the symmetrical system. In some instances asymmetry has been used. One example is obvious where the same strength material is used for both gear members and where the pinion is somewhat smaller than the gear. The beam strength of the gear is greater than that of the pinion. One way to bring the strength of both gears into balance is to increase the tooth thickness of the pinion and reduce that on the gear by an equal amount, keeping diameters and center distance unchanged. Special cutting tools are required for both the gear and the pinion. Fig. 8A illustrates an unsymmetrical rack application.

#### Natural Undercutting

As the number of teeth in a standard proportioned gear decreases, a point is reached where the phenomenon of natural undercutting occurs. For the standard 20 PA, full depth system, 2.25 WD and .300 fillet radius, this point occurs at 16 teeth and lower. The definition of natural undercut is the trimming away of a portion of the involute profile just above the gear base diameter by the rolling generating action of the cutting rack. The lower the number of the teeth being cut, the more the undercutting, until at nine teeth, insufficient involute is left to permit proper functioning of the teeth. In other words, the contact ratio is less than 1.0. Fig. 9 shows a chart comparing the

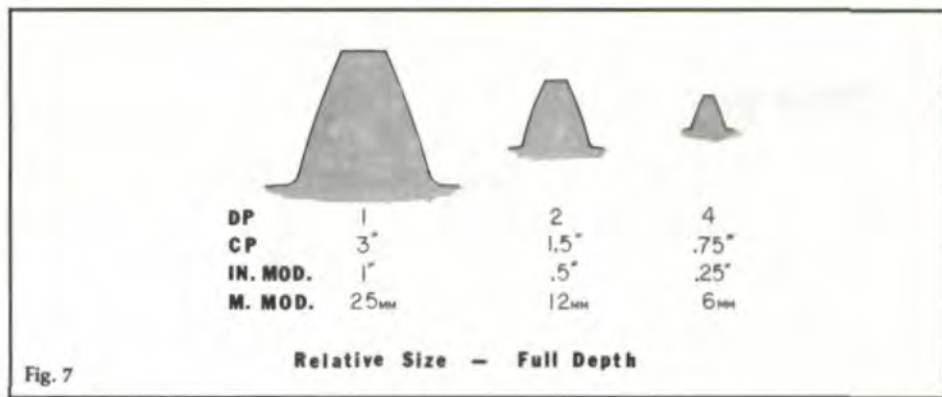

Fig. 7

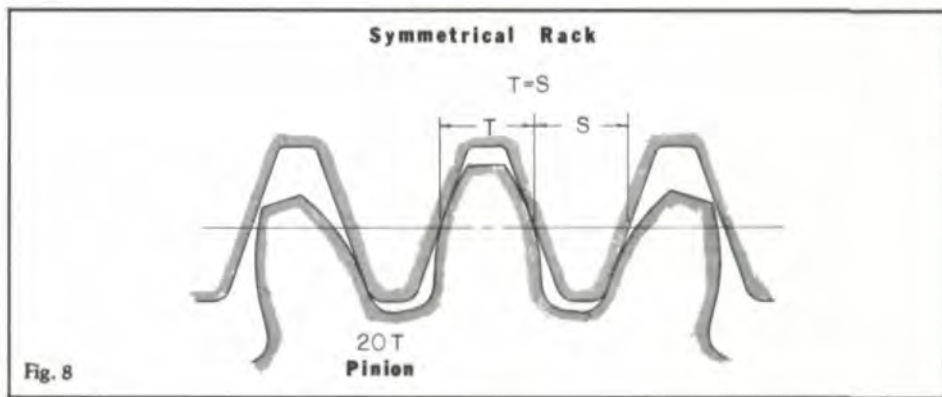

Fig. 8

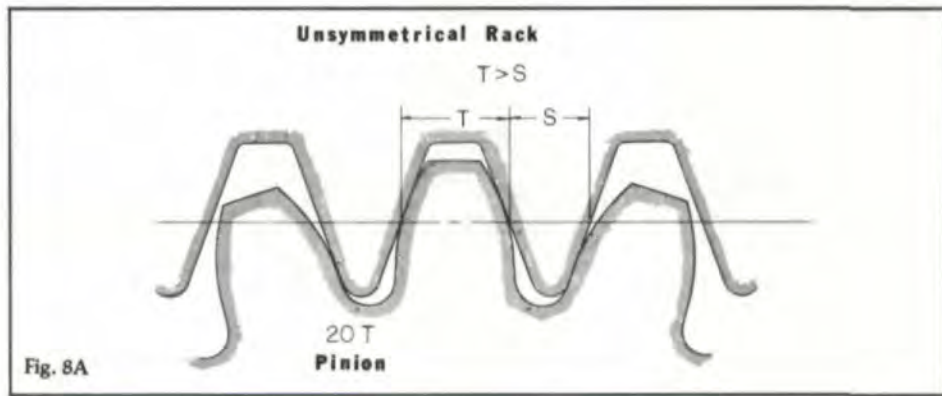

Fig. 8A

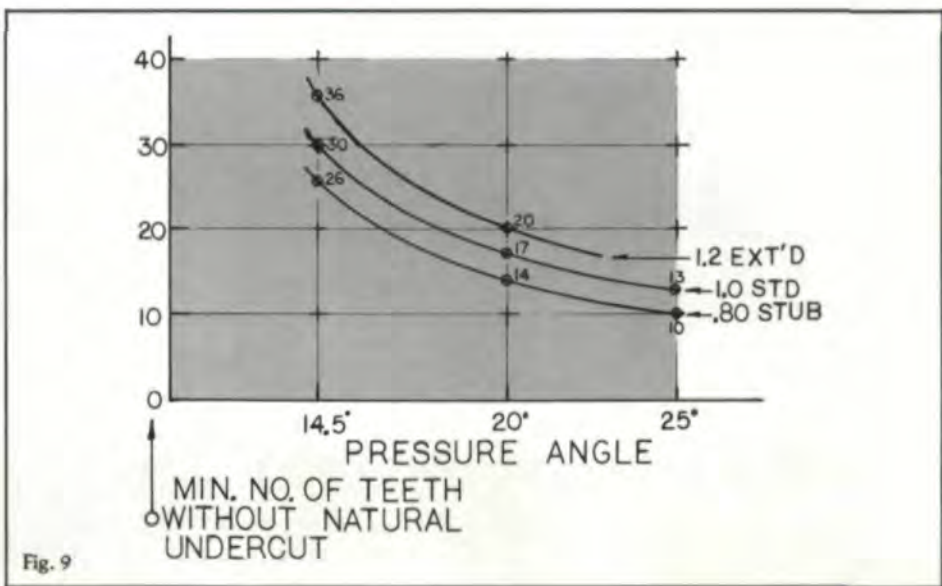
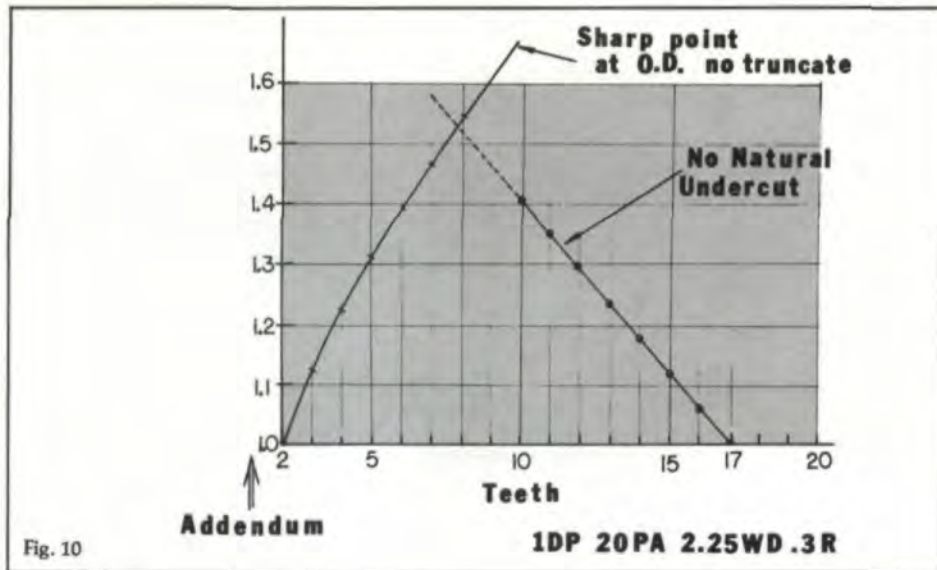

Fig. 9



number of teeth at which undercutting begins for various pressure angles and for .8 stub, 1.0 full depth and 1.2 extended depth.

#### Eliminating Natural Undercutting

Undercutting not only removes part of the involute but also reduces the strength of the pinion by thinning the base of the tooth. The use of enlarged, oversize or long addendum pinions is a way of reducing or eliminating the natural undercut. This is accomplished by holding the cutting rack out on the pinion, creating a long addendum and an increased tooth thickness, and then sinking the cutting rack in on the gear, creating a short addendum and a reduced tooth thickness. This approach holds the center distance at standard. An alternative to this approach is to enlarge the pinion and hold the gear at standard. Spread centers or non-standard centers are required for this set, and whenever the centers are non-standard, there is a change in the operating pressure angle, departing from the nominal gear set value. For external gears the operating pressure angle rises if the centers are spread and drops if the centers are closed.

Fig. 10 is a chart of the enlargement necessary to eliminate natural undercut.

#### Sharp Pointed Teeth

As the pinion is enlarged on diameter or the pinion cutting rack is shifted out, the tip flat at the outside diameter is reduced. If shifted far enough, the gear tip will eventually become sharp pointed and then, beyond that point, the gear outside diameter will be reduced or truncated, and the gear will have depth values below standard. The relationship of oversize addendum relative to achieving a sharp pointed pinion at the standard

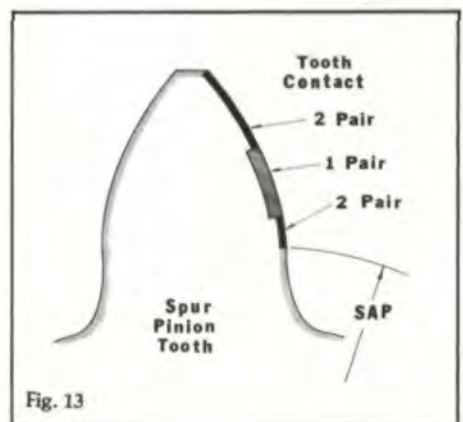
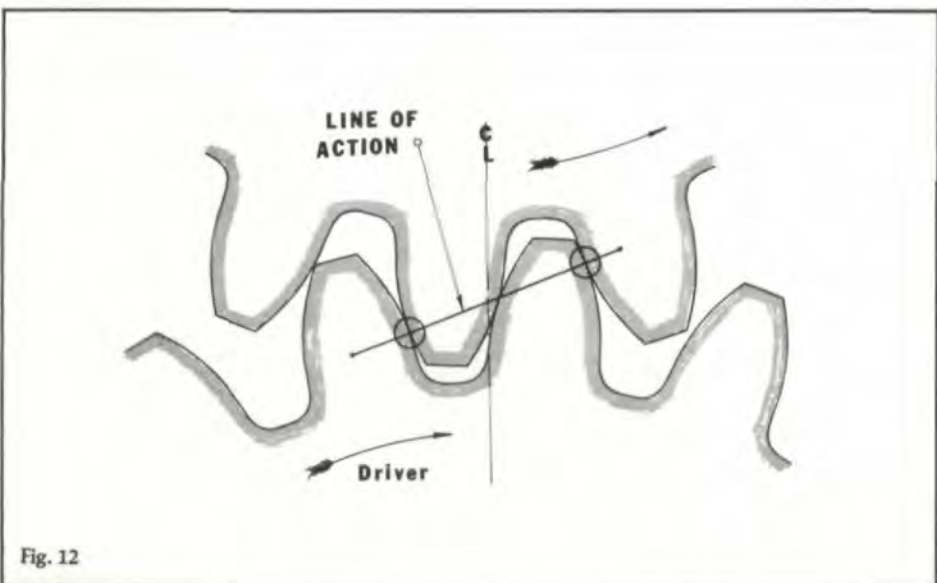
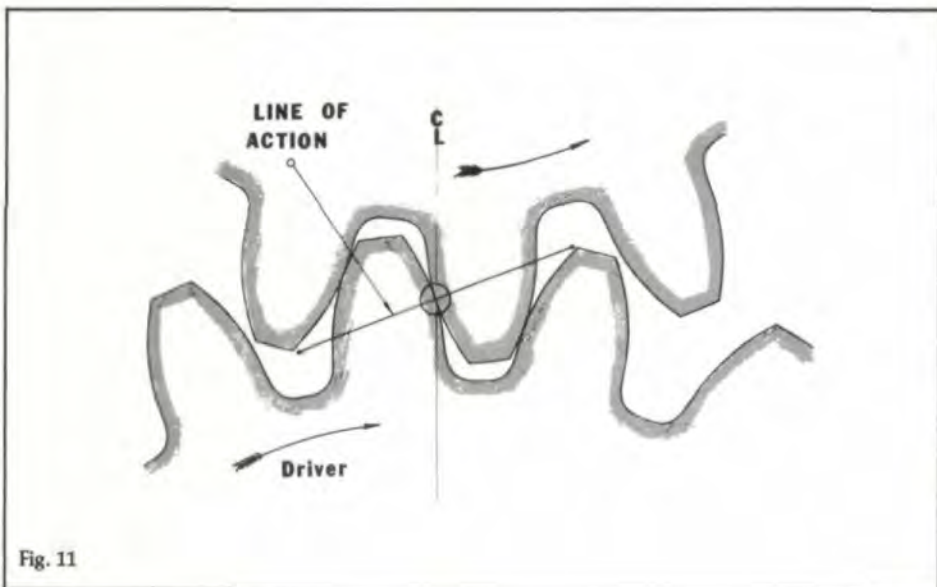

whole depth without truncation is also shown in Fig. 10. A compromise may have to be made in some cases between undercutting and sharp pointed teeth if electing to work with small numbers of pinion teeth.

### Contact Ratio

Contact ratio, which is the actual line of action divided by the base pitch, is a measure of the tolerance for passing the load supporting contact from the current pair of gear teeth to another succeeding pair. A contact ratio equal to 1.0 means a new pair of teeth pick up the contact transfer immediately after the old teeth separate from contacts with little back-up or insurance for the exchange.

A contact ratio below 1.0 means there is not enough involute surface available to make a timely exchange with proper angular rotation and, aside from inertial carry over, damaging edge contact can occur which is usually associated with gear noise.

A contact ratio greater than 1.0, such as 1.5, signifies that, for a substantial part of the time two pairs of gear teeth carry the load, and the balance of time only one pair of teeth carry the load. Fig. 11 illustrates the instant in time when there is only one pair of gear teeth in contact, and Fig. 12 shows another instant when two pair of teeth are in contact and supporting the load on a gear set with 1.556 contact ratio. Fig. 13 shows the progression of teeth pairs in contact across the active gear profile.

### Gear Noise

Gear noise is frequently associated with the contact ratio and total tooth depth, the stub teeth being more prone to noise and at the same time relatively

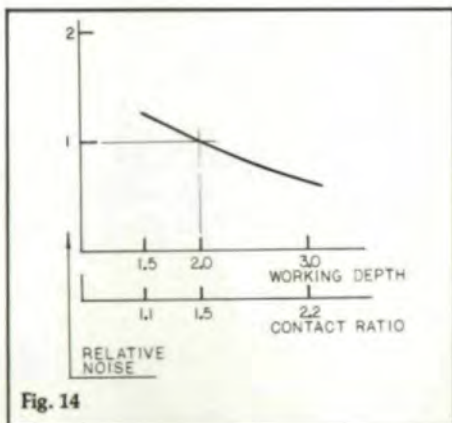

Fig. 14

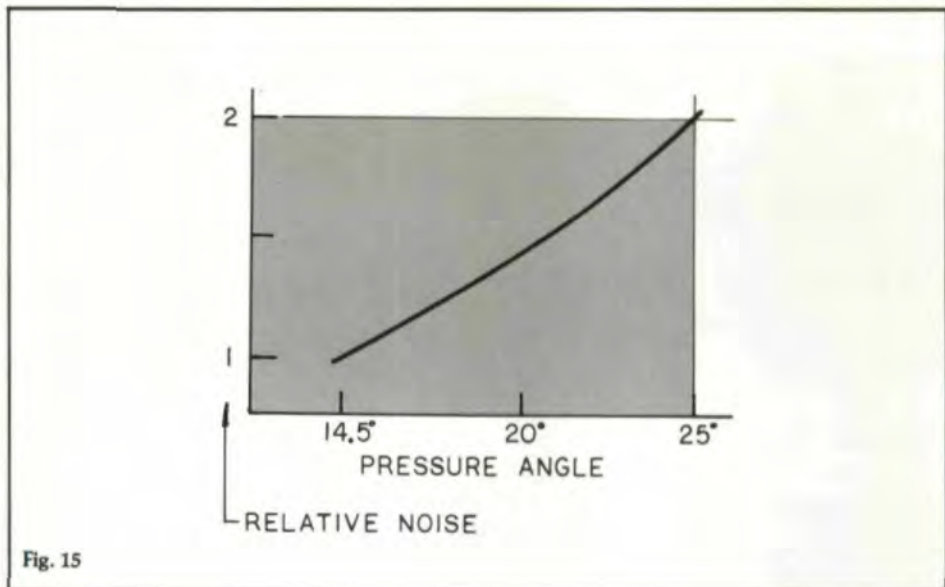

Fig. 15

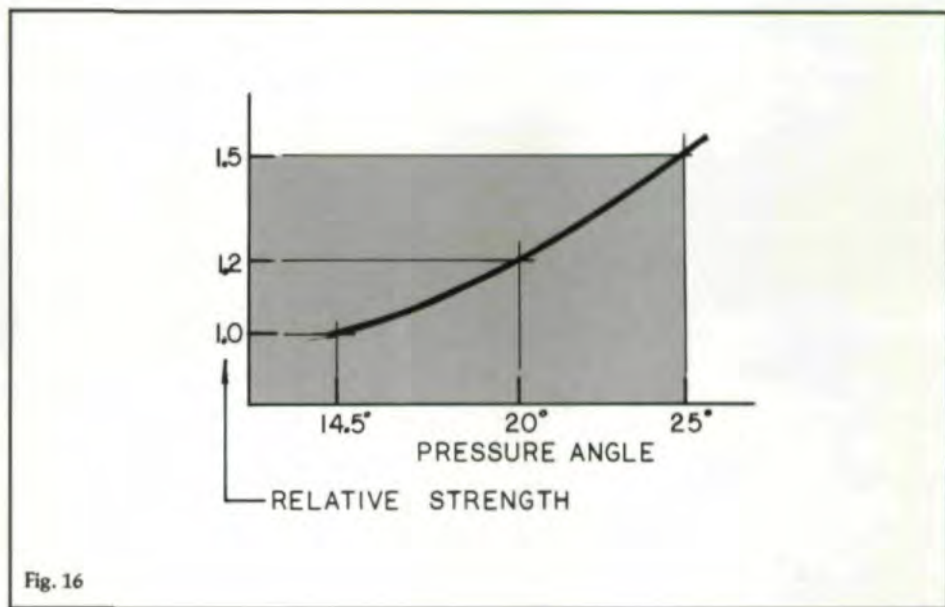

Fig. 16

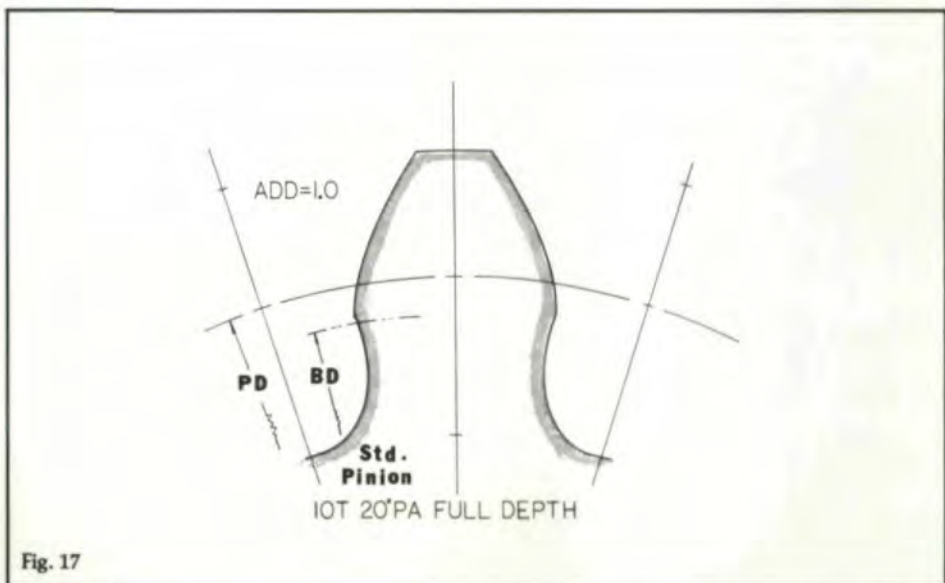

Fig. 17

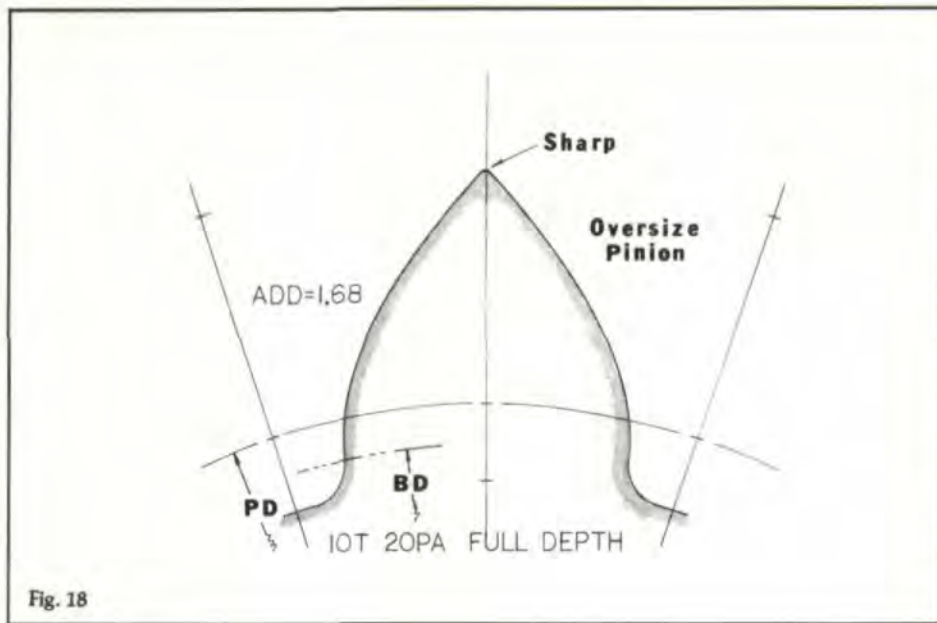

Fig. 18

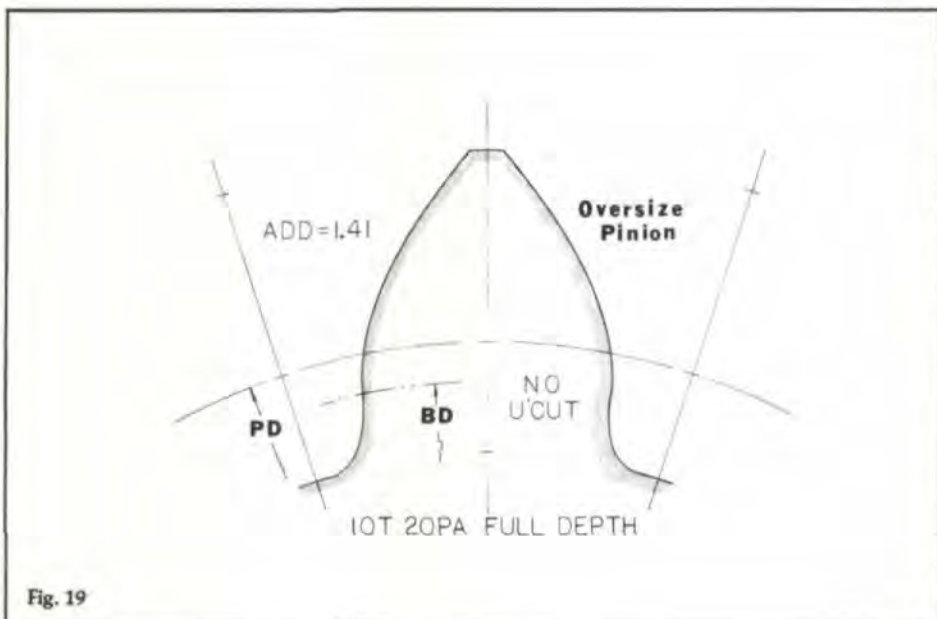

Fig. 19

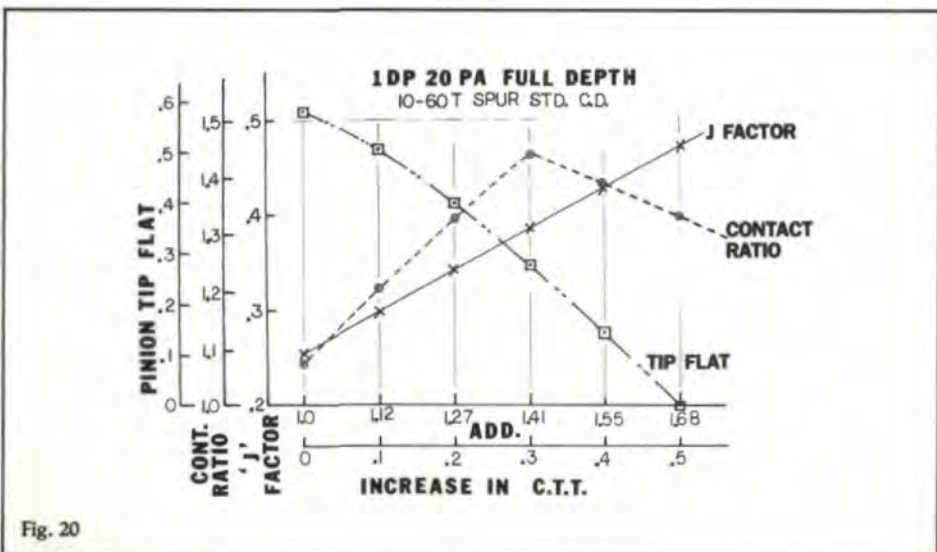

Fig. 20

lower on contact ratio. Extended depth teeth with higher contact ratios tend to be quieter. The graph in Fig. 14 illustrates this relationship.

Gears with lower pressure angles are also known to have lower noise levels and, because of their geometry, have higher contact ratios as graphically shown in Fig. 15.

#### Relative Strength

As the pressure angle goes up, the gear tooth bending strength goes up also, other things being equal. Likewise, as the pressure angle is reduced the strength is lessened. The relationship of the pressure angle and relative strength is shown in Fig. 16.

#### A Case Study

To focus on some of the generalities addressed, a sample spur gear set was constructed having a pinion of 10 teeth mating with a 60 tooth gear. If the standard 20 PA full depth 2.25 WD and a .300 fillet radius are used, a natural undercutting situation will occur. Fig. 17 is a scale form of the pinion generated with standard proportions using the above rack form. The addendum is 1.0 and the undercutting is visible just above the base circle.

In Fig. 18 the basic rack has been held out and the outside diameter of the pinion enlarged, creating an oversize pinion. The amount of oversize used is that necessary to reach a sharp pointed tip, but still retain the standard full depth without truncation. All signs of natural undercutting are gone. The addendum is 1.68.

Another approach was to make the pinion just enough oversize to eliminate the natural undercut, which only required an addendum of 1.41, a value readily found in the trade standards. Fig. 19 shows the form for the final design.

An interesting analysis of this gear set can be made by plotting pinion tip flat, contact ratio and "J" factor against the pinion addendum. This is presented in Fig. 20, a three variable graph. The tip flat is largest at standard addendum and decreases to zero at 1.68 addendum. At the same time, the "J" factor, which is a measure of strength, is increasing steadily. An interesting thing occurs with the contact ratio. It climbs as the pinion addendum increases, until at 1.41 addendum the contact ratio begins to decline.

The use of the 1.41 addendum represents a good compromise for all three variables.

### Relative Sliding

As a pinion tooth passes through the mesh contact zone with its mating gear, the tooth surfaces pass over each other. Except for the point at the operating pitch circles where pure rolling exists, different lengths of involute surface on each mating gear sweep over each other and sliding occurs. This sliding is usually greatest near the pinion outside diameter, reduces to zero at the operating pitch diameter and reverses direction and continues to increase again to a maximum near the start of active profile. Of the standard proportioned gears, stub teeth have the least sliding and those using the extended depth have the most. Likewise long addendum gears have more sliding than standard addendum gears. In rating gears for durability, relative sliding is a factor and must be considered. Fig. 21 graphically illustrates, for our case study gear sets of 10 & 60 teeth, the comparison of involute segments at the tip of the pinion

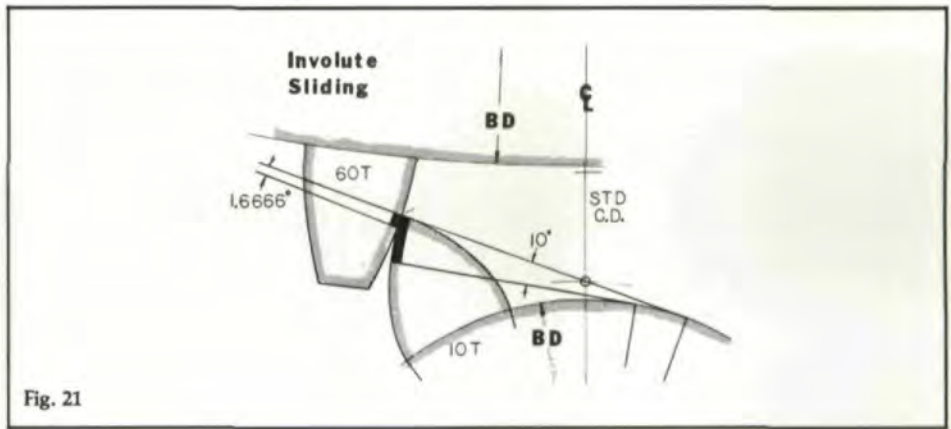

Fig. 21

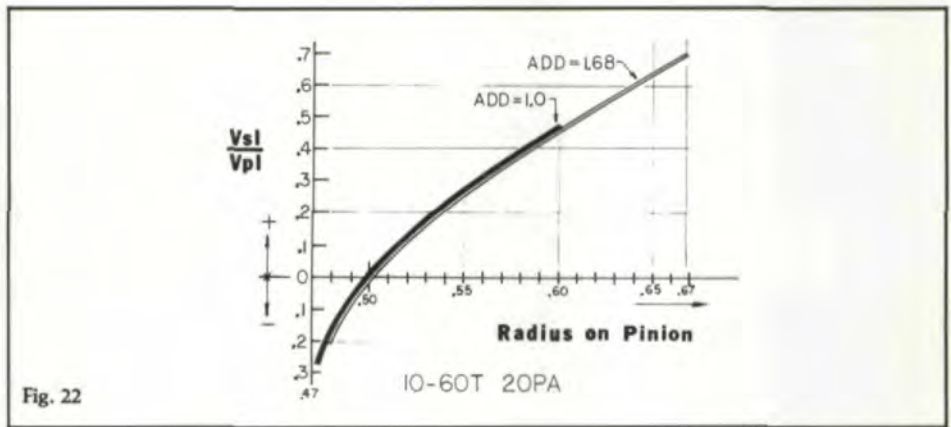

Fig. 22

(continued on page 48)

## Gear Analysis Software What took days ... Now takes minutes

### Benefits

- Save design time up to 80%
- Save manufacturing cost up to 40%
- Reduce noise
- Increase life
- Reduce weight
- Optimum design
- and more ...

Just a few of our valued customers

- General Motors • General Electric
- Lockheed • Arrow Gear
- Overton Gear

Plus over 60,000 customers using our TK Solver problem solving software.

Over 60 programs to choose from.

Priced from \$25 to \$10,000.

Buy the software you really need, no more.

In most of the programs the formulas are right in front of you. Change them if you like.

Practical Software from an established company

# UTS

Universal Technical Systems, Inc.  
1220 Rock Street, Rockford, IL 61101, USA

Call us toll free to get more information about the UTS family of software products or to know more about our hands on training schools on solving practical problems.

(800) 435-7887 Toll free. (815) 963-2220 In Illinois  
(815) 963-8884 FAX



## BACK TO BASICS . . .

(continued from page 43)

and flank of the gear that must pass over each other.

Fig. 22 is a plot of the ratio of the sliding velocity and the rotational velocity at various radii on the pinion for a standard addendum and a 1.68 long addendum. The oversize has a significant effect on the pinion tip with the involute sliding approaching 70% of the pitch line velocity for the long addendum design.

### Very Small Pinions

Seeing just how small a number of teeth can be designed into the pinion of a gear set is not only a challenge, but also a practical exercise. Reduced numbers of gear pairs can reduce the number of components needed as well as cost and space requirements. In the case of a reversing drive, a one-pair set can reduce the cumulative effect of total backlash. However, other matters involved require careful consideration before using such small pinions. Gear manufacturers will warn of the difficulties in producing such parts with useable profiles, especially in the region near the base circle.

Earle Buckingham found a design for a five tooth spur gear set, but concluded that a 22.5° pressure angle was required.<sup>(1)</sup> He found a symmetrical rack form would work and described the design in one of his books. This pinion is shown in Fig. 23. It has a contact ratio of 1.06 available.

Spur pinions of four teeth have also been made. One such example is presented in Fig. 24. This design uses and requires an unsymmetrical basic rack, implying a separate generating tool for the pinion and the gear. It is geometrically impossible to develop any spur pinions with sufficient involute form to get a contact ratio equal to 1.0 with fewer than four teeth.

If helical gears are considered, it is possible to make and use pinions of one, two and three teeth, and a sketch is given in Fig. 25 of a one-tooth helical pinion to show the possibilities.

### References

1. BUCKINGHAM, EARLE. *Spur Gear Design, Operation and Production*. 1st ed. New York: McGraw-Hill, 1928. p. 194.

**Acknowledgement:** Presented at SME Gear Processing and Manufacturing Clinic, 1987. Reprinted courtesy of Society of Manufacturing Engineers.

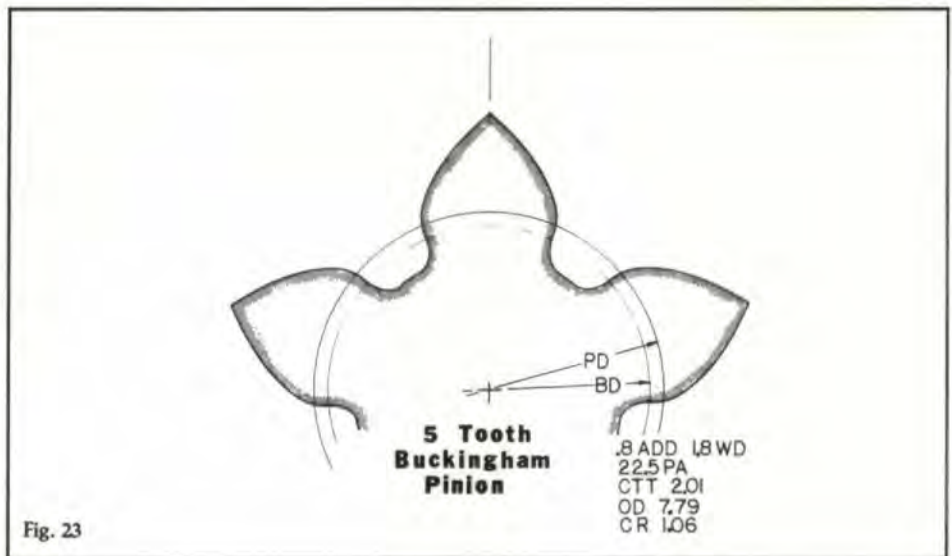

Fig. 23

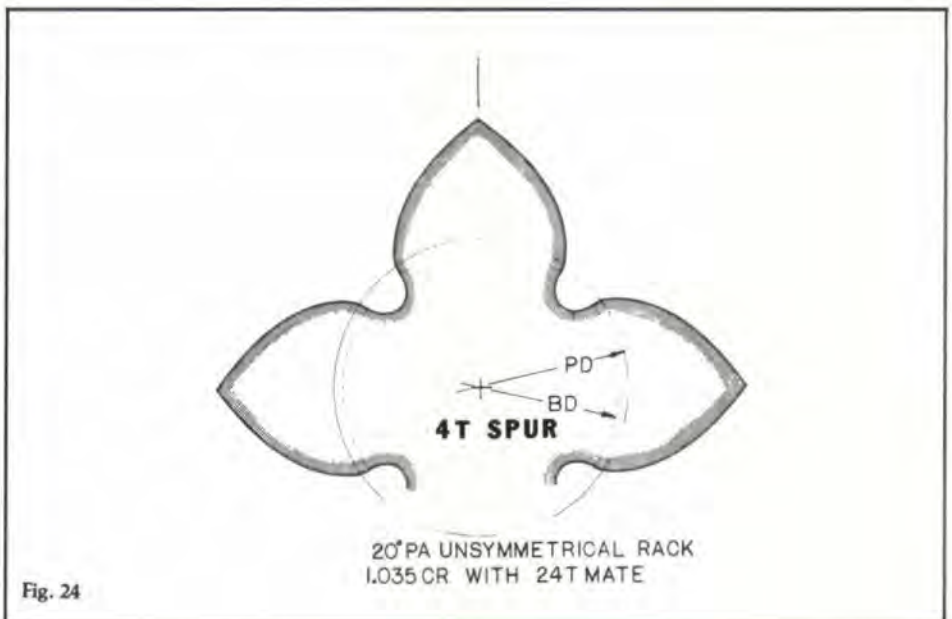

Fig. 24

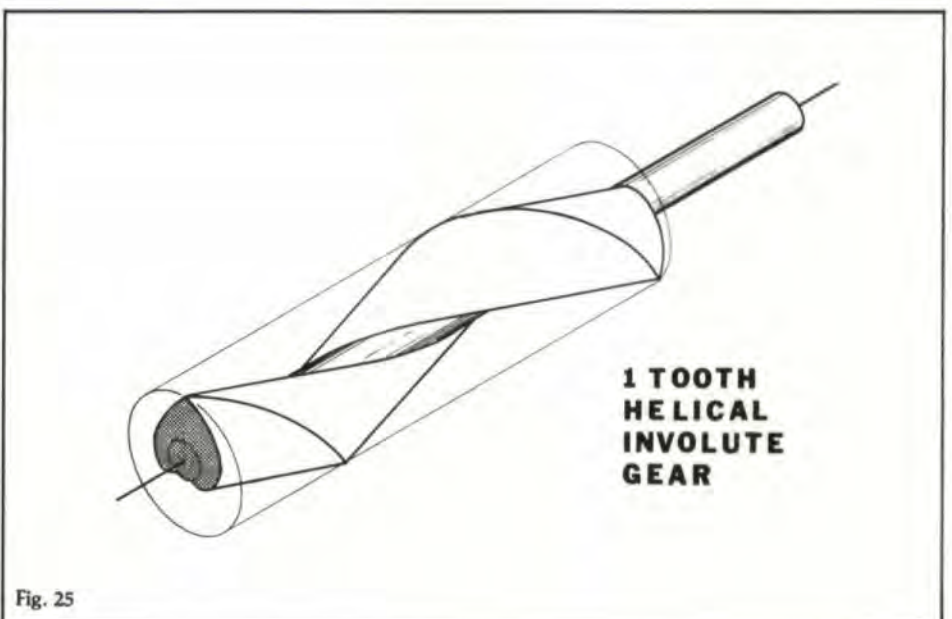

Fig. 25